

# INDEX

型番	品名	ページ
2SF	3Sエンドミル2枚刃(標準刃) <i>2-Flute Standard End Mills</i>	1 ~ 6
2LF 2XLF	3Sエンドミル2枚刃(ロング刃・特ロング刃) <i>2-Flute Long &amp; Extra Long End Mills</i>	7 ~ 15
LS-2LF	ロングシャンクエンドミル2枚刃 <i>2-Flute Long Shank End Mills</i>	16
XLS-2SF	特ロングシャンクエンドミル2枚刃 <i>2-Flute Extra Long Shank End Mills</i>	17
V-2SF	Vコート 3Sエンドミル2枚刃 <i>2-Flute V-coat Standard End Mills</i>	18 ~ 20
4SF	3Sエンドミル4枚刃(標準刃) <i>4-Flute Standard End Mills</i>	21 ~ 24
6SF	3Sエンドミル6枚刃(標準刃) <i>6-Flute Standard End Mills</i>	25
4LF 4XLF	3Sエンドミル4枚刃(ロング刃・特ロング刃) <i>4-Flute Long &amp; Extra Long End Mills</i>	26 ~ 31
6XLF	3Sエンドミル6枚刃(特ロング刃) <i>6-Flute Extra Long Flute End Mills</i>	32
LS-4LF	ロングシャンクエンドミル4枚刃 <i>4-Flute Long Shank End Mills</i>	32
XLS-4SF	特ロングシャンクエンドミル4枚刃 <i>4-Flute Extra Long Shank End Mills</i>	33
2BE	ボールエンドミル2枚刃 <i>2-Flute Ball End Mills</i>	34 ~ 37
4BE	ボールエンドミル4枚刃 <i>4-Flute Ball End Mills</i>	38
2LS-BE	ロングシャンクボールエンドミル2枚刃 <i>2-Flute Long Shank Ball End Mills</i>	39
4LS-BE	ロングシャンクボールエンドミル4枚刃 <i>4-Flute Long Shank Ball End Mills</i>	39
XLS-BE	特ロングシャンクボールエンドミル2枚刃 <i>2-Flute Extra Long Shank Ball End Mills</i>	40
LF-BE	ロング刃ボールエンドミル2枚刃 <i>2-Flute Long Flute Ball End Mills</i>	40
NBE	テーパードネックボールエンドミル <i>Tapered Neck Ball End Mills</i>	40
2RBE	ラジラスエンドミル2枚刃 <i>2-Flute Radius Ball End Mills</i>	41 ~ 43
4RBE	ラジラスエンドミル4枚刃 <i>4-Flute Radius Ball End Mills</i>	44 ~ 45
CRE	コーナーラウンディングエンドミル <i>Corner Rounding End Mills</i>	46
CM	センター面取りミル <i>Center Chamfering End Mills (Standard)</i>	47
CMU	センター面取りミル「UF処理付(浸透拡散処理)」 <i>Center Chamfering End Mills (Ultra F. Stain Less Use)</i>	47
2TE	テーパードエンドミル2枚刃 <i>2-Flute Tapered End Mills</i>	48 ~ 49
4TE	テーパードエンドミル4枚刃 <i>4-Flute Tapered End Mills</i>	50 ~ 51
2TES	テーパードエンドミル2枚刃(ショート刃) <i>2-Flute Tapered End Mills(Short Flute)</i>	52
4TES	テーパードエンドミル4枚刃(ショート刃) <i>4-Flute Tapered End Mills (Short Flute)</i>	52
RB2TE	テーパードラジラスエンドミル2枚刃 <i>2-Flute Tapered Radius Ball End Mills</i>	53
KE-OH	キー溝用エンドミル(プラス公差) <i>Key Way End Mills, Straight Shank (Over High Tolerance)</i>	54
KE-OH-BS5	キー溝用エンドミル・BSシャンク(プラス公差) <i>Key Way End Mills, BS5 Shank (Over High Tolerance)</i>	54
KE-OL	キー溝用エンドミル(マイナス公差) <i>Key Way End Mills, Straight Shank (Over Low Tolerance)</i>	55
KE-OL-BS5	キー溝用エンドミル・BSシャンク(マイナス公差) <i>Key Way End Mills, BS5 Shank (Over Low Tolerance)</i>	55

# INDEX

型番	品名	ページ	
2S-T	引きネジ付3Sエンドミル2枚刃(テーパージャック)	2-Flute End Mills (Drawing Thread Taper Shank)	56
4S-T	引きネジ付3Sエンドミル4枚刃(テーパージャック)	4-Flute End Mills (Drawing Thread Taper Shank)	56
2SL-T	引きネジ付ロングハイヘリエンドミル2枚刃(テーパージャック)	2-Flute Hi-Helical Long Flute End Mills (Drawing Thread Taper Shank)	57
4SL-T	引きネジ付ロングハイヘリエンドミル4枚刃(テーパージャック)	4-Flute Hi-Helical Long Flute End Mills (Drawing Thread Taper Shank)	57
SL-ST	スロットングエンドミル2枚刃(ストレートジャック)	2-Flute Slotting End Mills (Straight Shank)	58
SL-BS	スロットングエンドミル2枚刃(BSジャック)	2-Flute Slotting End Mills (BS Shank)	59
SL-MT	スロットングエンドミル2枚刃(MTジャック)	2-Flute Slotting End Mills (MT Shank)	59
SL-BS-L	ロングスロットングエンドミル2枚刃(BSジャック)	2-Flute Long Flute Slotting End Mills (BS Shank)	60
SP-MT	スパイラルエンドミル(MTジャック)	Left Hand Spiral End Mills (MT Shank)	60
SP-BS	スパイラルエンドミル(BSジャック)	Left Hand Spiral End Mills (BS Shank)	61
SP-BS-L	ロングスパイラルエンドミル(BSジャック)	Left Hand, Long Flute Spiral End Mills (BS Shank)	61
KC	キーシートカッター	Woodruff Keyseat Cutters	62 ~ 70
KCST	側刃付キーシートカッター	Woodruff Keyseat Cutters with Side Tooth	71
TC	Tスロットカッター	T-Slot Cutters, Straight Tooth	72 ~ 79
LS-TC	ロングジャックTスロットカッター	T-Slot Cutters, Straight Tooth (Long Shank)	80 ~ 81
STC	千鳥刃Tスロットカッター	T-Slot Cutters, Staggered Tooth	82 ~ 89
LS-STC	ロングジャック千鳥刃Tスロットカッター	T-Slot Cutters, Staggered Tooth (Long Shank)	90 ~ 93
	(TC / LS-TC) (STC / LS-STC) 両サイド刃の長さ	Technical Information (Length of Side Tooth)	94
TSE	Tスロットエンドミル	T-Slot End Mills	95 ~ 96
SAC	柄付アングルカッター	Dovetail Cutters	97
SWC	柄付ダブルアングルカッター	Double Angle Cutters (Shank Type W Angle Cutters)	98
SPC	柄付傘型カッター	Face Angle Cutters (Shank Type Angle Cutters)	98
CR	センターリーマ	Center Reamers	99
CR-MT	センターリーマ(テーパージャック)	Center Reamers (MT Shank)	99
CC	チャタレス面取フライス	Chatterless Countersinks	100
3C	3Cミル(六角穴付ボルトMC用面取付座繰りカッター)	3C Mills (Centering, Counterbore & Chamfering)	100
CB	沈めフライス(六角穴付ボルト用)	Cap Screw Counterbores	101
CBT	沈めフライス(六角穴付ボルト用)テーパージャック	Cap Screw Counterbores (MT Shank)	101
EP-CB	押し出しピン用沈めフライス	Ejector Pin Counterbores	102
MS-CB	皿小ネジ用沈めフライス	Machine Screw Counterbores	102
LS-CB	ロングジャック沈めフライス(JIS規格)	Long Shank Cap Screw Counterbores (JIS Cap Screw)	102
DCB	ドリル付沈めフライス(六角穴付ボルト用)	Cap Screw Counterbores with Drill	103

# INDEX

型番	品名	ページ
DCS	ドリル付皿小ネジ用沈めフライス <i>Machine Screw Counterbores with Drill</i>	103
DSS	ドリル付皿小ネジ下穴用沈めフライス <i>Machine Screw Counterbores with Drill Pre-Tapping Sizes</i>	103
SC	サイドカッター <i>Side Milling Cutters (Straight Tooth)</i>	104 ~ 107
SSC	千鳥刃サイドカッター <i>Side Milling Cutters (Staggered Tooth)</i>	108 ~ 111
AC-RH	シングルアングルカッター(右刃) <i>Single Angle Cutters (Right Hand)</i>	112 ~ 114
AC-LH	シングルアングルカッター(左刃) <i>Single Angle Cutters (Left Hand)</i>	115 ~ 117
WAC	ダブルアングルカッター <i>Double Angle Cutters</i>	118 ~ 120
SRM	3SストレートシャンクドリルR型 [六角穴付ボルト用(キャップボルト)] <i>3S Straight Shank Drills R Type</i>	121
SSM	3SストレートシャンクドリルS型 [皿小ねじ用] <i>3S Straight Shank Drills S Type</i>	121
SHM	3SストレートシャンクドリルH型 [平小ねじ用] <i>3S Straight Shank Drills H Type</i>	121
SD	超硬付刃ストレートシャンクドリル <i>Straight Shank Drills G-2 Carbide Tipped</i>	122
TD	超硬付刃テーパシャンクドリル <i>Taper Shank Drills G-2 Carbide Tipped</i>	123 ~ 125
SSD	超硬先ムクストレートシャンクドリル <i>Straight Shank Drills G-2 Top Solid Carbide</i>	126
STD	超硬先ムクテーパシャンクドリル <i>Taper Shank Drills G-2 Top Solid Carbide</i>	126
SLD	超硬付刃スリムシャンクドリル <i>Collet Use Carbide Tipped Drills</i>	127
EMCR	EMCスーパードリル・レギュラー形 <i>EMC Super Drills Regular</i>	128
EMCS	EMCスーパードリル・スタブ形 <i>EMC Super Drills Stub</i>	129

(2SF)  
3Sエンドミル 2枚刃(標準刃)  
2-Flute Standard End Mills

SINCE 1935  
F.K.D.®

材質=HSS-Co  
刃数=2枚  
リード角=右捩れ30°  
刃径公差=0~-0.03

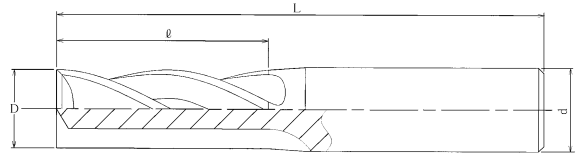
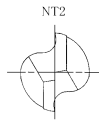

●注文例=型番、刃径、数量 「2SF 0.8」 ※φ40径以上のサイズはシャンク径もご指定下さい。

型番	刃径 (D)	刃長 (ℓ)	全長 (L)	シャンク径 (d)	標準価格
2SF	0.8	2	42	6	6,600
2SF	0.9	2	42	6	6,600
2SF	1	2.5	42	6	4,900
2SF	1.1	2.5	42	6	6,400
2SF	1.2	2.5	42	6	6,400
2SF	1.3	2.5	42	6	6,400
2SF	1.4	4	45	6	6,400
2SF	1.5	4	45	6	4,600
2SF	1.6	4	45	6	5,900
2SF	1.7	4	45	6	5,900
2SF	1.8	5	45	6	5,400
2SF	1.9	5	45	6	5,400
2SF	2	5	45	6	4,300
2SF	2.1	5	45	6	5,400
2SF	2.2	5	45	6	5,400
2SF	2.3	7	45	6	5,400
2SF	2.4	7	45	6	5,400
2SF	2.5	7	45	6	4,300
2SF	2.6	7	45	6	5,400
2SF	2.7	7	45	6	5,400
2SF	2.8	10	48	6	5,400
2SF	2.9	10	48	6	5,400
2SF	3	10	48	6	3,600
2SF	3.1	10	48	6	4,400
2SF	3.2	10	48	6	4,400
2SF	3.3	10	48	6	4,400
2SF	3.4	10	48	6	4,400
2SF	3.5	12	50	6	3,600
2SF	3.6	12	50	6	4,400
2SF	3.7	12	50	6	4,400
2SF	3.8	12	50	6	4,400
2SF	3.9	12	50	6	4,400
2SF	4	12	50	6	3,600
2SF	4.1	12	50	6	4,400
2SF	4.2	12	50	6	4,400
2SF	4.3	12	50	6	4,400
2SF	4.4	12	50	6	4,400
2SF	4.5	14	52	6	3,600
2SF	4.6	14	52	6	4,400
2SF	4.7	14	52	6	4,400
2SF	4.8	14	52	6	4,400
2SF	4.9	14	52	6	4,400
2SF	5	14	52	6	3,600
2SF	5.1	14	52	6	4,400
2SF	5.2	14	52	6	4,400
2SF	5.3	14	52	6	4,400
2SF	5.4	14	52	6	4,400
2SF	5.5	16	54	6	3,600
2SF	5.6	16	54	6	4,400

型番	刃径 (D)	刃長 (ℓ)	全長 (L)	シャンク径 (d)	標準価格
2SF	5.7	16	54	6	4,400
2SF	5.8	16	54	6	4,400
2SF	5.9	16	54	6	4,400
2SF	6	16	54	6	3,600
2SF	6.1	16	54	6	4,900
2SF	6.2	16	54	8	4,900
2SF	6.3	16	54	8	4,900
2SF	6.4	16	54	8	4,900
2SF	6.5	18	56	8	3,800
2SF	6.6	18	56	8	4,900
2SF	6.7	18	56	8	4,900
2SF	6.8	18	56	8	4,900
2SF	6.9	18	56	8	4,900
2SF	7	18	56	8	3,800
2SF	7.1	18	56	8	4,900
2SF	7.2	18	56	8	4,900
2SF	7.3	18	56	8	4,900
2SF	7.4	18	56	8	4,900
2SF	7.5	20	58	8	3,800
2SF	7.6	20	58	8	4,900
2SF	7.7	20	58	8	4,900
2SF	7.8	20	58	8	4,900
2SF	7.9	20	58	8	4,900
2SF	8	20	58	8	3,800
2SF	8.1	20	58	8	5,600
2SF	8.2	20	58	10	5,600
2SF	8.3	20	58	10	5,600
2SF	8.4	20	58	10	5,600
2SF	8.5	22	60	10	4,400
2SF	8.6	22	60	10	5,600
2SF	8.7	22	60	10	5,600
2SF	8.8	22	60	10	5,600
2SF	8.9	22	60	10	5,600
2SF	9	22	60	10	4,400
2SF	9.1	22	60	10	5,600
2SF	9.2	22	60	10	5,600
2SF	9.3	22	60	10	5,600
2SF	9.4	22	60	10	5,600
2SF	9.5	25	63	10	4,400
2SF	9.6	25	63	10	5,600
2SF	9.7	25	63	10	5,600
2SF	9.8	25	63	10	5,600
2SF	9.9	25	63	10	5,600
2SF	10	25	63	10	4,400
2SF	10.1	25	63	10	6,800
2SF	10.2	25	63	12	6,800
2SF	10.3	25	63	12	6,800
2SF	10.4	25	63	12	6,800
2SF	10.5	28	73	12	5,400

(2SF)  
3Sエンドミル 2枚刃(標準刃)  
2-Flute Standard End Mills

SINCE 1935  
F.K.D.®

材質=HSS-Co  
刃数=2枚  
リード角=右捩れ30°  
刃径公差=0~-0.03

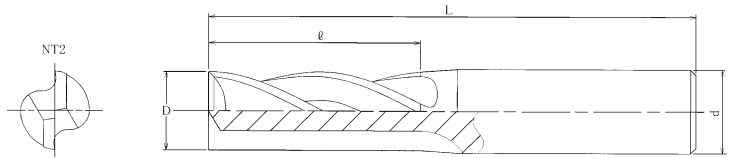

●注文例=型番、刃径、数量「2SF 10.6」 ※φ40径以上のサイズはシャンク径もご指定下さい。

型番	刃径 (D)	刃長 (ℓ)	全長 (L)	シャンク径 (d)	標準価格
2SF	10.6	28	73	12	6,800
2SF	10.7	28	73	12	6,800
2SF	10.8	28	73	12	6,800
2SF	10.9	28	73	12	6,800
2SF	11	28	73	12	5,400
2SF	11.1	28	73	12	6,800
2SF	11.2	28	73	12	6,800
2SF	11.3	28	73	12	6,800
2SF	11.4	28	73	12	6,800
2SF	11.5	30	80	12	6,800
2SF	11.6	30	80	12	6,800
2SF	11.7	30	80	12	6,800
2SF	11.8	30	80	12	6,800
2SF	11.9	30	80	12	6,800
2SF	12	30	80	12	5,400
2SF	12.1	30	80	12	7,900
2SF	12.2	30	80	12	7,900
2SF	12.3	30	80	12	7,900
2SF	12.4	30	80	12	7,900
2SF	12.5	35	85	12	7,900
2SF	12.6	35	85	12	7,900
2SF	12.7	35	85	12	7,900
2SF	12.8	35	85	12	7,900
2SF	12.9	35	85	12	7,900
2SF	13	35	85	12	6,600
2SF	13.1	35	85	12	7,900
2SF	13.2	35	85	12	7,900
2SF	13.3	35	85	12	7,900
2SF	13.4	35	85	12	7,900
2SF	13.5	35	85	12	7,900
2SF	13.6	35	85	12	7,900
2SF	13.7	35	85	12	7,900
2SF	13.8	35	85	12	7,900
2SF	13.9	35	85	12	7,900
2SF	14	35	85	12	6,600
2SF	14.1	35	85	12	9,100
2SF	14.2	35	85	12	9,100
2SF	14.3	35	85	12	9,100
2SF	14.4	35	85	12	9,100
2SF	14.5	40	92	16	9,100
2SF	14.6	40	92	16	9,100
2SF	14.7	40	92	16	9,100
2SF	14.8	40	92	16	9,100
2SF	14.9	40	92	16	9,100
2SF	15	40	92	16	7,500
2SF	15.1	40	92	16	9,800
2SF	15.2	40	92	16	9,800
2SF	15.3	40	92	16	9,800
2SF	15.4	40	92	16	9,800

型番	刃径 (D)	刃長 (ℓ)	全長 (L)	シャンク径 (d)	標準価格
2SF	15.5	40	92	16	9,800
2SF	15.6	40	92	16	9,800
2SF	15.7	40	92	16	9,800
2SF	15.8	40	92	16	9,800
2SF	15.9	40	92	16	9,800
2SF	16	40	92	16	7,700
2SF	16.1	40	92	16	12,400
2SF	16.2	40	92	16	12,400
2SF	16.3	40	92	16	12,400
2SF	16.4	40	92	16	12,400
2SF	16.5	40	95	16	12,400
2SF	16.6	40	95	16	12,400
2SF	16.7	40	95	16	12,400
2SF	16.8	40	95	16	12,400
2SF	16.9	40	95	16	12,400
2SF	17	40	95	16	9,800
2SF	17.1	40	95	16	12,400
2SF	17.2	40	95	16	12,400
2SF	17.3	40	95	16	12,400
2SF	17.4	40	95	16	12,400
2SF	17.5	40	95	16	12,400
2SF	17.6	40	95	16	12,400
2SF	17.7	40	95	16	12,400
2SF	17.8	40	95	16	12,400
2SF	17.9	40	95	16	12,400
2SF	18	40	95	16	9,800
2SF	18.1	40	95	16	15,200
2SF	18.2	40	95	16	15,200
2SF	18.3	40	95	16	15,200
2SF	18.4	40	95	16	15,200
2SF	18.5	45	110	20	15,200
2SF	18.6	45	110	20	15,200
2SF	18.7	45	110	20	15,200
2SF	18.8	45	110	20	15,200
2SF	18.9	45	110	20	15,200
2SF	19	45	110	20	12,300
2SF	19.1	45	110	20	15,200
2SF	19.2	45	110	20	15,200
2SF	19.3	45	110	20	15,200
2SF	19.4	45	110	20	15,200
2SF	19.5	45	110	20	15,200
2SF	19.6	45	110	20	15,200
2SF	19.7	45	110	20	15,200
2SF	19.8	45	110	20	15,200
2SF	19.9	45	110	20	15,200
2SF	20	45	110	20	12,300
2SF	20.1	45	110	20	18,600
2SF	20.2	45	110	20	18,600
2SF	20.3	45	110	20	18,600

(2SF)  
3Sエンドミル 2枚刃(標準刃)  
2-Flute Standard End Mills



材質=HSS-Co  
刃数=2枚  
リード角=右捩れ30°  
刃径公差=0~-0.03

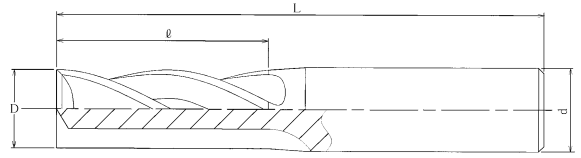
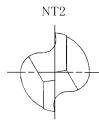

●注文例=型番、刃径、数量 「2SF 20.4」 ※φ40径以上のサイズはシャンク径もご指定下さい。

型番	刃径 (D)	刃長 (ℓ)	全長 (L)	シャンク径 (d)	標準価格
2SF	20.4	45	110	20	18,600
2SF	20.5	45	110	20	18,600
2SF	20.6	45	110	20	18,600
2SF	20.7	45	110	20	18,600
2SF	20.8	45	110	20	18,600
2SF	20.9	45	110	20	18,600
2SF	21	45	110	20	14,900
2SF	21.1	45	110	20	18,600
2SF	21.2	45	110	20	18,600
2SF	21.3	45	110	20	18,600
2SF	21.4	45	110	20	18,600
2SF	21.5	45	110	20	18,600
2SF	21.6	45	110	20	18,600
2SF	21.7	45	110	20	18,600
2SF	21.8	45	110	20	18,600
2SF	21.9	45	110	20	18,600
2SF	22	45	110	20	14,900
2SF	22.1	45	110	20	21,600
2SF	22.2	45	110	20	21,600
2SF	22.3	45	110	20	21,600
2SF	22.4	45	110	20	21,600
2SF	22.5	50	120	25	21,600
2SF	22.6	50	120	25	21,600
2SF	22.7	50	120	25	21,600
2SF	22.8	50	120	25	21,600
2SF	22.9	50	120	25	21,600
2SF	23	50	120	25	17,200
2SF	23.1	50	120	25	21,600
2SF	23.2	50	120	25	21,600
2SF	23.3	50	120	25	21,600
2SF	23.4	50	120	25	21,600
2SF	23.5	50	120	25	21,600
2SF	23.6	50	120	25	21,600
2SF	23.7	50	120	25	21,600
2SF	23.8	50	120	25	21,600
2SF	23.9	50	120	25	21,600
2SF	24	50	120	25	17,200
2SF	24.1	50	120	25	21,600
2SF	24.2	50	120	25	21,600
2SF	24.3	50	120	25	21,600
2SF	24.4	50	120	25	21,600
2SF	24.5	50	120	25	21,600
2SF	24.6	50	120	25	21,600
2SF	24.7	50	120	25	21,600
2SF	24.8	50	120	25	21,600
2SF	24.9	50	120	25	21,600
2SF	25	50	120	25	17,200
2SF	25.1	50	120	25	23,700
2SF	25.2	50	120	25	23,700

型番	刃径 (D)	刃長 (ℓ)	全長 (L)	シャンク径 (d)	標準価格
2SF	25.3	50	120	25	23,700
2SF	25.4	50	120	25	23,700
2SF	25.5	50	120	25	23,700
2SF	25.6	50	120	25	23,700
2SF	25.7	50	120	25	23,700
2SF	25.8	50	120	25	23,700
2SF	25.9	50	120	25	23,700
2SF	26	50	120	25	19,000
2SF	26.1	50	120	25	27,800
2SF	26.2	50	120	25	27,800
2SF	26.3	50	120	25	27,800
2SF	26.4	50	120	25	27,800
2SF	26.5	55	125	25	27,800
2SF	26.6	55	125	25	27,800
2SF	26.7	55	125	25	27,800
2SF	26.8	55	125	25	27,800
2SF	26.9	55	125	25	27,800
2SF	27	55	125	25	22,200
2SF	27.1	55	125	25	27,800
2SF	27.2	55	125	25	27,800
2SF	27.3	55	125	25	27,800
2SF	27.4	55	125	25	27,800
2SF	27.5	55	125	25	27,800
2SF	27.6	55	125	25	27,800
2SF	27.7	55	125	25	27,800
2SF	27.8	55	125	25	27,800
2SF	27.9	55	125	25	27,800
2SF	28	55	125	25	22,200
2SF	28.1	55	125	25	34,200
2SF	28.2	55	125	25	34,200
2SF	28.3	55	125	25	34,200
2SF	28.4	55	125	25	34,200
2SF	28.5	55	125	25	34,200
2SF	28.6	55	125	25	34,200
2SF	28.7	55	125	25	34,200
2SF	28.8	55	125	25	34,200
2SF	28.9	55	125	25	34,200
2SF	29	55	125	25	27,700
2SF	29.1	55	125	25	34,200
2SF	29.2	55	125	25	34,200
2SF	29.3	55	125	25	34,200
2SF	29.4	55	125	25	34,200
2SF	29.5	55	125	25	34,200
2SF	29.6	55	125	25	34,200
2SF	29.7	55	125	25	34,200
2SF	29.8	55	125	25	34,200
2SF	29.9	55	125	25	34,200
2SF	30	55	125	25	27,700
2SF	30.1	55	125	25	40,700

(2SF)  
3Sエンドミル 2枚刃(標準刃)  
2-Flute Standard End Mills

SINCE 1935  
F.K.D.®

材質=HSS-Co  
刃数=2枚  
リード角=右捩れ30°  
刃径公差=0~-0.03

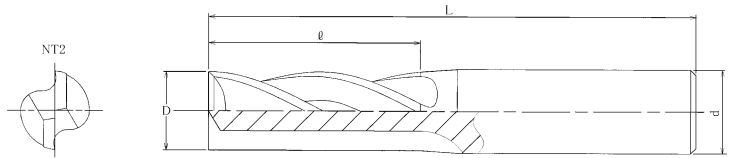

●注用例=型番、刃径、数量 「2SF 30.2」 ※φ40径以上のサイズはシャンク径もご指定下さい。

型番	刃径 (D)	刃長 (ℓ)	全長 (L)	シャンク径 (d)	標準価格
2SF	30.2	55	125	25	40,700
2SF	30.3	55	125	25	40,700
2SF	30.4	55	125	25	40,700
2SF	30.5	60	130	32	40,700
2SF	30.6	60	130	32	40,700
2SF	30.7	60	130	32	40,700
2SF	30.8	60	130	32	40,700
2SF	30.9	60	130	32	40,700
2SF	31	60	130	32	32,700
2SF	31.1	60	130	32	40,700
2SF	31.2	60	130	32	40,700
2SF	31.3	60	130	32	40,700
2SF	31.4	60	130	32	40,700
2SF	31.5	60	130	32	40,700
2SF	31.6	60	130	32	40,700
2SF	31.7	60	130	32	40,700
2SF	31.8	60	130	32	40,700
2SF	31.9	60	130	32	40,700
2SF	32	60	130	32	32,700
2SF	32.1	60	130	32	46,300
2SF	32.2	60	130	32	46,300
2SF	32.3	60	130	32	46,300
2SF	32.4	60	130	32	46,300
2SF	32.5	60	140	32	46,300
2SF	32.6	60	140	32	46,300
2SF	32.7	60	140	32	46,300
2SF	32.8	60	140	32	46,300
2SF	32.9	60	140	32	46,300
2SF	33	60	140	32	37,800
2SF	33.1	60	140	32	46,300
2SF	33.2	60	140	32	46,300
2SF	33.3	60	140	32	46,300
2SF	33.4	60	140	32	46,300
2SF	33.5	60	140	32	46,300
2SF	33.6	60	140	32	46,300
2SF	33.7	60	140	32	46,300
2SF	33.8	60	140	32	46,300
2SF	33.9	60	140	32	46,300
2SF	34	60	140	32	37,800
2SF	34.1	60	140	32	48,200
2SF	34.2	60	140	32	48,200
2SF	34.3	60	140	32	48,200
2SF	34.4	60	140	32	48,200
2SF	34.5	60	140	32	48,200
2SF	34.6	60	140	32	48,200
2SF	34.7	60	140	32	48,200
2SF	34.8	60	140	32	48,200
2SF	34.9	60	140	32	48,200
2SF	35	60	140	32	39,400

型番	刃径 (D)	刃長 (ℓ)	全長 (L)	シャンク径 (d)	標準価格
2SF	35.1	60	140	32	51,700
2SF	35.2	60	140	32	51,700
2SF	35.3	60	140	32	51,700
2SF	35.4	60	140	32	51,700
2SF	35.5	60	140	32	51,700
2SF	35.6	60	140	32	51,700
2SF	35.7	60	140	32	51,700
2SF	35.8	60	140	32	51,700
2SF	35.9	60	140	32	51,700
2SF	36	60	140	32	42,900
2SF	36.1	60	140	32	57,200
2SF	36.2	60	140	32	57,200
2SF	36.3	60	140	32	57,200
2SF	36.4	60	140	32	57,200
2SF	36.5	65	145	32	57,200
2SF	36.6	65	145	32	57,200
2SF	36.7	65	145	32	57,200
2SF	36.8	65	145	32	57,200
2SF	36.9	65	145	32	57,200
2SF	37	65	145	32	47,300
2SF	37.1	65	145	32	57,200
2SF	37.2	65	145	32	57,200
2SF	37.3	65	145	32	57,200
2SF	37.4	65	145	32	57,200
2SF	37.5	65	145	32	57,200
2SF	37.6	65	145	32	57,200
2SF	37.7	65	145	32	57,200
2SF	37.8	65	145	32	57,200
2SF	37.9	65	145	32	57,200
2SF	38	65	145	32	47,300
2SF	38.1	65	145	32	65,900
2SF	38.2	65	145	32	65,900
2SF	38.3	65	145	32	65,900
2SF	38.4	65	145	32	65,900
2SF	38.5	65	145	32	65,900
2SF	38.6	65	145	32	65,900
2SF	38.7	65	145	32	65,900
2SF	38.8	65	145	32	65,900
2SF	38.9	65	145	32	65,900
2SF	39	65	145	32	54,700
2SF	39.1	65	145	32	65,900
2SF	39.2	65	145	32	65,900
2SF	39.3	65	145	32	65,900
2SF	39.4	65	145	32	65,900
2SF	39.5	65	145	32	65,900
2SF	39.6	65	145	32	65,900
2SF	39.7	65	145	32	65,900
2SF	39.8	65	145	32	65,900
2SF	39.9	65	145	32	65,900

(2SF)  
3Sエンドミル 2枚刃(標準刃)  
2-Flute Standard End Mills

SINCE 1935  
F.K.D.®

材質=HSS-Co  
刃数=2枚  
リード角=右捩れ30°  
刃径公差=0~-0.03

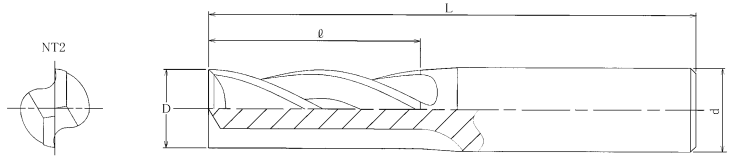

●注文例=型番、刃径、シャンク径、数量「2SF 40x32」※φ40径以上のサイズはシャンク径もご指定下さい。

型番	刃径 (D)	刃長 (ℓ)	全長 (L)	シャンク径 (d)	標準価格
2SF	40	65	145	32	54,700
2SF	40	65	160	42	57,200
2SF	40.1	65	150	32	73,700
2SF	40.2	65	150	32	73,700
2SF	40.3	65	150	32	73,700
2SF	40.4	65	150	32	73,700
2SF	40.5	65	150	32	73,700
2SF	40.5	65	160	42	73,700
2SF	40.6	65	150	32	73,700
2SF	40.7	65	150	32	73,700
2SF	40.8	65	150	32	73,700
2SF	40.9	65	150	32	73,700
2SF	41	65	150	32	61,500
2SF	41	65	160	42	64,000
2SF	41.1	65	150	32	73,700
2SF	41.2	65	150	32	73,700
2SF	41.3	65	150	32	73,700
2SF	41.4	65	150	32	73,700
2SF	41.5	65	150	32	73,700
2SF	41.5	65	160	42	73,700
2SF	41.6	65	150	32	96,100
2SF	41.7	65	150	32	96,100
2SF	41.8	65	150	32	96,100
2SF	41.9	65	150	32	96,100
2SF	42	65	150	32	61,500
2SF	42	65	160	42	64,000
2SF	42.1	70	155	32	85,700
2SF	42.2	70	155	32	85,700
2SF	42.3	70	155	32	85,700
2SF	42.4	70	155	32	85,700
2SF	42.5	70	155	32	85,700
2SF	42.5	70	165	42	85,700
2SF	42.6	70	155	32	85,700
2SF	42.7	70	155	32	85,700
2SF	42.8	70	155	32	85,700
2SF	42.9	70	155	32	85,700
2SF	43	70	155	32	71,900
2SF	43	70	165	42	74,900
2SF	43.1	70	155	32	85,700
2SF	43.2	70	155	32	85,700
2SF	43.3	70	155	32	85,700
2SF	43.4	70	155	32	85,700
2SF	43.5	70	155	32	85,700
2SF	43.5	70	165	42	85,700
2SF	43.6	70	155	32	85,700
2SF	43.7	70	155	32	85,700
2SF	43.8	70	155	32	85,700
2SF	43.9	70	155	32	85,700
2SF	44	70	155	32	71,900

型番	刃径 (D)	刃長 (ℓ)	全長 (L)	シャンク径 (d)	標準価格
2SF	44	70	165	42	74,900
2SF	44.1	70	155	32	92,500
2SF	44.2	70	155	32	92,500
2SF	44.3	70	155	32	92,500
2SF	44.4	70	155	32	92,500
2SF	44.5	70	155	32	92,500
2SF	44.5	70	165	42	92,500
2SF	44.6	70	155	32	92,500
2SF	44.7	70	155	32	92,500
2SF	44.8	70	155	32	92,500
2SF	44.9	70	155	32	92,500
2SF	45	70	155	32	78,500
2SF	45	70	165	42	81,800
2SF	45.5	70	155	32	92,500
2SF	45.5	70	165	42	92,500
2SF	46	70	155	32	78,500
2SF	46	70	165	42	81,800
2SF	46.5	70	155	32	96,100
2SF	46.5	70	165	42	96,100
2SF	47	70	155	32	82,300
2SF	47	70	165	42	85,700
2SF	47.5	70	155	32	96,100
2SF	47.5	70	165	42	96,100
2SF	48	70	155	32	82,300
2SF	48	70	165	42	85,700
2SF	48.5	70	155	32	106,900
2SF	48.5	70	165	42	106,900
2SF	49	70	155	32	92,200
2SF	49	70	165	42	96,100
2SF	49.5	70	155	32	106,900
2SF	49.5	70	165	42	106,900
2SF	50	70	155	32	92,200
2SF	50	70	165	42	96,100
2SF	50.5	70	155	32	112,200
2SF	50.5	70	165	42	112,200
2SF	51	70	155	32	107,700
2SF	51	70	165	42	112,200
2SF	52	70	155	32	107,700
2SF	52	70	165	42	112,200
2SF	53	75	160	32	117,900
2SF	53	75	170	42	122,900
2SF	54	75	160	32	117,900
2SF	54	75	170	42	122,900
2SF	55	75	160	32	117,900
2SF	55	75	170	42	122,900
2SF	56	75	160	32	129,900
2SF	56	75	170	42	135,100
2SF	57	75	160	32	129,900
2SF	57	75	170	42	135,100



(2SF)  
3Sエンドミル 2枚刃(標準刃)  
2-Flute Standard End Mills

SINCE 1935  
F.K.D.®

材質=HSS-Co  
刃数=2枚  
リード角=右捩れ30°  
刃径公差=0~-0.03

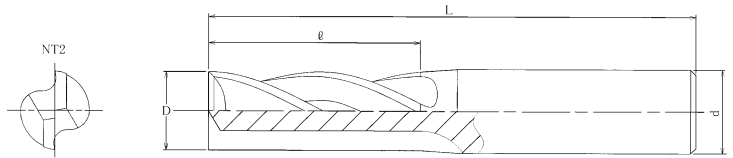

●注用例=型番、刃径、シャンク径、数量「2SF 58x32」※φ40径以上のサイズはシャンク径もご指定下さい。

型番	刃径 (D)	刃長 (ℓ)	全長 (L)	シャンク径 (d)	標準価格
2SF	58	75	160	32	129,900
2SF	58	75	170	42	135,100
2SF	59	75	160	32	138,600
2SF	59	75	170	42	144,300
2SF	60	75	160	32	138,600
2SF	60	75	170	42	144,300
2SF	61	80	165	32	165,800
2SF	61	80	175	42	172,800
2SF	62	80	165	32	165,800
2SF	62	80	175	42	172,800
2SF	63	80	165	32	193,200
2SF	63	80	175	42	201,200
2SF	64	80	165	32	193,200
2SF	64	80	175	42	201,200
2SF	65	80	165	32	193,200
2SF	65	80	175	42	201,200
2SF	66	80	165	32	193,200
2SF	66	80	175	42	201,200
2SF	67	80	165	32	193,200
2SF	67	80	175	42	201,200
2SF	68	80	165	32	213,400
2SF	68	80	175	42	222,400
2SF	69	80	165	32	213,400
2SF	69	80	175	42	222,400
2SF	70	80	165	32	213,400
2SF	70	80	175	42	222,400
2SF	71	80	180	32	252,900
2SF	71	80	180	42	263,300

型番	刃径 (D)	刃長 (ℓ)	全長 (L)	シャンク径 (d)	標準価格
2SF	72	80	180	32	252,900
2SF	72	80	180	42	263,300
2SF	73	80	180	32	252,900
2SF	73	80	180	42	263,300
2SF	74	80	180	32	252,900
2SF	74	80	180	42	263,300
2SF	75	80	180	32	252,900
2SF	75	80	180	42	263,300
2SF	76	80	180	32	288,400
2SF	76	80	180	42	300,500
2SF	77	80	180	32	288,400
2SF	77	80	180	42	300,500
2SF	78	80	180	32	288,400
2SF	78	80	180	42	300,500
2SF	79	80	180	32	288,400
2SF	79	80	180	42	300,500
2SF	80	80	180	32	288,400
2SF	80	80	180	42	300,500
2SF	85	80	180	32	316,100
2SF	85	80	180	42	329,100
2SF	90	80	180	32	339,800
2SF	90	80	180	42	354,000
2SF	95	80	180	32	372,100
2SF	95	80	180	42	387,800
2SF	100	80	180	32	394,500
2SF	100	80	180	42	410,900

●注用例=型番、刃径、数量「2SF 1/16"」

○インチサイズ

型番	刃径 (D)	刃長 (ℓ)	全長 (L)	シャンク径 (d)	標準価格
2SF	1/16"	4	45	6	6,700
2SF	3/32"	7	45	6	5,900
2SF	1/8"	10	48	6	4,900
2SF	5/32"	12	50	6	4,900
2SF	3/16"	14	52	6	4,900
2SF	7/32"	16	54	6	4,900
2SF	1/4"	16	54	8	5,400
2SF	5/16"	20	58	8	5,400
2SF	3/8"	25	63	10	6,500
2SF	7/16"	28	73	12	7,600

○インチサイズ

型番	刃径 (D)	刃長 (ℓ)	全長 (L)	シャンク径 (d)	標準価格
2SF	1/2"	35	85	12	7,900
2SF	9/16"	35	85	12	11,000
2SF	5/8"	40	92	16	11,900
2SF	11/16"	40	95	16	13,400
2SF	3/4"	45	110	20	16,700
2SF	13/16"	45	110	20	20,400
2SF	7/8"	45	110	20	23,700
2SF	15/16"	50	120	25	23,700
2SF	1"	50	120	25	23,700
2SF	1.1/4"	60	130	32	44,600

# (2LF / 2XLF) 3Sエンドミル 2枚刃(ロング・特ロング刃)

SINCE 1935  
F.K.D.®

2-Flute Long & Extra Long End Mills

材質=HSS-Co  
刃数=2枚  
リード角=右捩れ30°  
刃径公差=0~-0.03

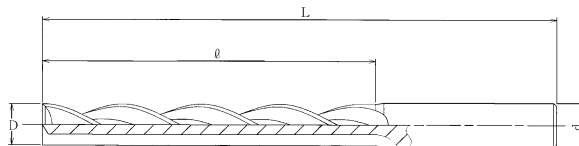

●注文例=型番、刃径、刃長、数量 「2XLF 0.8x2.5」 ※φ40径以上のサイズはシャンク径もご指定下さい。

型番	刃径 (D)	刃長 (l)	全長 (L)	シャンク径 (d)	標準価格
2XLF	0.8	2.5	42	6	8,200
2XLF	0.9	2.5	42	6	8,200
2XLF	1	5	50	6	9,800
2XLF	1	6	50	6	9,800
2XLF	1	7.5	50	6	11,300
2XLF	1.1	7.5	50	6	10,200
2XLF	1.2	7.5	50	6	10,200
2XLF	1.3	7.5	50	6	10,200
2XLF	1.4	7.5	50	6	10,200
2XLF	1.5	7.5	50	6	8,400
2XLF	1.5	10	60	6	9,200
2XLF	1.6	10	60	6	9,200
2XLF	1.7	10	60	6	9,200
2XLF	1.8	10	60	6	9,200
2XLF	1.9	10	60	6	9,200
2XLF	2	10	60	6	6,500
2XLF	2	12	60	6	7,100
2XLF	2	15	60	6	8,300
2XLF	2.1	15	60	6	8,500
2XLF	2.2	15	60	6	8,500
2XLF	2.3	15	60	6	8,500
2XLF	2.4	15	60	6	8,500
2XLF	2.5	12	60	6	6,600
2XLF	2.5	15	60	6	7,400
2XLF	2.5	20	60	6	11,200
2XLF	2.6	15	60	6	8,200
2XLF	2.6	20	60	6	12,000
2XLF	2.7	15	60	6	8,200
2XLF	2.7	20	60	6	12,000
2XLF	2.8	15	60	6	8,200
2XLF	2.8	20	60	6	12,000
2XLF	2.9	15	60	6	8,200
2XLF	2.9	20	60	6	12,000
2LF	3	15	53	6	4,400
2XLF	3	20	58	6	4,400
2XLF	3	25	60	6	4,400
2XLF	3	30	70	6	4,400
2XLF	3	40	80	6	5,600
2LF	3.1	15	53	6	5,600
2XLF	3.1	30	70	6	7,100
2LF	3.2	15	53	6	5,600
2XLF	3.2	30	70	6	7,100
2LF	3.3	15	53	6	5,600
2XLF	3.3	30	70	6	7,100
2LF	3.4	15	53	6	5,600
2XLF	3.4	30	70	6	7,100

型番	刃径 (D)	刃長 (l)	全長 (L)	シャンク径 (d)	標準価格
2LF	3.5	20	59	6	5,600
2XLF	3.5	30	70	6	5,600
2XLF	3.5	40	80	6	7,200
2LF	3.6	20	59	6	5,600
2XLF	3.6	30	70	6	7,100
2LF	3.7	20	59	6	5,600
2XLF	3.7	30	70	6	7,100
2LF	3.8	20	59	6	5,600
2XLF	3.8	30	70	6	7,100
2LF	3.9	20	59	6	5,600
2XLF	3.9	30	70	6	7,100
2LF	4	20	59	6	4,400
2XLF	4	30	70	6	4,400
2XLF	4	40	80	6	5,600
2XLF	4	50	90	6	6,700
2LF	4.1	20	59	6	5,600
2XLF	4.1	30	70	6	9,000
2LF	4.2	20	59	6	5,600
2XLF	4.2	30	70	6	9,000
2LF	4.3	20	59	6	5,600
2XLF	4.3	30	70	6	9,000
2LF	4.4	20	59	6	5,600
2XLF	4.4	30	70	6	9,000
2LF	4.5	25	64	6	5,600
2XLF	4.5	30	70	6	5,600
2XLF	4.5	40	80	6	7,200
2XLF	4.5	50	90	6	8,400
2LF	4.6	25	64	6	5,600
2XLF	4.6	40	80	6	9,000
2LF	4.7	25	64	6	5,600
2XLF	4.7	40	80	6	9,000
2LF	4.8	25	64	6	5,600
2XLF	4.8	40	80	6	9,000
2LF	4.9	25	64	6	5,600
2XLF	4.9	40	80	6	9,000
2LF	5	25	64	6	4,400
2XLF	5	30	70	6	4,400
2XLF	5	40	80	6	5,600
2XLF	5	50	90	6	6,700
2XLF	5	60	100	6	7,100
2LF	5.1	25	64	6	5,600
2XLF	5.1	40	80	6	9,000
2LF	5.2	25	64	6	5,600
2XLF	5.2	40	80	6	9,000
2LF	5.3	25	64	6	5,600
2XLF	5.3	40	80	6	9,000

(2LF / 2XLF)  
**3Sエンドミル 2枚刃(ロング・特ロング刃)**  
 2-Flute Long & Extra Long End Mills



材質=HSS-Co  
 刃数=2枚  
 リード角=右捩れ30°  
 刃径公差=0~-0.03

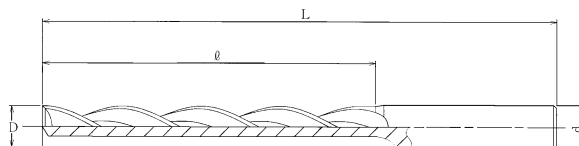

●注文例=型番、刃径、刃長、数量 「2XLF 6.5x50」 ※φ40径以上のサイズはシャンク径もご指定下さい。

型番	刃径 (D)	刃長 (l)	全長 (L)	シャンク径 (d)	標準価格
2LF	5.4	25	64	6	5,600
2XLF	5.4	40	80	6	9,000
2LF	5.5	30	69	6	5,600
2XLF	5.5	40	80	6	7,200
2XLF	5.5	50	90	6	8,400
2XLF	5.5	60	100	6	8,500
2LF	5.6	30	69	6	5,600
2XLF	5.6	40	80	6	9,000
2LF	5.7	30	69	6	5,600
2XLF	5.7	40	80	6	9,000
2LF	5.8	30	69	6	5,600
2XLF	5.8	40	80	6	9,000
2LF	5.9	30	69	6	5,600
2XLF	5.9	40	80	6	9,000
2LF	6	30	69	6	4,400
2XLF	6	40	80	6	5,600
2XLF	6	50	90	6	6,700
2XLF	6	60	100	6	7,100
2LF	6.1	30	69	6	6,600
2XLF	6.1	40	80	6	10,400
2LF	6.2	30	69	8	6,600
2XLF	6.2	40	80	8	10,400
2LF	6.3	30	69	8	6,600
2XLF	6.3	40	80	8	10,400
2LF	6.4	30	69	8	6,600
2XLF	6.4	40	80	8	10,400
2LF	6.5	30	69	8	6,600
2XLF	6.5	40	80	8	7,200
2XLF	6.5	50	90	8	8,400
2XLF	6.5	60	100	8	8,500
2LF	6.6	30	69	8	6,600
2XLF	6.6	40	80	8	10,400
2LF	6.7	30	69	8	6,600
2XLF	6.7	40	80	8	10,400
2LF	6.8	30	69	8	6,600
2XLF	6.8	40	80	8	10,400
2LF	6.9	30	69	8	6,600
2XLF	6.9	40	80	8	10,400
2LF	7	30	69	8	5,400
2XLF	7	40	80	8	5,600
2XLF	7	50	90	8	6,700
2XLF	7	60	100	8	7,100
2LF	7.1	30	69	8	6,600
2XLF	7.1	40	80	8	10,400
2LF	7.2	30	69	8	6,600
2XLF	7.2	40	80	8	10,400

型番	刃径 (D)	刃長 (l)	全長 (L)	シャンク径 (d)	標準価格
2LF	7.3	30	69	8	6,600
2XLF	7.3	40	80	8	10,400
2LF	7.4	30	69	8	6,600
2XLF	7.4	40	80	8	10,400
2XLF	7.5	30	70	8	6,600
2LF	7.5	35	74	8	6,600
2XLF	7.5	40	80	8	7,200
2XLF	7.5	50	90	8	8,400
2XLF	7.5	60	100	8	8,500
2LF	7.6	35	74	8	6,600
2XLF	7.6	50	90	8	10,400
2LF	7.7	35	74	8	6,600
2XLF	7.7	50	90	8	10,400
2LF	7.8	35	74	8	6,600
2XLF	7.8	50	90	8	10,400
2LF	7.9	35	74	8	6,600
2XLF	7.9	50	90	8	10,400
2XLF	8	30	70	8	5,400
2LF	8	35	74	8	5,400
2XLF	8	40	80	8	5,600
2XLF	8	50	90	8	6,700
2XLF	8	60	100	8	7,100
2XLF	8	80	120	8	8,300
2XLF	8	100	140	8	12,200
2LF	8.1	35	74	8	7,200
2XLF	8.1	50	90	8	10,400
2LF	8.2	35	74	10	7,200
2XLF	8.2	50	90	10	10,400
2LF	8.3	35	74	10	7,200
2XLF	8.3	50	90	10	10,400
2LF	8.4	35	74	10	7,200
2XLF	8.4	50	90	10	10,400
2LF	8.5	40	79	10	7,200
2XLF	8.5	50	90	10	8,400
2XLF	8.5	60	100	10	8,500
2XLF	8.5	80	120	10	10,700
2XLF	8.5	100	140	10	15,200
2LF	8.6	40	79	10	7,200
2XLF	8.6	50	90	10	10,400
2LF	8.7	40	79	10	7,200
2XLF	8.7	50	90	10	10,400
2LF	8.8	40	79	10	7,200
2XLF	8.8	50	90	10	10,400
2LF	8.9	40	79	10	7,200
2XLF	8.9	50	90	10	10,400
2LF	9	40	79	10	5,600

# (2LF / 2XLF) 3Sエンドミル 2枚刃(ロング・特ロング刃)

SINCE 1935  
F.K.D.®

2-Flute Long & Extra Long End Mills

材質=HSS-Co  
刃数=2枚  
リード角=右捩れ30°  
刃径公差=0~-0.03

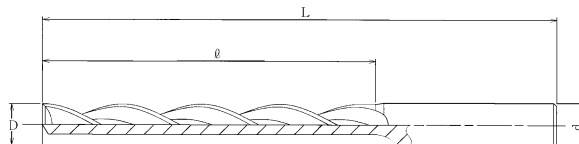

●注文例=型番、刃径、刃長、数量 「2LF 11.4x45」 ※φ40径以上のサイズはシャンク径もご指定下さい。

型番	刃径 (D)	刃長 (l)	全長 (L)	シャンク径 (d)	標準価格
2XLF	9	50	90	10	6,700
2XLF	9	60	100	10	7,100
2XLF	9	80	120	10	8,300
2XLF	9	100	140	10	12,200
2LF	9.1	40	79	10	7,200
2XLF	9.1	50	90	10	10,800
2LF	9.2	40	79	10	7,200
2XLF	9.2	50	90	10	10,800
2LF	9.3	40	79	10	7,200
2XLF	9.3	50	90	10	10,800
2LF	9.4	40	79	10	7,200
2XLF	9.4	50	90	10	10,800
2LF	9.5	40	79	10	7,200
2XLF	9.5	50	90	10	8,400
2XLF	9.5	60	100	10	8,500
2XLF	9.5	80	120	10	10,700
2XLF	9.5	100	140	10	15,200
2LF	9.6	40	79	10	7,200
2XLF	9.6	50	90	10	10,800
2LF	9.7	40	79	10	7,200
2XLF	9.7	50	90	10	10,800
2LF	9.8	40	79	10	7,200
2XLF	9.8	50	90	10	10,800
2LF	9.9	40	79	10	7,200
2XLF	9.9	50	90	10	10,800
2LF	10	40	79	10	5,600
2XLF	10	50	90	10	6,700
2XLF	10	60	100	10	7,100
2XLF	10	80	120	10	8,300
2XLF	10	100	140	10	12,200
2XLF	10	120	185	10	27,000
2LF	10.1	40	79	10	7,900
2XLF	10.1	50	90	10	12,900
2LF	10.2	40	79	12	7,900
2XLF	10.2	50	90	12	12,900
2LF	10.3	40	79	12	7,900
2XLF	10.3	50	90	12	12,900
2LF	10.4	40	79	12	7,900
2XLF	10.4	50	90	12	12,900
2XLF	10.5	40	85	12	7,800
2LF	10.5	45	91	12	7,900
2XLF	10.5	50	100	12	7,900
2XLF	10.5	60	105	12	10,300
2XLF	10.5	80	125	12	10,900
2XLF	10.5	100	145	12	15,200
2XLF	10.5	120	185	12	31,700

型番	刃径 (D)	刃長 (l)	全長 (L)	シャンク径 (d)	標準価格
2LF	10.6	45	91	12	7,900
2XLF	10.6	60	105	12	12,900
2LF	10.7	45	91	12	7,900
2XLF	10.7	60	105	12	12,900
2LF	10.8	45	91	12	7,900
2XLF	10.8	60	105	12	12,900
2LF	10.9	45	91	12	7,900
2XLF	10.9	60	105	12	12,900
2XLF	11	40	85	12	6,500
2LF	11	45	91	12	6,600
2XLF	11	50	100	12	6,600
2XLF	11	60	105	12	8,500
2XLF	11	80	125	12	8,700
2XLF	11	100	145	12	11,900
2XLF	11	120	185	12	25,300
2LF	11.1	45	91	12	7,900
2XLF	11.1	60	105	12	14,200
2LF	11.2	45	91	12	7,900
2XLF	11.2	60	105	12	14,200
2LF	11.3	45	91	12	7,900
2XLF	11.3	60	105	12	14,200
2LF	11.4	45	91	12	7,900
2XLF	11.4	60	105	12	14,200
2LF	11.5	45	91	12	7,900
2XLF	11.5	50	100	12	7,900
2XLF	11.5	60	105	12	10,300
2XLF	11.5	80	125	12	10,900
2XLF	11.5	100	145	12	15,200
2LF	11.6	45	91	12	7,900
2XLF	11.6	60	105	12	14,200
2LF	11.7	45	91	12	7,900
2XLF	11.7	60	105	12	14,200
2LF	11.8	45	91	12	7,900
2XLF	11.8	60	105	12	14,200
2LF	11.9	45	91	12	7,900
2XLF	11.9	60	105	12	14,200
2LF	12	45	91	12	6,600
2XLF	12	50	100	12	6,600
2XLF	12	60	105	12	8,500
2XLF	12	80	125	12	8,700
2XLF	12	100	145	12	11,900
2XLF	12	120	185	12	25,300
2LF	12.1	45	91	12	10,700
2XLF	12.1	60	105	12	14,200
2LF	12.2	45	91	12	10,700
2XLF	12.2	60	105	12	14,200

(2LF / 2XLF)  
**3Sエンドミル 2枚刃(ロング・特ロング刃)**  
 2-Flute Long & Extra Long End Mills



材質=HSS-Co  
 刃数=2枚  
 リード角=右捩れ30°  
 刃径公差=0~-0.03

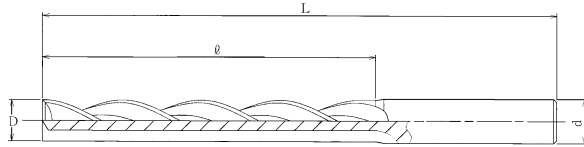

●注文例=型番、刃径、刃長、数量 「2XLF 13x80」 ※φ40径以上のサイズはシャンク径もご指定下さい。

型番	刃径 (D)	刃長 (ℓ)	全長 (L)	シャンク径 (d)	標準価格
2LF	12.3	45	91	12	10,700
2XLF	12.3	60	105	12	14,200
2LF	12.4	45	91	12	10,700
2XLF	12.4	60	105	12	14,200
2LF	12.5	50	101	12	10,700
2XLF	12.5	60	110	12	11,400
2XLF	12.5	80	130	12	13,400
2XLF	12.5	100	150	12	16,100
2XLF	12.5	120	185	12	31,700
2LF	12.6	50	101	12	10,700
2XLF	12.6	60	110	12	14,200
2LF	12.7	50	101	12	10,700
2XLF	12.7	60	110	12	14,200
2LF	12.8	50	101	12	10,700
2XLF	12.8	60	110	12	14,200
2LF	12.9	50	101	12	10,700
2XLF	12.9	60	110	12	14,200
2LF	13	50	101	12	8,600
2XLF	13	60	110	12	9,100
2XLF	13	80	130	12	10,700
2XLF	13	100	150	12	12,700
2XLF	13	120	185	12	25,300
2LF	13.1	50	101	12	10,700
2XLF	13.1	60	110	12	15,500
2LF	13.2	50	101	12	10,700
2XLF	13.2	60	110	12	15,500
2LF	13.3	50	101	12	10,700
2XLF	13.3	60	110	12	15,500
2LF	13.4	50	101	12	10,700
2XLF	13.4	60	110	12	15,500
2LF	13.5	50	101	12	10,700
2XLF	13.5	60	110	12	11,400
2XLF	13.5	80	130	12	13,400
2XLF	13.5	100	150	12	16,100
2XLF	13.5	120	185	12	31,700
2LF	13.6	50	101	12	10,700
2XLF	13.6	60	110	12	15,500
2LF	13.7	50	101	12	10,700
2XLF	13.7	60	110	12	15,500
2LF	13.8	50	101	12	10,700
2XLF	13.8	60	110	12	15,500
2LF	13.9	50	101	12	10,700
2XLF	13.9	60	110	12	15,500
2LF	14	50	101	12	8,600
2XLF	14	60	110	12	9,100
2XLF	14	70	130	12	9,900

型番	刃径 (D)	刃長 (ℓ)	全長 (L)	シャンク径 (d)	標準価格
2XLF	14	80	130	12	10,700
2XLF	14	100	150	12	12,700
2XLF	14	120	185	12	25,300
2LF	14.1	50	101	12	12,400
2XLF	14.1	70	130	12	17,700
2LF	14.2	50	101	12	12,400
2XLF	14.2	70	130	12	17,700
2LF	14.3	50	101	12	12,400
2XLF	14.3	70	130	12	17,700
2LF	14.4	50	101	12	12,400
2XLF	14.4	70	130	12	17,700
2LF	14.5	55	105	16	12,400
2XLF	14.5	70	130	16	13,400
2XLF	14.5	80	130	16	14,200
2XLF	14.5	100	150	16	18,300
2XLF	14.5	120	185	16	32,300
2LF	14.6	55	105	16	12,400
2XLF	14.6	70	130	16	17,700
2LF	14.7	55	105	16	12,400
2XLF	14.7	70	130	16	17,700
2LF	14.8	55	105	16	12,400
2XLF	14.8	70	130	16	17,700
2LF	14.9	55	105	16	12,400
2XLF	14.9	70	130	16	17,700
2LF	15	55	105	16	9,800
2XLF	15	60	110	16	10,000
2XLF	15	70	130	16	10,700
2XLF	15	80	130	16	11,200
2XLF	15	100	150	16	14,400
2XLF	15	120	185	16	25,900
2LF	15.1	55	105	16	13,600
2XLF	15.1	70	130	16	19,400
2LF	15.2	55	105	16	13,600
2XLF	15.2	70	130	16	19,400
2LF	15.3	55	105	16	13,600
2XLF	15.3	70	130	16	19,400
2LF	15.4	55	105	16	13,600
2XLF	15.4	70	130	16	19,400
2LF	15.5	55	105	16	13,600
2XLF	15.5	70	130	16	15,000
2XLF	15.5	80	130	16	15,500
2XLF	15.5	100	150	16	19,700
2XLF	15.5	120	185	16	32,300
2LF	15.6	55	105	16	13,600
2XLF	15.6	70	130	16	19,400
2LF	15.7	55	105	16	13,600

(2LF / 2XLF)  
**3Sエンドミル 2枚刃(ロング・特ロング刃)**  
 2-Flute Long & Extra Long End Mills



材質=HSS-Co  
 刃数=2枚  
 リード角=右捩れ30°  
 刃径公差=0~-0.03

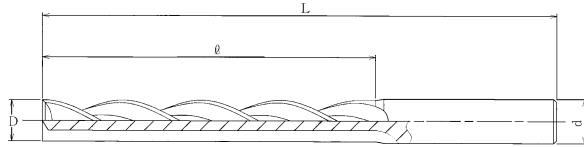

●注文例=型番、刃径、刃長、数量 「2XLF 16.5x80」 ※φ40径以上のサイズはシャンク径もご指定下さい。

型番	刃径 (D)	刃長 (ℓ)	全長 (L)	シャンク径 (d)	標準価格
2XLF	15.7	70	130	16	19,400
2LF	15.8	55	105	16	13,600
2XLF	15.8	70	130	16	19,400
2LF	15.9	55	105	16	13,600
2XLF	15.9	70	130	16	19,400
2LF	16	55	105	16	10,900
2XLF	16	60	110	16	10,900
2XLF	16	70	130	16	11,700
2XLF	16	80	130	16	12,400
2XLF	16	100	150	16	16,100
2XLF	16	120	185	16	25,900
2XLF	16	150	215	16	31,900
2LF	16.1	55	105	16	16,300
2XLF	16.1	70	130	16	23,400
2LF	16.2	55	105	16	16,300
2XLF	16.2	70	130	16	23,400
2LF	16.3	55	105	16	16,300
2XLF	16.3	70	130	16	23,400
2LF	16.4	55	105	16	16,300
2XLF	16.4	70	130	16	23,400
2LF	16.5	60	115	16	16,300
2XLF	16.5	80	135	16	18,700
2XLF	16.5	100	155	16	23,500
2XLF	16.5	120	185	16	32,300
2LF	16.6	60	115	16	16,300
2XLF	16.6	80	135	16	23,400
2LF	16.7	60	115	16	16,300
2XLF	16.7	80	135	16	23,400
2LF	16.8	60	115	16	16,300
2XLF	16.8	80	135	16	23,400
2LF	16.9	60	115	16	16,300
2XLF	16.9	80	135	16	23,400
2LF	17	60	115	16	12,900
2XLF	17	80	135	16	15,000
2XLF	17	100	155	16	18,700
2XLF	17	120	185	16	25,900
2XLF	17	150	215	16	31,900
2LF	17.1	60	115	16	16,300
2XLF	17.1	80	135	16	23,800
2LF	17.2	60	115	16	16,300
2XLF	17.2	80	135	16	23,800
2LF	17.3	60	115	16	16,300
2XLF	17.3	80	135	16	23,800
2LF	17.4	60	115	16	16,300
2XLF	17.4	80	135	16	23,800
2LF	17.5	60	115	16	16,300

型番	刃径 (D)	刃長 (ℓ)	全長 (L)	シャンク径 (d)	標準価格
2XLF	17.5	80	135	16	18,700
2XLF	17.5	100	155	16	23,500
2XLF	17.5	120	185	16	32,300
2LF	17.6	60	115	16	16,300
2XLF	17.6	80	135	16	23,800
2LF	17.7	60	115	16	16,300
2XLF	17.7	80	135	16	23,800
2LF	17.8	60	115	16	16,300
2XLF	17.8	80	135	16	23,800
2LF	17.9	60	115	16	16,300
2XLF	17.9	80	135	16	23,800
2LF	18	60	115	16	12,900
2XLF	18	80	135	16	15,000
2XLF	18	100	155	16	18,700
2XLF	18	120	185	16	25,900
2XLF	18	150	215	16	31,900
2LF	18.1	60	115	16	19,100
2XLF	18.1	80	135	16	23,800
2LF	18.2	60	115	16	19,100
2XLF	18.2	80	135	16	23,800
2LF	18.3	60	115	16	19,100
2XLF	18.3	80	135	16	23,800
2LF	18.4	60	115	16	19,100
2XLF	18.4	80	135	16	23,800
2XLF	18.5	60	125	20	19,100
2LF	18.5	65	130	20	19,100
2XLF	18.5	80	145	20	19,100
2XLF	18.5	100	165	20	27,100
2XLF	18.5	120	185	20	33,000
2LF	18.6	65	130	20	19,100
2XLF	18.6	80	145	20	23,800
2LF	18.7	65	130	20	19,100
2XLF	18.7	80	145	20	23,800
2LF	18.8	65	130	20	19,100
2XLF	18.8	80	145	20	23,800
2LF	18.9	65	130	20	19,100
2XLF	18.9	80	145	20	23,800
2LF	19	65	130	20	15,200
2XLF	19	80	145	20	15,200
2XLF	19	100	165	20	21,700
2XLF	19	120	185	20	26,400
2XLF	19	150	215	20	31,900
2LF	19.1	65	130	20	19,100
2XLF	19.1	80	145	20	30,400
2LF	19.2	65	130	20	19,100
2XLF	19.2	80	145	20	30,400

(2LF / 2XLF)  
**3Sエンドミル 2枚刃(ロング・特ロング刃)**  
 2-Flute Long & Extra Long End Mills



材質=HSS-Co  
 刃数=2枚  
 リード角=右捩れ30°  
 刃径公差=0~-0.03

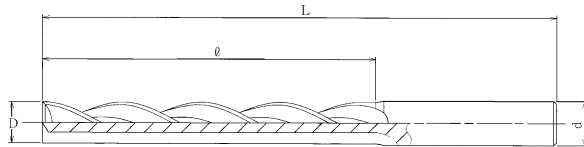

●注文例=型番、刃径、刃長、数量 「2XLF 22.5x120」 ※φ40径以上のサイズはシャンク径もご指定下さい。

型番	刃径 (D)	刃長 (ℓ)	全長 (L)	シャンク径 (d)	標準価格
2LF	19.3	65	130	20	19,100
2XLF	19.3	80	145	20	30,400
2LF	19.4	65	130	20	19,100
2XLF	19.4	80	145	20	30,400
2LF	19.5	65	130	20	19,100
2XLF	19.5	80	145	20	19,100
2XLF	19.5	100	165	20	27,100
2XLF	19.5	120	185	20	33,000
2XLF	19.5	150	215	20	39,700
2LF	19.6	65	130	20	19,100
2XLF	19.6	80	145	20	30,400
2LF	19.7	65	130	20	19,100
2XLF	19.7	80	145	20	30,400
2LF	19.8	65	130	20	19,100
2XLF	19.8	80	145	20	30,400
2LF	19.9	65	130	20	19,100
2XLF	19.9	80	145	20	30,400
2LF	20	65	130	20	15,200
2XLF	20	80	145	20	15,200
2XLF	20	100	165	20	21,700
2XLF	20	120	185	20	26,400
2XLF	20	150	215	20	31,900
2XLF	20	180	245	20	42,800
2XLF	20	200	270	20	50,100
2LF	20.1	65	130	20	23,100
2LF	20.2	65	130	20	23,100
2LF	20.3	65	130	20	23,100
2LF	20.4	65	130	20	23,100
2LF	20.5	70	135	20	23,100
2XLF	20.5	80	145	20	25,100
2XLF	20.5	100	165	20	30,600
2XLF	20.5	120	185	20	37,100
2XLF	20.5	150	215	20	47,200
2LF	20.6	70	135	20	23,100
2LF	20.7	70	135	20	23,100
2LF	20.8	70	135	20	23,100
2LF	20.9	70	135	20	23,100
2LF	21	70	135	20	18,700
2XLF	21	80	145	20	20,100
2XLF	21	100	165	20	24,400
2XLF	21	120	185	20	29,800
2XLF	21	150	215	20	37,800
2XLF	21	180	245	20	45,400
2XLF	21	200	270	20	59,200
2LF	21.5	70	135	20	23,100
2XLF	21.5	80	145	20	25,100

型番	刃径 (D)	刃長 (ℓ)	全長 (L)	シャンク径 (d)	標準価格
2XLF	21.5	100	165	20	30,600
2XLF	21.5	120	185	20	37,100
2XLF	21.5	150	215	20	47,200
2LF	22	70	135	20	18,700
2XLF	22	80	145	20	20,100
2XLF	22	100	165	20	24,400
2XLF	22	120	185	20	29,800
2XLF	22	150	215	20	37,800
2XLF	22	180	245	20	47,300
2XLF	22	200	270	20	59,200
2LF	22.5	75	145	25	28,200
2XLF	22.5	80	150	25	29,300
2XLF	22.5	100	170	25	33,900
2XLF	22.5	120	190	25	41,800
2XLF	22.5	150	220	25	49,200
2XLF	22.5	200	270	25	74,000
2LF	23	75	145	25	22,600
2XLF	23	80	150	25	23,300
2XLF	23	100	170	25	27,000
2XLF	23	120	190	25	33,700
2XLF	23	150	220	25	39,400
2XLF	23	180	250	25	49,200
2XLF	23	200	270	25	59,200
2LF	23.5	75	145	25	28,200
2XLF	23.5	80	150	25	29,300
2XLF	23.5	100	170	25	33,900
2XLF	23.5	120	190	25	41,800
2XLF	23.5	150	220	25	49,200
2LF	24	75	145	25	22,600
2XLF	24	80	150	25	23,300
2XLF	24	100	170	25	27,000
2XLF	24	120	190	25	33,700
2XLF	24	150	220	25	39,400
2XLF	24	180	250	25	51,700
2XLF	24	200	270	25	59,200
2LF	24.5	80	150	25	30,100
2XLF	24.5	100	170	25	33,900
2XLF	24.5	120	190	25	44,800
2XLF	24.5	150	220	25	49,200
2LF	25	80	150	25	24,100
2XLF	25	100	170	25	27,000
2XLF	25	120	190	25	35,800
2XLF	25	150	220	25	39,400
2XLF	25	180	250	25	54,200
2XLF	25	200	270	25	60,200
2LF	25.5	80	150	25	30,100

# (2LF / 2XLF) 3Sエンドミル 2枚刃(ロング・特ロング刃)

SINCE 1935  
F.K.D.®

2-Flute Long & Extra Long End Mills

材質=HSS-Co  
刃数=2枚  
リード角=右捩れ30°  
刃径公差=0~-0.03

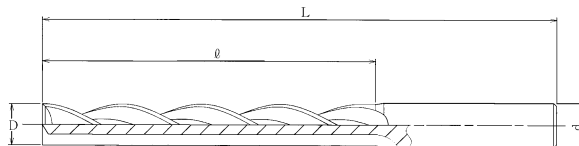

●注文例=型番、刃径、刃長、数量「2LF 32x90」 ※φ40径以上のサイズはシャンク径もご指定下さい。

型番	刃径 (D)	刃長 (l)	全長 (L)	シャンク径 (d)	標準価格
2XLF	25.5	100	170	25	37,100
2XLF	25.5	120	190	25	50,500
2XLF	25.5	150	220	25	58,200
2LF	26	80	150	25	24,100
2XLF	26	100	170	25	29,800
2XLF	26	120	190	25	40,400
2XLF	26	150	220	25	46,600
2XLF	26	180	250	25	58,500
2XLF	26	200	270	25	61,500
2LF	26.5	85	155	25	38,700
2XLF	26.5	100	170	25	38,700
2XLF	26.5	120	190	25	56,400
2XLF	26.5	150	220	25	64,000
2LF	27	85	155	25	30,900
2XLF	27	100	170	25	30,900
2XLF	27	120	190	25	45,400
2XLF	27	150	220	25	51,400
2XLF	27	180	250	25	65,000
2XLF	27	200	270	25	77,300
2LF	27.5	85	155	25	38,700
2XLF	27.5	100	170	25	38,700
2XLF	27.5	120	190	25	56,400
2XLF	27.5	150	220	25	64,000
2LF	28	85	155	25	30,900
2XLF	28	100	170	25	30,900
2XLF	28	120	190	25	45,400
2XLF	28	150	220	25	51,400
2XLF	28	180	250	25	69,700
2XLF	28	200	270	25	77,300
2LF	28.5	90	160	25	46,300
2XLF	28.5	100	170	25	49,200
2XLF	28.5	120	190	25	66,600
2XLF	28.5	150	220	25	72,600
2LF	29	90	160	25	37,000
2XLF	29	100	170	25	39,400
2XLF	29	120	190	25	53,100
2XLF	29	150	220	25	58,100
2XLF	29	180	250	25	77,900
2XLF	29	200	270	25	94,200
2LF	29.5	90	160	25	46,300
2XLF	29.5	100	170	25	49,200
2XLF	29.5	120	190	25	66,600
2XLF	29.5	150	220	25	72,600
2LF	30	90	160	25	37,000
2XLF	30	100	170	25	39,400
2XLF	30	120	190	25	53,100

型番	刃径 (D)	刃長 (l)	全長 (L)	シャンク径 (d)	標準価格
2XLF	30	150	220	25	58,100
2XLF	30	180	250	25	82,400
2XLF	30	200	270	25	94,200
2LF	30.5	90	160	32	55,600
2XLF	30.5	100	170	32	58,000
2LF	31	90	160	32	44,400
2XLF	31	100	170	32	46,300
2XLF	31	120	190	32	58,100
2XLF	31	150	220	32	64,700
2LF	31.5	90	160	32	55,600
2LF	32	90	160	32	44,400
2XLF	32	100	170	32	46,300
2XLF	32	120	190	32	58,100
2XLF	32	150	220	32	64,700
2XLF	32	180	250	32	87,500
2XLF	32	200	270	32	96,300
2LF	33	95	175	32	55,600
2XLF	33	100	180	32	56,400
2XLF	33	120	200	32	67,800
2XLF	33	150	230	32	75,400
2LF	34	95	175	32	55,600
2XLF	34	100	180	32	56,400
2XLF	34	120	200	32	67,800
2XLF	34	150	230	32	75,400
2XLF	34	200	280	32	118,900
2LF	35	95	175	32	56,400
2XLF	35	100	180	32	56,400
2XLF	35	120	200	32	71,000
2XLF	35	150	230	32	78,500
2XLF	35	180	260	32	106,900
2XLF	35	200	280	32	118,900
2XLF	35	250	350	32	143,400
2LF	36	95	175	32	60,800
2XLF	36	100	180	32	60,000
2XLF	36	120	200	32	74,000
2XLF	36	150	230	32	85,500
2XLF	36	200	280	32	124,700
2LF	37	100	180	32	68,400
2XLF	37	120	200	32	81,100
2XLF	37	150	230	32	91,900
2XLF	37	200	280	32	129,900
2LF	38	100	180	32	68,400
2XLF	38	120	200	32	81,100
2XLF	38	150	230	32	91,900
2XLF	38	200	280	32	129,900
2LF	39	100	180	32	77,700



# (2LF / 2XLF) 3Sエンドミル 2枚刃(ロング・特ロング刃)

2-Flute Long & Extra Long End Mills



材質=HSS-Co  
刃数=2枚  
リード角=右捩れ30°  
刃径公差=0~-0.03

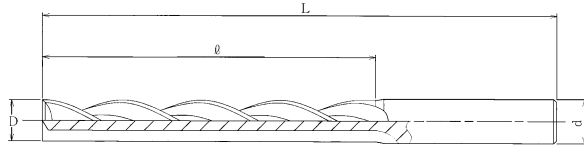

●注文例=型番、刃径、刃長、シャンク径、数量「2XLF 45x200x42」

※φ40径以上のサイズはシャンク径もご指定下さい。

型番	刃径 (D)	刃長 (ℓ)	全長 (L)	シャンク径 (d)	標準価格
2XLF	39	120	200	32	88,800
2XLF	39	150	230	32	102,500
2XLF	39	200	280	32	139,000
2LF	40	100	180	32	77,700
2LF	40	100	195	42	81,100
2XLF	40	120	200	32	88,800
2XLF	40	120	215	42	92,500
2XLF	40	150	230	32	102,500
2XLF	40	150	245	42	106,900
2XLF	40	180	260	32	131,200
2XLF	40	180	275	42	136,600
2XLF	40	200	280	32	139,000
2XLF	40	200	295	42	145,100
2XLF	40	250	350	32	174,400
2XLF	40	250	350	42	181,500
2LF	41	110	195	32	81,300
2XLF	41	120	205	32	94,400
2XLF	41	120	215	42	98,100
2XLF	41	150	235	32	114,400
2XLF	41	150	245	42	119,200
2XLF	41	200	285	32	145,100
2XLF	41	200	295	42	150,900
2LF	42	110	195	32	81,300
2LF	42	110	205	42	84,800
2XLF	42	120	205	32	94,400
2XLF	42	120	215	42	98,100
2XLF	42	150	235	32	114,400
2XLF	42	150	245	42	119,200
2XLF	42	180	265	32	141,100
2XLF	42	200	285	32	145,100
2XLF	42	200	295	42	150,900
2LF	43	110	195	32	89,900
2XLF	43	120	205	32	97,600
2XLF	43	120	215	42	101,500
2XLF	43	150	235	32	119,700
2XLF	43	150	245	42	124,700
2XLF	43	200	285	32	173,500
2XLF	43	200	295	42	180,700
2LF	44	110	195	32	89,900
2XLF	44	120	205	32	100,100
2XLF	44	120	215	42	104,500
2XLF	44	150	235	32	119,700
2XLF	44	150	245	42	124,700
2XLF	44	200	285	32	173,500
2XLF	44	200	295	42	180,700
2LF	45	120	205	32	96,100

型番	刃径 (D)	刃長 (ℓ)	全長 (L)	シャンク径 (d)	標準価格
2LF	45	120	215	42	100,100
2XLF	45	150	235	32	119,700
2XLF	45	150	245	42	124,700
2XLF	45	180	265	32	159,700
2XLF	45	200	285	32	175,500
2XLF	45	200	295	42	182,900
2XLF	45	250	350	32	222,000
2XLF	45	250	350	42	231,100
2LF	46	120	205	32	96,100
2XLF	46	150	235	32	145,200
2XLF	46	150	245	42	151,300
2XLF	46	200	285	32	180,500
2XLF	46	200	295	42	188,000
2LF	47	120	205	32	105,900
2XLF	47	150	235	32	145,200
2XLF	47	150	245	42	151,300
2XLF	47	200	285	32	185,500
2XLF	47	200	295	42	193,300
2LF	48	120	205	32	105,900
2XLF	48	150	235	32	145,200
2XLF	48	150	245	42	151,300
2XLF	48	180	265	32	180,000
2XLF	48	200	285	32	185,500
2XLF	48	200	295	42	193,300
2LF	49	120	205	32	130,100
2XLF	49	150	235	32	153,200
2XLF	49	150	245	42	159,600
2XLF	49	200	285	32	208,500
2XLF	49	200	295	42	217,300
2LF	50	120	205	32	130,100
2LF	50	120	215	42	135,700
2XLF	50	150	235	32	153,200
2XLF	50	150	245	42	159,600
2XLF	50	180	265	32	196,200
2XLF	50	200	285	32	208,500
2XLF	50	200	295	42	217,300
2XLF	50	250	350	32	271,700
2XLF	50	250	350	42	283,000
2XLF	50	300	400	42	319,000
2XLF	55	150	235	32	191,200
2XLF	55	150	245	42	199,500
2XLF	55	200	285	32	256,200
2XLF	55	200	295	42	266,800
2XLF	55	250	350	32	312,500
2XLF	55	250	350	42	325,500
2XLF	55	300	400	42	368,300

(2LF / 2XLF)  
**3Sエンドミル 2枚刃(ロング・特ロング刃)**  
 2-Flute Long & Extra Long End Mills



材質=HSS-Co  
 刃数=2枚  
 リード角=右振り30°  
 刃径公差=0~-0.03

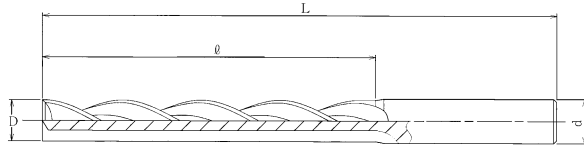

●注文例=型番、刃径、刃長、シャンク径、数量「2XLF 60x200x32」

※φ40径以上のサイズはシャンク径もご指定下さい。

型番	刃径 (D)	刃長 (l)	全長 (L)	シャンク径 (d)	標準価格
2XLF	60	150	235	32	220,400
2XLF	60	150	245	42	229,900
2XLF	60	200	285	32	293,800
2XLF	60	200	295	42	306,100
2XLF	60	250	350	32	358,600
2XLF	60	250	350	42	373,600
2XLF	60	300	400	42	421,900

(LS-2LF)  
 ロングシャンクエンドミル 2枚刃  
 2-Flute Long Shank End Mills

SINCE 1935  
 F.K.D.®

材質=HSS-Co  
 刃数=2枚  
 リード角=右振り30°  
 刃径公差=0~-0.03

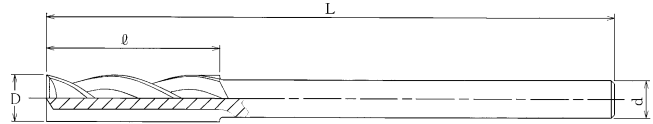

●注文例=型番、刃径、数量 「LS-2LF 3」

型番	刃径 (D)	刃長 (ℓ)	全長 (L)	シャンク径 (d)	標準価格
LS-2LF	3	30	100	6	6,500
LS-2LF	3.5	30	100	6	8,200
LS-2LF	4	30	100	6	6,500
LS-2LF	4.5	30	100	6	8,200
LS-2LF	5	30	100	6	6,500
LS-2LF	5.5	30	100	6	8,200
LS-2LF	6	30	120	6	6,500
LS-2LF	6.5	30	120	6	8,200
LS-2LF	7	30	120	6	6,500
LS-2LF	7.5	35	120	6	9,200
LS-2LF	8	35	120	8	7,400
LS-2LF	8.5	40	120	8	9,200
LS-2LF	9	40	120	8	7,400
LS-2LF	9.5	40	150	8	10,000
LS-2LF	10	40	150	10	8,000
LS-2LF	10.5	45	150	10	11,700
LS-2LF	11	45	150	10	9,400
LS-2LF	11.5	45	150	10	11,700
LS-2LF	12	45	150	12	9,400
LS-2LF	12.5	50	150	12	14,900
LS-2LF	13	50	150	12	11,800
LS-2LF	13.5	50	150	12	14,900
LS-2LF	14	50	150	12	11,800
LS-2LF	14.5	55	180	12	17,700
LS-2LF	15	55	180	12	14,200
LS-2LF	15.5	55	180	12	19,700
LS-2LF	16	55	180	16	15,500
LS-2LF	16.5	60	180	16	22,700
LS-2LF	17	60	180	16	18,300

型番	刃径 (D)	刃長 (ℓ)	全長 (L)	シャンク径 (d)	標準価格
LS-2LF	17.5	60	180	16	22,700
LS-2LF	18	60	180	16	18,300
LS-2LF	18.5	65	200	16	26,400
LS-2LF	19	65	200	16	21,300
LS-2LF	19.5	65	200	16	26,400
LS-2LF	20	65	200	20	21,300
LS-2LF	21	70	200	20	25,500
LS-2LF	22	70	200	20	25,500
LS-2LF	23	75	250	20	31,400
LS-2LF	24	75	250	20	31,400
LS-2LF	25	80	250	25	32,900
LS-2LF	26	80	250	25	36,700
LS-2LF	27	85	250	25	42,700
LS-2LF	28	85	250	25	42,700
LS-2LF	29	100	250	25	51,500
LS-2LF	30	100	250	25	51,500
LS-2LF	32	100	300	32	59,200
LS-2LF	33	100	300	32	72,500
LS-2LF	34	100	300	32	72,500
LS-2LF	35	100	300	32	72,500
LS-2LF	36	100	300	32	80,700
LS-2LF	38	100	300	32	88,600
LS-2LF	40	100	300	32	99,600
LS-2LF	42	100	300	32	99,600
LS-2LF	44	100	300	32	133,200
LS-2LF	45	120	300	42	138,900
LS-2LF	46	120	300	42	138,900
LS-2LF	48	120	300	42	173,600
LS-2LF	50	120	300	42	173,600

(XLS-2SF)  
**特ロングシャンクエンドミル 2枚刃**  
 2-Flute Extra Long Shank End Mills

SINCE 1935  
**F.K.D.**®

材質=HSS-Co  
 刃数=2枚  
 リード角=右捩れ30°  
 刃径公差=0~-0.03

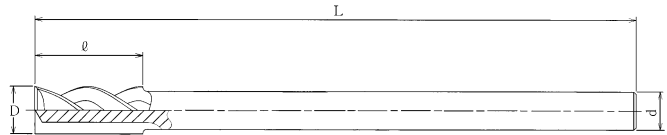

●注文例=型番、刃径、全長、数量「XLS-2SF 8x100」 ※φ45径以上のサイズはシャンク径もご指定下さい。

型番	刃径 (D)	刃長 (ℓ)	全長 (L)	シャンク径 (d)	標準価格
XLS-2SF	8	20	100	6	7,400
XLS-2SF	8	20	150	6	9,500
XLS-2SF	8.5	25	100	8	9,800
XLS-2SF	8.5	25	150	8	11,300
XLS-2SF	9	25	100	8	8,200
XLS-2SF	9	25	150	8	9,500
XLS-2SF	9.5	25	100	8	9,800
XLS-2SF	9.5	25	150	8	11,300
XLS-2SF	10	25	100	8	8,200
XLS-2SF	10	25	150	8	9,500
XLS-2SF	10.5	30	150	10	12,400
XLS-2SF	10.5	30	200	10	14,200
XLS-2SF	11	30	150	10	10,200
XLS-2SF	11	30	200	10	11,800
XLS-2SF	11.5	30	150	10	12,400
XLS-2SF	11.5	30	200	10	14,200
XLS-2SF	12	30	150	10	10,200
XLS-2SF	12	30	200	10	11,800
XLS-2SF	12.5	35	150	12	13,500
XLS-2SF	12.5	35	200	12	17,400
XLS-2SF	13	35	150	12	11,400
XLS-2SF	13	35	200	12	14,400
XLS-2SF	13.5	35	150	12	13,500
XLS-2SF	13.5	35	200	12	17,400
XLS-2SF	14	35	150	12	11,400
XLS-2SF	14	35	200	12	14,400
XLS-2SF	14.5	40	150	12	14,200
XLS-2SF	14.5	40	200	12	19,400
XLS-2SF	15	40	150	12	11,800
XLS-2SF	15	40	200	12	16,200
XLS-2SF	15.5	40	150	12	16,200
XLS-2SF	15.5	40	200	12	21,700
XLS-2SF	16	40	150	12	13,400
XLS-2SF	16	40	200	12	18,300
XLS-2SF	16.5	40	200	16	25,100
XLS-2SF	16.5	40	250	16	26,400
XLS-2SF	17	40	200	16	21,000
XLS-2SF	17	40	250	16	22,000
XLS-2SF	17.5	40	200	16	25,100
XLS-2SF	17.5	40	250	16	26,400
XLS-2SF	18	40	200	16	21,000
XLS-2SF	18	40	250	16	22,000
XLS-2SF	18.5	45	200	16	28,200
XLS-2SF	18.5	45	250	16	30,600
XLS-2SF	19	45	200	16	23,500
XLS-2SF	19	45	250	16	25,300
XLS-2SF	19.5	45	200	16	28,200
XLS-2SF	19.5	45	250	16	31,200
XLS-2SF	20	45	200	16	23,500
XLS-2SF	20	45	250	16	26,100

型番	刃径 (D)	刃長 (ℓ)	全長 (L)	シャンク径 (d)	標準価格
XLS-2SF	21	45	250	20	30,100
XLS-2SF	21	45	300	20	30,900
XLS-2SF	22	45	250	20	30,100
XLS-2SF	22	45	300	20	30,900
XLS-2SF	23	50	250	20	34,900
XLS-2SF	23	50	300	20	38,500
XLS-2SF	24	50	250	20	34,900
XLS-2SF	24	50	300	20	38,500
XLS-2SF	25	50	250	20	34,900
XLS-2SF	25	50	300	20	38,500
XLS-2SF	26	50	250	25	37,000
XLS-2SF	26	50	300	25	43,800
XLS-2SF	27	55	250	25	47,300
XLS-2SF	27	55	300	25	50,100
XLS-2SF	28	55	250	25	47,300
XLS-2SF	28	55	300	25	50,100
XLS-2SF	29	55	250	25	47,900
XLS-2SF	29	55	300	25	56,800
XLS-2SF	30	55	250	25	47,900
XLS-2SF	30	55	300	25	56,800
XLS-2SF	31	60	250	25	59,500
XLS-2SF	31	60	300	25	61,500
XLS-2SF	32	60	250	25	59,500
XLS-2SF	32	60	300	25	61,500
XLS-2SF	33	60	250	32	68,400
XLS-2SF	33	60	350	32	73,400
XLS-2SF	34	60	250	32	68,400
XLS-2SF	34	60	350	32	73,400
XLS-2SF	35	60	250	32	71,900
XLS-2SF	35	60	350	32	73,400
XLS-2SF	36	65	250	32	75,800
XLS-2SF	36	65	350	32	83,400
XLS-2SF	37	65	250	32	88,800
XLS-2SF	37	65	350	32	92,200
XLS-2SF	38	65	250	32	88,800
XLS-2SF	38	65	350	32	92,200
XLS-2SF	39	65	250	32	92,200
XLS-2SF	39	65	350	32	99,000
XLS-2SF	40	65	250	32	92,200
XLS-2SF	40	65	350	32	99,000
XLS-2SF	42	70	300	32	99,000
XLS-2SF	42	70	350	32	112,800
XLS-2SF	45	70	300	32	102,500
XLS-2SF	45	70	350	32	136,600
XLS-2SF	45	70	300	42	106,900
XLS-2SF	45	70	350	42	142,500
XLS-2SF	50	75	300	32	133,100
XLS-2SF	50	75	350	32	150,300
XLS-2SF	50	75	300	42	138,800
XLS-2SF	50	75	350	42	156,500

# (V-2SF) Vコート3Sエンドミル 2枚刃

2-Flute V-coat Standard End Mills

材質=粉末ハイス  
刃数=2枚  
リード角=右捩れ3°  
刃径公差=0~-0.03(D≤20)  
0~-0.04(D>20)

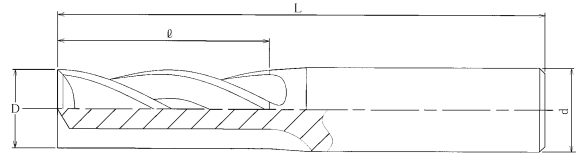
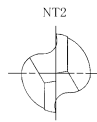

●注文例=型番、刃径、数量 「V-2SF 0.8」

型番	刃径 (D)	刃長 (ℓ)	全長 (L)	シャンク径 (d)	標準価格
V-2SF	0.5	1	50	6	17,200
V-2SF	0.6	1.2	50	6	13,900
V-2SF	0.7	1.4	50	6	13,900
V-2SF	0.8	1.6	50	6	11,600
V-2SF	0.9	2	50	6	11,600
V-2SF	1	3	50	6	8,900
V-2SF	1.1	3	50	6	11,600
V-2SF	1.2	3	50	6	11,600
V-2SF	1.3	3	50	6	11,600
V-2SF	1.4	3	50	6	11,600
V-2SF	1.5	4.5	50	6	8,200
V-2SF	1.6	4.5	50	6	10,600
V-2SF	1.7	4.5	50	6	10,600
V-2SF	1.8	4.5	50	6	10,600
V-2SF	1.9	4.5	50	6	10,600
V-2SF	2	6	50	6	7,700
V-2SF	2.1	6	50	6	10,100
V-2SF	2.2	6	50	6	10,100
V-2SF	2.3	6	50	6	10,100
V-2SF	2.4	8	50	6	10,100
V-2SF	2.5	8	50	6	7,700
V-2SF	2.6	8	50	6	9,900
V-2SF	2.7	8	50	6	9,900
V-2SF	2.8	8	50	6	9,900
V-2SF	2.9	8	50	6	9,900
V-2SF	3	10	50	6	6,200
V-2SF	3.1	10	50	6	8,500
V-2SF	3.2	10	50	6	8,500
V-2SF	3.3	10	50	6	8,500
V-2SF	3.4	10	50	6	8,500
V-2SF	3.5	10	60	8	6,600
V-2SF	3.6	10	60	8	8,500
V-2SF	3.7	10	60	8	8,500
V-2SF	3.8	10	60	8	8,500
V-2SF	3.9	10	60	8	8,500
V-2SF	4	12	60	8	6,200
V-2SF	4.1	12	60	8	8,500
V-2SF	4.2	12	60	8	8,500
V-2SF	4.3	12	60	8	8,500
V-2SF	4.4	12	60	8	8,500
V-2SF	4.5	12	60	8	6,600
V-2SF	4.6	12	60	8	8,500
V-2SF	4.7	12	60	8	8,500
V-2SF	4.8	12	60	8	8,500
V-2SF	4.9	12	60	8	8,500
V-2SF	5	15	60	8	6,200
V-2SF	5.1	15	60	8	8,500
V-2SF	5.2	15	60	8	8,500
V-2SF	5.3	15	60	8	8,500

型番	刃径 (D)	刃長 (ℓ)	全長 (L)	シャンク径 (d)	標準価格
V-2SF	5.4	15	60	8	8,500
V-2SF	5.5	15	60	8	6,600
V-2SF	5.6	15	60	8	8,500
V-2SF	5.7	15	60	8	8,500
V-2SF	5.8	15	60	8	8,500
V-2SF	5.9	15	60	8	8,500
V-2SF	6	15	60	8	6,200
V-2SF	6.1	15	60	8	9,300
V-2SF	6.2	15	60	8	9,300
V-2SF	6.3	15	60	8	9,300
V-2SF	6.4	15	60	8	9,300
V-2SF	6.5	15	65	10	7,100
V-2SF	6.6	15	65	10	9,300
V-2SF	6.7	15	65	10	9,300
V-2SF	6.8	15	65	10	9,300
V-2SF	6.9	15	65	10	9,300
V-2SF	7	20	65	10	7,100
V-2SF	7.1	20	65	10	9,300
V-2SF	7.2	20	65	10	9,300
V-2SF	7.3	20	65	10	9,300
V-2SF	7.4	20	65	10	9,300
V-2SF	7.5	20	65	10	7,100
V-2SF	7.6	20	65	10	9,300
V-2SF	7.7	20	65	10	9,300
V-2SF	7.8	20	65	10	9,300
V-2SF	7.9	20	65	10	9,300
V-2SF	8	20	65	10	7,100
V-2SF	8.1	20	65	10	10,700
V-2SF	8.2	20	65	10	10,700
V-2SF	8.3	20	65	10	10,700
V-2SF	8.4	20	65	10	10,700
V-2SF	8.5	20	75	10	8,200
V-2SF	8.6	20	75	10	10,700
V-2SF	8.7	20	75	10	10,700
V-2SF	8.8	20	75	10	10,700
V-2SF	8.9	20	75	10	10,700
V-2SF	9	25	75	10	7,900
V-2SF	9.1	25	75	10	10,700
V-2SF	9.2	25	75	10	10,700
V-2SF	9.3	25	75	10	10,700
V-2SF	9.4	25	75	10	10,700
V-2SF	9.5	25	75	12	9,900
V-2SF	9.6	25	75	12	10,700
V-2SF	9.7	25	75	12	10,700
V-2SF	9.8	25	75	12	10,700
V-2SF	9.9	25	75	12	10,700
V-2SF	10	25	75	10	9,900
V-2SF	10.1	25	75	12	11,000
V-2SF	10.2	25	75	12	11,000

※ 特定代理店のみの扱いです。

# (V-2SF) Vコート3Sエンドミル 2枚刃

2-Flute V-coat Standard End Mills

材質=粉末ハイス  
刃数=2枚  
リード角=右捩れ30°  
刃径公差=0~-0.03(D≤20)  
0~-0.04(D>20)

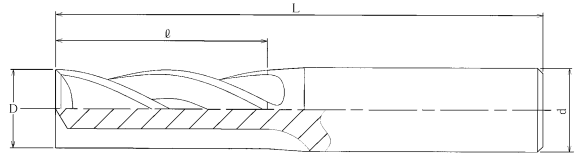
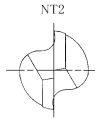

●注文例=型番、刃径、数量 「V-2SF 11.3」

型番	刃径 (D)	刃長 (ℓ)	全長 (L)	シャンク径 (d)	標準価格
V-2SF	10.3	25	75	12	11,000
V-2SF	10.4	25	75	12	11,000
V-2SF	10.5	25	75	12	9,900
V-2SF	10.6	25	75	12	11,000
V-2SF	10.7	25	75	12	11,000
V-2SF	10.8	25	75	12	11,000
V-2SF	10.9	25	75	12	11,000
V-2SF	11	30	85	12	10,100
V-2SF	11.1	30	85	12	14,200
V-2SF	11.2	30	85	12	14,200
V-2SF	11.3	30	85	12	14,200
V-2SF	11.4	30	85	12	14,200
V-2SF	11.5	30	85	12	11,000
V-2SF	11.6	30	85	12	14,200
V-2SF	11.7	30	85	12	14,200
V-2SF	11.8	30	85	12	14,200
V-2SF	11.9	30	85	12	14,200
V-2SF	12	30	85	12	10,100
V-2SF	12.1	30	85	12	14,200
V-2SF	12.2	30	85	12	14,200
V-2SF	12.3	30	85	12	14,200
V-2SF	12.4	30	85	12	14,200
V-2SF	12.5	30	85	12	11,000
V-2SF	12.6	30	85	12	14,200
V-2SF	12.7	30	85	12	14,200
V-2SF	12.8	30	85	12	14,200
V-2SF	12.9	30	85	12	14,200
V-2SF	13	35	90	12	13,400
V-2SF	13.1	35	90	12	18,900
V-2SF	13.2	35	90	12	18,900
V-2SF	13.3	35	90	12	18,900
V-2SF	13.4	35	90	12	18,900
V-2SF	13.5	35	90	16	14,500
V-2SF	13.6	35	90	16	18,900
V-2SF	13.7	35	90	16	18,900
V-2SF	13.8	35	90	16	18,900
V-2SF	13.9	35	90	16	18,900
V-2SF	14	35	90	16	14,500
V-2SF	14.1	35	90	16	18,900
V-2SF	14.2	35	90	16	18,900
V-2SF	14.3	35	90	16	18,900
V-2SF	14.4	35	90	16	18,900
V-2SF	14.5	35	90	16	14,500
V-2SF	14.6	35	90	16	18,900
V-2SF	14.7	35	90	16	18,900
V-2SF	14.8	35	90	16	18,900
V-2SF	14.9	35	90	16	18,900
V-2SF	15	40	100	16	14,900
V-2SF	15.1	40	100	16	20,900

型番	刃径 (D)	刃長 (ℓ)	全長 (L)	シャンク径 (d)	標準価格
V-2SF	15.2	40	100	16	20,900
V-2SF	15.3	40	100	16	20,900
V-2SF	15.4	40	100	16	20,900
V-2SF	15.5	40	100	16	16,100
V-2SF	15.6	40	100	16	20,900
V-2SF	15.7	40	100	16	20,900
V-2SF	15.8	40	100	16	20,900
V-2SF	15.9	40	100	16	20,900
V-2SF	16	40	100	16	16,100
V-2SF	16.1	40	100	16	22,600
V-2SF	16.2	40	100	16	22,600
V-2SF	16.3	40	100	16	22,600
V-2SF	16.4	40	100	16	22,600
V-2SF	16.5	40	100	16	17,300
V-2SF	16.6	40	100	16	22,600
V-2SF	16.7	40	100	16	22,600
V-2SF	16.8	40	100	16	22,600
V-2SF	16.9	40	100	16	22,600
V-2SF	17	40	100	16	19,000
V-2SF	17.1	40	100	16	26,900
V-2SF	17.2	40	100	16	26,900
V-2SF	17.3	40	100	16	26,900
V-2SF	17.4	40	100	16	26,900
V-2SF	17.5	40	100	16	20,700
V-2SF	17.6	40	100	16	26,900
V-2SF	17.7	40	100	16	26,900
V-2SF	17.8	40	100	16	26,900
V-2SF	17.9	40	100	16	26,900
V-2SF	18	40	100	16	19,000
V-2SF	18.1	40	100	16	26,900
V-2SF	18.2	40	100	16	26,900
V-2SF	18.3	40	100	16	26,900
V-2SF	18.4	40	100	16	26,900
V-2SF	18.5	40	100	20	22,900
V-2SF	18.6	40	100	20	26,900
V-2SF	18.7	40	100	20	26,900
V-2SF	18.8	40	100	20	26,900
V-2SF	18.9	40	100	20	26,900
V-2SF	19	45	120	20	23,900
V-2SF	19.1	45	120	20	32,500
V-2SF	19.2	45	120	20	32,500
V-2SF	19.3	45	120	20	32,500
V-2SF	19.4	45	120	20	32,500
V-2SF	19.5	45	120	20	25,000
V-2SF	19.6	45	120	20	32,500
V-2SF	19.7	45	120	20	32,500
V-2SF	19.8	45	120	20	32,500
V-2SF	19.9	45	120	20	32,500
V-2SF	20	45	120	20	23,400

※ 特定代理店のみの扱いです。

(V-2SF)  
**Vコート3Sエンドミル 2枚刃**  
*2-Flute V-coat Standard End Mills*

材質=粉末ハイス  
 刃数=2枚  
 リード角=右振り30°  
 刃径公差=0~-0.03(D≤20)  
 0~-0.04(D>20)

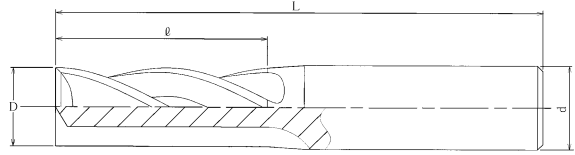
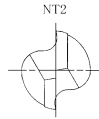

●注文例=型番、刃径、数量 「V-2SF 26」

型番	刃径 (D)	刃長 (ℓ)	全長 (L)	シャンク径 (d)	標準価格
V-2SF	22	45	120	20	28,000
V-2SF	24	50	140	25	36,200
V-2SF	25	50	140	25	36,200
V-2SF	26	50	140	25	43,300
V-2SF	28	55	145	25	51,500
V-2SF	30	55	145	25	62,100
V-2SF	32	60	160	32	75,600
V-2SF	35	60	160	32	90,300
V-2SF	40	65	165	32	126,700

※ 特定代理店のみの扱いです。

(4SF)  
3Sエンドミル 4枚刃(標準刃)  
4-Flute Standard End Mills

SINCE 1935  
F.K.D.®

材質=HSS-Co  
刃数=4枚  
リード角=右捩れ30°  
刃径公差=0~+0.03  
(センター穴付)

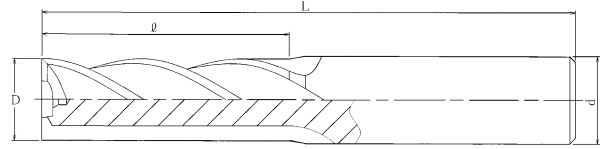

●注用例=型番、刃径、数量 「4SF 3」 ※φ40径以上のサイズはシャンク径もご指定下さい。

型番	刃径 (D)	刃長 (ℓ)	全長 (L)	シャンク径 (d)	標準価格
4SF	3	13	51	6	3,800
4SF	3.1	13	51	6	4,900
4SF	3.2	13	51	6	4,900
4SF	3.3	13	51	6	4,900
4SF	3.4	13	51	6	4,900
4SF	3.5	16	54	6	3,800
4SF	3.6	16	54	6	4,900
4SF	3.7	16	54	6	4,900
4SF	3.8	16	54	6	4,900
4SF	3.9	16	54	6	4,900
4SF	4	16	54	6	3,800
4SF	4.1	16	54	6	4,900
4SF	4.2	16	54	6	4,900
4SF	4.3	16	54	6	4,900
4SF	4.4	16	54	6	4,900
4SF	4.5	18	56	6	3,800
4SF	4.6	18	56	6	4,900
4SF	4.7	18	56	6	4,900
4SF	4.8	18	56	6	4,900
4SF	4.9	18	56	6	4,900
4SF	5	18	56	6	3,800
4SF	5.1	18	56	6	4,900
4SF	5.2	18	56	6	4,900
4SF	5.3	18	56	6	4,900
4SF	5.4	18	56	6	4,900
4SF	5.5	20	58	6	3,800
4SF	5.6	20	58	6	4,900
4SF	5.7	20	58	6	4,900
4SF	5.8	20	58	6	4,900
4SF	5.9	20	58	6	4,900
4SF	6	20	58	6	3,800
4SF	6.1	20	58	6	5,400
4SF	6.2	20	58	8	5,400
4SF	6.3	20	58	8	5,400
4SF	6.4	20	58	8	5,400
4SF	6.5	22	60	8	4,300
4SF	6.6	22	60	8	5,400
4SF	6.7	22	60	8	5,400
4SF	6.8	22	60	8	5,400
4SF	6.9	22	60	8	5,400
4SF	7	22	60	8	4,300
4SF	7.1	22	60	8	5,400
4SF	7.2	22	60	8	5,400
4SF	7.3	22	60	8	5,400
4SF	7.4	22	60	8	5,400
4SF	7.5	25	62	8	4,300
4SF	7.6	25	62	8	5,400
4SF	7.7	25	62	8	5,400
4SF	7.8	25	62	8	5,400

型番	刃径 (D)	刃長 (ℓ)	全長 (L)	シャンク径 (d)	標準価格
4SF	7.9	25	62	8	5,400
4SF	8	25	62	8	4,300
4SF	8.1	25	62	8	6,500
4SF	8.2	25	62	10	6,500
4SF	8.3	25	62	10	6,500
4SF	8.4	25	62	10	6,500
4SF	8.5	26	64	10	4,900
4SF	8.6	26	64	10	6,500
4SF	8.7	26	64	10	6,500
4SF	8.8	26	64	10	6,500
4SF	8.9	26	64	10	6,500
4SF	9	26	64	10	4,900
4SF	9.1	26	64	10	6,500
4SF	9.2	26	64	10	6,500
4SF	9.3	26	64	10	6,500
4SF	9.4	26	64	10	6,500
4SF	9.5	30	67	10	4,900
4SF	9.6	30	67	10	6,500
4SF	9.7	30	67	10	6,500
4SF	9.8	30	67	10	6,500
4SF	9.9	30	67	10	6,500
4SF	10	30	67	10	4,900
4SF	10.1	30	67	10	7,600
4SF	10.2	30	67	12	7,600
4SF	10.3	30	67	12	7,600
4SF	10.4	30	67	12	7,600
4SF	10.5	32	77	12	6,100
4SF	10.6	32	77	12	7,600
4SF	10.7	32	77	12	7,600
4SF	10.8	32	77	12	7,600
4SF	10.9	32	77	12	7,600
4SF	11	32	77	12	6,100
4SF	11.1	32	77	12	7,600
4SF	11.2	32	77	12	7,600
4SF	11.3	32	77	12	7,600
4SF	11.4	32	77	12	7,600
4SF	11.5	35	84	12	7,600
4SF	11.6	35	84	12	7,600
4SF	11.7	35	84	12	7,600
4SF	11.8	35	84	12	7,600
4SF	11.9	35	84	12	7,600
4SF	12	35	84	12	6,100
4SF	12.1	35	84	12	9,000
4SF	12.2	35	84	12	9,000
4SF	12.3	35	84	12	9,000
4SF	12.4	35	84	12	9,000
4SF	12.5	39	89	12	9,000
4SF	12.6	39	89	12	9,000
4SF	12.7	39	89	12	9,000



(4SF)  
3Sエンドミル 4枚刃(標準刃)  
4-Flute Standard End Mills

SINCE 1935  
F.K.D.®

材質=HSS-Co  
刃数=4枚  
リード角=右捩れ30°  
刃径公差=0~+0.03  
(センター穴付)

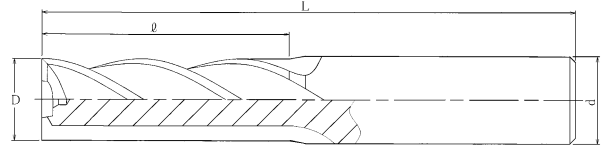
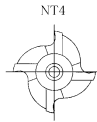

●注用例=型番、刃径、数量 「4SF 12.8」 ※φ40径以上のサイズはシャンク径もご指定下さい。

型番	刃径 (D)	刃長 (ℓ)	全長 (L)	シャンク径 (d)	標準価格
4SF	12.8	39	89	12	9,000
4SF	12.9	39	89	12	9,000
4SF	13	39	89	12	7,400
4SF	13.1	39	89	12	9,000
4SF	13.2	39	89	12	9,000
4SF	13.3	39	89	12	9,000
4SF	13.4	39	89	12	9,000
4SF	13.5	39	89	12	9,000
4SF	13.6	39	89	12	9,000
4SF	13.7	39	89	12	9,000
4SF	13.8	39	89	12	9,000
4SF	13.9	39	89	12	9,000
4SF	14	39	89	12	7,400
4SF	14.1	39	89	12	10,200
4SF	14.2	39	89	12	10,200
4SF	14.3	39	89	12	10,200
4SF	14.4	39	89	12	10,200
4SF	14.5	45	97	16	10,200
4SF	14.6	45	97	16	10,200
4SF	14.7	45	97	16	10,200
4SF	14.8	45	97	16	10,200
4SF	14.9	45	97	16	10,200
4SF	15	45	97	16	7,800
4SF	15.1	45	97	16	10,900
4SF	15.2	45	97	16	10,900
4SF	15.3	45	97	16	10,900
4SF	15.4	45	97	16	10,900
4SF	15.5	45	97	16	10,900
4SF	15.6	45	97	16	10,900
4SF	15.7	45	97	16	10,900
4SF	15.8	45	97	16	10,900
4SF	15.9	45	97	16	10,900
4SF	16	45	97	16	8,700
4SF	16.1	45	97	16	13,600
4SF	16.2	45	97	16	13,600
4SF	16.3	45	97	16	13,600
4SF	16.4	45	97	16	13,600
4SF	16.5	45	100	16	13,600
4SF	16.6	45	100	16	13,600
4SF	16.7	45	100	16	13,600
4SF	16.8	45	100	16	13,600
4SF	16.9	45	100	16	13,600
4SF	17	45	100	16	10,900
4SF	17.1	45	100	16	13,600
4SF	17.2	45	100	16	13,600
4SF	17.3	45	100	16	13,600
4SF	17.4	45	100	16	13,600
4SF	17.5	45	100	16	13,600
4SF	17.6	45	100	16	13,600

型番	刃径 (D)	刃長 (ℓ)	全長 (L)	シャンク径 (d)	標準価格
4SF	17.7	45	100	16	13,600
4SF	17.8	45	100	16	13,600
4SF	17.9	45	100	16	13,600
4SF	18	45	100	16	10,900
4SF	18.1	45	100	16	16,200
4SF	18.2	45	100	16	16,200
4SF	18.3	45	100	16	16,200
4SF	18.4	45	100	16	16,200
4SF	18.5	50	115	20	16,200
4SF	18.6	50	115	20	16,200
4SF	18.7	50	115	20	16,200
4SF	18.8	50	115	20	16,200
4SF	18.9	50	115	20	16,200
4SF	19	50	115	20	12,800
4SF	19.1	50	115	20	16,200
4SF	19.2	50	115	20	16,200
4SF	19.3	50	115	20	16,200
4SF	19.4	50	115	20	16,200
4SF	19.5	50	115	20	16,200
4SF	19.6	50	115	20	16,200
4SF	19.7	50	115	20	16,200
4SF	19.8	50	115	20	16,200
4SF	19.9	50	115	20	16,200
4SF	20	50	115	20	12,800
4SF	20.1	50	115	20	19,500
4SF	20.2	50	115	20	19,500
4SF	20.3	50	115	20	19,500
4SF	20.4	50	115	20	19,500
4SF	20.5	50	115	20	19,500
4SF	20.6	50	115	20	19,500
4SF	20.7	50	115	20	19,500
4SF	20.8	50	115	20	19,500
4SF	20.9	50	115	20	19,500
4SF	21	50	115	20	15,700
4SF	21.1	50	115	20	19,500
4SF	21.2	50	115	20	19,500
4SF	21.3	50	115	20	19,500
4SF	21.4	50	115	20	19,500
4SF	21.5	50	115	20	19,500
4SF	21.6	50	115	20	19,500
4SF	21.7	50	115	20	19,500
4SF	21.8	50	115	20	19,500
4SF	21.9	50	115	20	19,500
4SF	22	50	115	20	15,700
4SF	22.1	50	115	20	23,700
4SF	22.2	50	115	20	23,700
4SF	22.3	50	115	20	23,700
4SF	22.4	50	115	20	23,700
4SF	22.5	55	125	25	23,700

(4SF)  
3Sエンドミル 4枚刃(標準刃)  
4-Flute Standard End Mills



材質=HSS-Co  
刃数=4枚  
リード角=右捩れ30°  
刃径公差=0~+0.03  
(センター穴付)

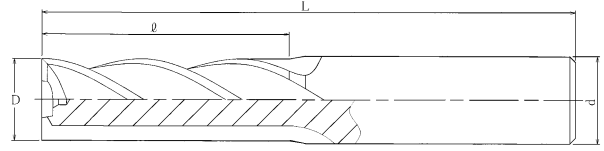

●注用例=型番、刃径、数量 「4SF 22.6」 ※φ40径以上のサイズはシャンク径もご指定下さい。

型番	刃径 (D)	刃長 (ℓ)	全長 (L)	シャンク径 (d)	標準価格
4SF	22.6	55	125	25	23,700
4SF	22.7	55	125	25	23,700
4SF	22.8	55	125	25	23,700
4SF	22.9	55	125	25	23,700
4SF	23	55	125	25	19,000
4SF	23.1	55	125	25	23,700
4SF	23.2	55	125	25	23,700
4SF	23.3	55	125	25	23,700
4SF	23.4	55	125	25	23,700
4SF	23.5	55	125	25	23,700
4SF	23.6	55	125	25	23,700
4SF	23.7	55	125	25	23,700
4SF	23.8	55	125	25	23,700
4SF	23.9	55	125	25	23,700
4SF	24	55	125	25	19,000
4SF	24.1	55	125	25	23,700
4SF	24.2	55	125	25	23,700
4SF	24.3	55	125	25	23,700
4SF	24.4	55	125	25	23,700
4SF	24.5	55	125	25	23,700
4SF	24.6	55	125	25	23,700
4SF	24.7	55	125	25	23,700
4SF	24.8	55	125	25	23,700
4SF	24.9	55	125	25	23,700
4SF	25	55	125	25	19,000
4SF	25.1	55	125	25	25,200
4SF	25.2	55	125	25	25,200
4SF	25.3	55	125	25	25,200
4SF	25.4	55	125	25	25,200
4SF	25.5	55	125	25	25,200
4SF	25.6	55	125	25	25,200
4SF	25.7	55	125	25	25,200
4SF	25.8	55	125	25	25,200
4SF	25.9	55	125	25	25,200
4SF	26	55	125	25	20,200
4SF	26.1	55	125	25	25,200
4SF	26.2	55	125	25	25,200
4SF	26.3	55	125	25	25,200
4SF	26.4	55	125	25	25,200
4SF	26.5	60	130	25	30,100
4SF	26.6	60	130	25	30,100
4SF	26.7	60	130	25	30,100
4SF	26.8	60	130	25	30,100
4SF	26.9	60	130	25	30,100
4SF	27	60	130	25	24,100
4SF	27.1	60	130	25	30,100
4SF	27.2	60	130	25	30,100
4SF	27.3	60	130	25	30,100
4SF	27.4	60	130	25	30,100

型番	刃径 (D)	刃長 (ℓ)	全長 (L)	シャンク径 (d)	標準価格
4SF	27.5	60	130	25	30,100
4SF	27.6	60	130	25	30,100
4SF	27.7	60	130	25	30,100
4SF	27.8	60	130	25	30,100
4SF	27.9	60	130	25	30,100
4SF	28	60	130	25	24,100
4SF	28.1	60	130	25	36,400
4SF	28.2	60	130	25	36,400
4SF	28.3	60	130	25	36,400
4SF	28.4	60	130	25	36,400
4SF	28.5	60	130	25	36,400
4SF	28.6	60	130	25	36,400
4SF	28.7	60	130	25	36,400
4SF	28.8	60	130	25	36,400
4SF	28.9	60	130	25	36,400
4SF	29	60	130	25	29,200
4SF	29.1	60	130	25	36,400
4SF	29.2	60	130	25	36,400
4SF	29.3	60	130	25	36,400
4SF	29.4	60	130	25	36,400
4SF	29.5	60	130	25	36,400
4SF	29.6	60	130	25	36,400
4SF	29.7	60	130	25	36,400
4SF	29.8	60	130	25	36,400
4SF	29.9	60	130	25	36,400
4SF	30	60	130	25	29,200
4SF	30.5	65	135	32	43,200
4SF	31	65	135	32	34,500
4SF	31.5	65	135	32	43,200
4SF	32	65	135	32	34,500
4SF	32.5	65	145	32	50,100
4SF	33	65	145	32	41,100
4SF	33.5	65	145	32	50,100
4SF	34	65	145	32	41,100
4SF	34.5	65	145	32	50,600
4SF	35	65	145	32	41,800
4SF	35.5	65	145	32	56,000
4SF	36	65	145	32	46,900
4SF	36.5	70	150	32	60,200
4SF	37	70	150	32	50,400
4SF	37.5	70	150	32	60,200
4SF	38	70	150	32	50,400
4SF	38.5	70	150	32	69,400
4SF	39	70	150	32	58,100
4SF	39.5	70	150	32	69,400
4SF	40	70	150	32	58,100
4SF	40	70	165	42	60,700
4SF	41	70	155	32	66,700
4SF	41	70	165	42	69,400

(4SF)  
3Sエンドミル 4枚刃(標準刃)  
4-Flute Standard End Mills

SINCE 1935  
F.K.D.®

材質=HSS-Co  
刃数=4枚  
リード角=右捩れ30°  
刃径公差=0~+0.03  
(センター穴付)

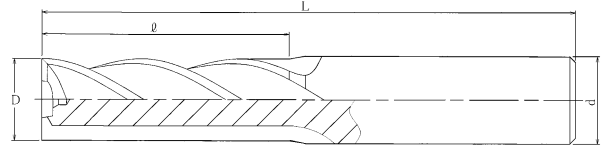

●注文例=型番、刃径、シャンク、数量「4SF 42x32」 ※φ40径以上のサイズはシャンク径もご指定下さい。

型番	刃径 (D)	刃長 (ℓ)	全長 (L)	シャンク径 (d)	標準価格
4SF	42	70	155	32	66,700
4SF	42	70	165	42	69,400
4SF	43	75	160	32	75,400
4SF	43	75	170	42	78,400
4SF	44	75	160	32	75,400
4SF	44	75	170	42	78,400
4SF	45	75	160	32	85,500
4SF	45	75	170	42	88,900
4SF	46	75	160	32	85,500
4SF	46	75	170	42	88,900
4SF	47	75	160	32	88,800
4SF	47	75	170	42	92,500
4SF	48	75	160	32	88,800
4SF	48	75	170	42	92,500
4SF	49	75	160	32	99,000
4SF	49	75	170	42	103,500
4SF	50	75	160	32	99,000
4SF	50	75	170	42	103,500
4SF	50.5	75	160	32	141,100
4SF	50.5	75	170	42	141,100
4SF	51	75	160	32	112,800
4SF	51	75	170	42	117,400
4SF	52	75	160	32	112,800
4SF	52	75	170	42	117,400
4SF	53	75	160	32	124,700
4SF	53	75	170	42	130,000
4SF	54	75	160	32	124,700
4SF	54	75	170	42	130,000
4SF	55	75	160	32	124,700
4SF	55	75	170	42	130,000
4SF	56	75	160	32	136,600
4SF	56	75	170	42	142,500
4SF	57	75	160	32	136,600
4SF	57	75	170	42	142,500
4SF	58	75	160	32	136,600
4SF	58	75	170	42	142,500

型番	刃径 (D)	刃長 (ℓ)	全長 (L)	シャンク径 (d)	標準価格
4SF	59	75	160	32	145,200
4SF	59	75	170	42	151,300
4SF	60	75	160	32	145,200
4SF	60	75	170	42	151,300
4SF	61	80	165	32	174,400
4SF	61	80	175	42	181,500
4SF	62	80	165	32	174,400
4SF	62	80	175	42	181,500
4SF	63	80	165	32	203,300
4SF	63	80	175	42	211,600
4SF	64	80	165	32	203,300
4SF	64	80	175	42	211,600
4SF	65	80	165	32	203,300
4SF	65	80	175	42	211,600
4SF	66	80	165	32	223,700
4SF	66	80	175	42	233,000
4SF	67	80	165	32	223,700
4SF	67	80	175	42	233,000
4SF	68	80	165	32	223,700
4SF	68	80	175	42	233,000
4SF	69	80	165	32	223,700
4SF	69	80	175	42	233,000
4SF	70	80	165	32	223,700
4SF	70	80	175	42	233,000
4SF	75	80	180	32	264,800
4SF	75	80	180	42	275,700
4SF	80	80	180	32	302,200
4SF	80	80	180	42	315,000
4SF	85	80	180	32	331,400
4SF	85	80	180	42	345,100
4SF	90	80	180	32	356,800
4SF	90	80	180	42	371,700
4SF	95	80	180	32	390,900
4SF	95	80	180	42	407,300
4SF	100	80	180	32	415,000
4SF	100	80	180	42	432,400

●注文例=型番、刃径、数量「4SF 1/8"」

型番	刃径 (D)	刃長 (ℓ)	全長 (L)	シャンク径 (d)	標準価格
4SF	1/8"	13	51	6	5,400
4SF	5/32"	16	54	6	5,400
4SF	3/16"	18	56	6	5,400
4SF	7/32"	20	58	6	5,400
4SF	1/4"	20	58	8	5,900
4SF	5/16"	25	62	8	5,900
4SF	3/8"	30	67	10	6,500
4SF	7/16"	32	77	12	7,900
4SF	1/2"	39	89	12	9,000

型番	刃径 (D)	刃長 (ℓ)	全長 (L)	シャンク径 (d)	標準価格
4SF	9/16"	39	89	12	11,000
4SF	5/8"	45	97	16	16,300
4SF	11/16"	45	100	16	17,700
4SF	3/4"	50	115	20	17,700
4SF	13/16"	50	115	20	18,000
4SF	7/8"	50	115	20	25,200
4SF	15/16"	55	125	25	26,100
4SF	1"	55	125	25	25,200
4SF	1.1/4"	65	135	32	47,300

(6SF)  
3Sエンドミル 6枚刃(標準刃)  
6-Flute Standard End Mills

SINCE 1935  
F.K.D.®

材質=HSS-Co  
刃数=6枚  
リード角=右振り30°  
刃径公差=0~+0.03  
(センター穴付)

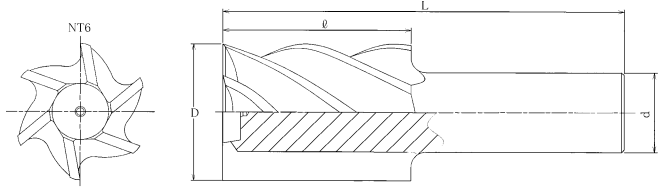

●注文例=型番、刃径、シャンク径、数量「6SF 50x32」

型番	刃径 (D)	刃長 (ℓ)	全長 (L)	シャンク径 (d)	標準価格
6SF	50	75	160	32	99,000
6SF	50	75	170	42	103,500
6SF	51	75	160	32	112,800
6SF	51	75	170	42	117,400
6SF	52	75	160	32	112,800
6SF	52	75	170	42	117,400
6SF	53	75	160	32	124,700
6SF	53	75	170	42	130,000
6SF	54	75	160	32	124,700
6SF	54	75	170	42	130,000
6SF	55	75	160	32	124,700
6SF	55	75	170	42	130,000
6SF	56	75	160	32	136,600
6SF	56	75	170	42	142,500
6SF	57	75	160	32	136,600
6SF	57	75	170	42	142,500
6SF	58	75	160	32	136,600
6SF	58	75	170	42	142,500
6SF	59	75	160	32	145,200
6SF	59	75	170	42	151,300
6SF	60	75	160	32	145,200
6SF	60	75	170	42	151,300
6SF	61	80	165	32	174,400
6SF	61	80	175	42	181,500
6SF	62	80	165	32	174,400
6SF	62	80	175	42	181,500
6SF	63	80	165	32	203,300
6SF	63	80	175	42	211,600

型番	刃径 (D)	刃長 (ℓ)	全長 (L)	シャンク径 (d)	標準価格
6SF	64	80	165	32	203,300
6SF	64	80	175	42	211,600
6SF	65	80	165	32	203,300
6SF	65	80	175	42	211,600
6SF	66	80	165	32	223,700
6SF	66	80	175	42	233,000
6SF	67	80	165	32	223,700
6SF	67	80	175	42	233,000
6SF	68	80	165	32	223,700
6SF	68	80	175	42	233,000
6SF	69	80	165	32	223,700
6SF	69	80	175	42	233,000
6SF	70	80	165	32	223,700
6SF	70	80	175	42	233,000
6SF	75	80	180	32	264,800
6SF	75	80	180	42	275,700
6SF	80	80	180	32	302,200
6SF	80	80	180	42	315,000
6SF	85	80	180	32	331,400
6SF	85	80	180	42	345,100
6SF	90	80	180	32	356,800
6SF	90	80	180	42	371,700
6SF	95	80	180	32	390,900
6SF	95	80	180	42	407,300
6SF	100	80	180	32	415,000
6SF	100	80	180	42	432,400

# (4LF / 4XLF) 3Sエンドミル 4枚刃(ロング・特ロング刃)

4-Flute Long & Extra Long End Mills

SINCE 1935  
F.K.D.®

材質=HSS-Co  
刃数=4枚  
リード角=右振り30°  
刃径公差=0~+0.03  
(センター穴付)

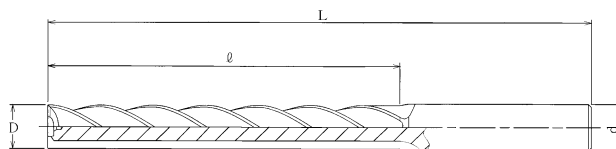

●注用例=型番、刃径、刃長、数量「4LF 3x20」 ※φ40径以上のサイズはシャンク径もご指定下さい。

型番	刃径 (D)	刃長 (l)	全長 (L)	シャンク径 (d)	標準価格
4LF	3	20	58	6	4,900
4XLF	3	30	70	6	5,400
4XLF	3	40	80	6	6,100
4LF	3.1	20	58	6	6,400
4LF	3.2	20	58	6	6,400
4LF	3.3	20	58	6	6,400
4LF	3.4	20	58	6	6,400
4LF	3.5	25	63	6	6,400
4XLF	3.5	30	70	6	6,600
4XLF	3.5	40	80	6	7,400
4LF	3.6	25	63	6	6,400
4LF	3.7	25	63	6	6,400
4LF	3.8	25	63	6	6,400
4LF	3.9	25	63	6	6,400
4LF	4	25	63	6	4,900
4XLF	4	30	70	6	5,400
4XLF	4	40	80	6	6,100
4XLF	4	50	90	6	7,100
4LF	4.1	25	63	6	6,400
4LF	4.2	25	63	6	6,400
4LF	4.3	25	63	6	6,400
4LF	4.4	25	63	6	6,400
4LF	4.5	30	68	6	6,400
4XLF	4.5	40	80	6	7,400
4XLF	4.5	50	90	6	8,500
4LF	4.6	30	68	6	6,400
4LF	4.7	30	68	6	6,400
4LF	4.8	30	68	6	6,400
4LF	4.9	30	68	6	6,400
4LF	5	30	68	6	4,900
4XLF	5	40	80	6	6,100
4XLF	5	50	90	6	7,100
4XLF	5	60	100	6	7,400
4LF	5.1	30	68	6	6,400
4LF	5.2	30	68	6	6,400
4LF	5.3	30	68	6	6,400
4LF	5.4	30	68	6	6,400
4XLF	5.5	30	70	6	6,400
4LF	5.5	35	73	6	6,400
4XLF	5.5	40	80	6	7,400
4XLF	5.5	50	90	6	8,500
4XLF	5.5	60	100	6	9,200
4LF	5.6	35	73	6	6,400
4LF	5.7	35	73	6	6,400
4LF	5.8	35	73	6	6,400
4LF	5.9	35	73	6	6,400

型番	刃径 (D)	刃長 (l)	全長 (L)	シャンク径 (d)	標準価格
4XLF	6	30	70	6	4,900
4LF	6	35	73	6	4,900
4XLF	6	40	80	6	6,100
4XLF	6	50	90	6	7,100
4XLF	6	60	100	6	7,400
4LF	6.1	35	73	6	7,200
4LF	6.2	35	73	8	7,200
4LF	6.3	35	73	8	7,200
4LF	6.4	35	73	8	7,200
4XLF	6.5	30	70	8	7,200
4LF	6.5	35	73	8	7,200
4XLF	6.5	40	80	8	7,400
4XLF	6.5	50	90	8	8,500
4XLF	6.5	60	100	8	9,200
4LF	6.6	35	73	8	7,200
4LF	6.7	35	73	8	7,200
4LF	6.8	35	73	8	7,200
4LF	6.9	35	73	8	7,200
4XLF	7	30	70	8	5,600
4LF	7	35	73	8	5,600
4XLF	7	40	80	8	6,100
4XLF	7	50	90	8	7,100
4XLF	7	60	100	8	7,400
4LF	7.1	35	73	8	7,400
4LF	7.2	35	73	8	7,400
4LF	7.3	35	73	8	7,400
4LF	7.4	35	73	8	7,400
4XLF	7.5	30	70	8	7,200
4LF	7.5	40	78	8	7,400
4XLF	7.5	50	90	8	8,500
4XLF	7.5	60	100	8	9,200
4XLF	7.5	80	120	8	11,200
4LF	7.6	40	78	8	7,400
4LF	7.7	40	78	8	7,400
4LF	7.8	40	78	8	7,400
4LF	7.9	40	78	8	7,400
4XLF	8	30	70	8	5,600
4LF	8	40	78	8	6,100
4XLF	8	50	90	8	7,100
4XLF	8	60	100	8	7,400
4XLF	8	80	120	8	8,600
4XLF	8	100	140	8	12,700
4LF	8.1	40	78	8	7,400
4LF	8.2	40	78	10	7,400
4LF	8.3	40	78	10	7,400
4LF	8.4	40	78	10	7,400

# (4LF / 4XLF) 3Sエンドミル 4枚刃(ロング・特ロング刃)

SINCE 1935  
F.K.D.®

4-Flute Long & Extra Long End Mills

材質=HSS-Co  
刃数=4枚  
リード角=右振り30°  
刃径公差=0~+0.03  
(センター穴付)

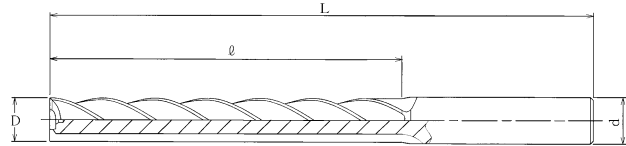

●注文例=型番、刃径、刃長、数量 「4XLF 8.5x30」 ※φ40径以上のサイズはシャンク径もご指定下さい。

型番	刃径 (D)	刃長 (l)	全長 (L)	シャンク径 (d)	標準価格
4XLF	8.5	30	70	10	7,400
4XLF	8.5	40	80	10	7,400
4LF	8.5	45	83	10	7,400
4XLF	8.5	50	90	10	8,500
4XLF	8.5	60	100	10	9,200
4XLF	8.5	80	120	10	11,200
4XLF	8.5	100	140	10	16,200
4LF	8.6	45	83	10	7,400
4LF	8.7	45	83	10	7,400
4LF	8.8	45	83	10	7,400
4LF	8.9	45	83	10	7,400
4XLF	9	40	80	10	6,100
4LF	9	45	83	10	6,100
4XLF	9	50	90	10	7,100
4XLF	9	60	100	10	7,400
4XLF	9	80	120	10	8,600
4XLF	9	100	140	10	12,700
4LF	9.1	45	83	10	7,400
4LF	9.2	45	83	10	7,400
4LF	9.3	45	83	10	7,400
4LF	9.4	45	83	10	7,400
4LF	9.5	45	83	10	7,400
4XLF	9.5	50	90	10	8,500
4XLF	9.5	60	100	10	9,200
4XLF	9.5	80	120	10	11,200
4XLF	9.5	100	140	10	16,200
4LF	9.6	45	83	10	7,400
4LF	9.7	45	83	10	7,400
4LF	9.8	45	83	10	7,400
4LF	9.9	45	83	10	7,400
4XLF	10	40	80	10	6,100
4LF	10	45	83	10	6,100
4XLF	10	50	90	10	7,100
4XLF	10	60	100	10	7,400
4XLF	10	80	120	10	8,600
4XLF	10	100	140	10	12,700
4LF	10.1	45	83	10	9,000
4LF	10.2	45	83	12	9,000
4LF	10.3	45	83	12	9,000
4LF	10.4	45	83	12	9,000
4LF	10.5	50	95	12	9,000
4XLF	10.5	60	105	12	11,600
4XLF	10.5	80	125	12	11,600
4XLF	10.5	100	145	12	15,700
4LF	10.6	50	95	12	9,000
4LF	10.7	50	95	12	9,000

型番	刃径 (D)	刃長 (l)	全長 (L)	シャンク径 (d)	標準価格
4LF	10.8	50	95	12	9,000
4LF	10.9	50	95	12	9,000
4XLF	11	40	85	12	7,400
4LF	11	50	95	12	7,400
4XLF	11	60	105	12	9,400
4XLF	11	80	125	12	9,400
4XLF	11	100	145	12	12,500
4LF	11.1	50	95	12	9,000
4LF	11.2	50	95	12	9,000
4LF	11.3	50	95	12	9,000
4LF	11.4	50	95	12	9,000
4LF	11.5	50	95	12	9,000
4XLF	11.5	60	105	12	11,600
4XLF	11.5	80	125	12	11,600
4XLF	11.5	100	145	12	15,700
4LF	11.6	50	95	12	9,000
4LF	11.7	50	95	12	9,000
4LF	11.8	50	95	12	9,000
4LF	11.9	50	95	12	9,000
4XLF	12	40	85	12	7,400
4LF	12	50	95	12	7,400
4XLF	12	60	105	12	9,400
4XLF	12	80	125	12	9,400
4XLF	12	100	145	12	12,500
4XLF	12	120	185	12	26,400
4LF	12.1	50	95	12	11,600
4LF	12.2	50	95	12	11,600
4LF	12.3	50	95	12	11,600
4LF	12.4	50	95	12	11,600
4LF	12.5	55	105	12	11,600
4XLF	12.5	60	110	12	11,900
4XLF	12.5	80	130	12	14,000
4XLF	12.5	100	150	12	16,500
4XLF	12.5	120	185	12	33,100
4LF	12.6	55	105	12	11,600
4LF	12.7	55	105	12	11,600
4LF	12.8	55	105	12	11,600
4LF	12.9	55	105	12	11,600
4LF	13	55	105	12	9,400
4XLF	13	60	110	12	9,600
4XLF	13	80	130	12	11,400
4XLF	13	100	150	12	13,200
4XLF	13	120	185	12	26,400
4LF	13.1	55	105	12	11,600
4LF	13.2	55	105	12	11,600
4LF	13.3	55	105	12	11,600

# (4LF / 4XLF) 3Sエンドミル 4枚刃(ロング・特ロング刃)

SINCE 1935  
F.K.D.®

4-Flute Long & Extra Long End Mills

材質=HSS-Co  
刃数=4枚  
リード角=右振り30°  
刃径公差=0~+0.03  
(センター穴付)

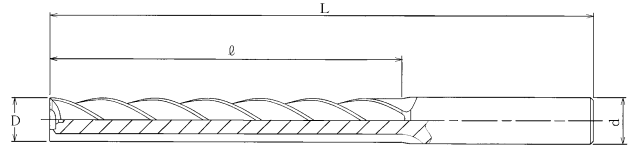

●注文例=型番、刃径、刃長、数量 「4LF 13.4x55」 ※φ40径以上のサイズはシャンク径もご指定下さい。

型番	刃径 (D)	刃長 (l)	全長 (L)	シャンク径 (d)	標準価格
4LF	13.4	55	105	12	11,600
4LF	13.5	55	105	12	11,600
4XLF	13.5	60	110	12	11,900
4XLF	13.5	80	130	12	14,000
4XLF	13.5	100	150	12	16,500
4XLF	13.5	120	185	12	33,100
4LF	13.6	55	105	12	11,600
4LF	13.7	55	105	12	11,600
4LF	13.8	55	105	12	11,600
4LF	13.9	55	105	12	11,600
4XLF	14	50	100	12	8,900
4LF	14	55	105	12	9,400
4XLF	14	60	110	12	9,600
4XLF	14	80	130	12	11,400
4XLF	14	100	150	12	13,200
4XLF	14	120	185	12	26,400
4LF	14.1	55	105	12	13,200
4LF	14.2	55	105	12	13,200
4LF	14.3	55	105	12	13,200
4LF	14.4	55	105	12	13,200
4LF	14.5	60	110	16	13,200
4XLF	14.5	80	130	16	14,600
4XLF	14.5	100	150	16	19,300
4XLF	14.5	120	185	16	34,000
4LF	14.6	60	110	16	13,200
4LF	14.7	60	110	16	13,200
4LF	14.8	60	110	16	13,200
4LF	14.9	60	110	16	13,200
4LF	15	60	110	16	10,500
4XLF	15	80	130	16	11,800
4XLF	15	100	150	16	15,400
4XLF	15	120	185	16	27,100
4LF	15.1	60	110	16	14,300
4LF	15.2	60	110	16	14,300
4LF	15.3	60	110	16	14,300
4LF	15.4	60	110	16	14,300
4LF	15.5	60	110	16	14,300
4XLF	15.5	80	130	16	16,300
4XLF	15.5	100	150	16	21,100
4XLF	15.5	120	185	16	34,000
4LF	15.6	60	110	16	14,300
4LF	15.7	60	110	16	14,300
4LF	15.8	60	110	16	14,300
4LF	15.9	60	110	16	14,300
4LF	16	60	110	16	11,600
4XLF	16	80	130	16	12,900

型番	刃径 (D)	刃長 (l)	全長 (L)	シャンク径 (d)	標準価格
4XLF	16	100	150	16	16,600
4XLF	16	120	185	16	27,100
4XLF	16	150	215	16	33,700
4LF	16.1	60	110	16	17,400
4LF	16.2	60	110	16	17,400
4LF	16.3	60	110	16	17,400
4LF	16.4	60	110	16	17,400
4LF	16.5	65	120	16	17,400
4XLF	16.5	80	135	16	19,700
4XLF	16.5	100	155	16	24,400
4LF	16.6	65	120	16	17,400
4LF	16.7	65	120	16	17,400
4LF	16.8	65	120	16	17,400
4LF	16.9	65	120	16	17,400
4XLF	17	60	115	16	14,000
4LF	17	65	120	16	14,000
4XLF	17	80	135	16	16,100
4XLF	17	100	155	16	19,500
4XLF	17	120	185	16	27,100
4XLF	17	150	215	16	33,700
4LF	17.1	65	120	16	17,400
4LF	17.2	65	120	16	17,400
4LF	17.3	65	120	16	17,400
4LF	17.4	65	120	16	17,400
4LF	17.5	65	120	16	17,400
4XLF	17.5	80	135	16	19,700
4XLF	17.5	100	155	16	24,400
4LF	17.6	65	120	16	17,400
4LF	17.7	65	120	16	17,400
4LF	17.8	65	120	16	17,400
4LF	17.9	65	120	16	17,400
4XLF	18	60	115	16	14,000
4LF	18	65	120	16	14,000
4XLF	18	80	135	16	16,100
4XLF	18	100	155	16	19,500
4XLF	18	120	185	16	27,100
4XLF	18	150	215	16	33,700
4LF	18.1	65	120	16	20,100
4LF	18.2	65	120	16	20,100
4LF	18.3	65	120	16	20,100
4LF	18.4	65	120	16	20,100
4LF	18.5	70	135	20	20,100
4XLF	18.5	80	145	20	21,100
4XLF	18.5	100	165	20	28,700
4LF	18.6	70	135	20	20,100
4LF	18.7	70	135	20	20,100

# (4LF / 4XLF) 3Sエンドミル 4枚刃(ロング・特ロング刃)

4-Flute Long & Extra Long End Mills

SINCE 1935  
F.K.D.®

材質=HSS-Co  
刃数=4枚  
リード角=右振り30°  
刃径公差=0~+0.03  
(センター穴付)

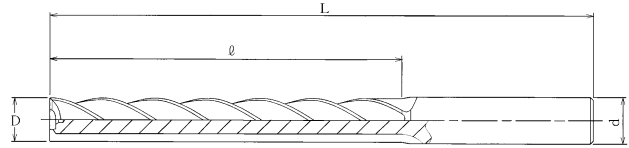

●注用例=型番、刃径、刃長、数量 「4LF 18.8x70」 ※φ40径以上のサイズはシャンク径もご指定下さい。

型番	刃径 (D)	刃長 (l)	全長 (L)	シャンク径 (d)	標準価格
4LF	18.8	70	135	20	20,100
4LF	18.9	70	135	20	20,100
4LF	19	70	135	20	16,200
4XLF	19	80	145	20	16,600
4XLF	19	100	165	20	22,900
4XLF	19	150	215	20	33,700
4LF	19.1	70	135	20	20,100
4LF	19.2	70	135	20	20,100
4LF	19.3	70	135	20	20,100
4LF	19.4	70	135	20	20,100
4LF	19.5	70	135	20	20,100
4XLF	19.5	80	145	20	21,100
4XLF	19.5	100	165	20	28,700
4LF	19.6	70	135	20	20,100
4LF	19.7	70	135	20	20,100
4LF	19.8	70	135	20	20,100
4LF	19.9	70	135	20	20,100
4XLF	20	60	115	20	16,200
4LF	20	70	135	20	16,200
4XLF	20	80	145	20	16,600
4XLF	20	100	165	20	22,900
4XLF	20	120	185	20	27,800
4XLF	20	150	215	20	33,700
4XLF	20	180	245	20	44,800
4XLF	20	200	270	20	52,400
4LF	20.1	70	135	20	24,800
4LF	20.2	70	135	20	24,800
4LF	20.3	70	135	20	24,800
4LF	20.4	70	135	20	24,800
4LF	20.5	75	140	20	24,800
4XLF	20.5	80	145	20	25,500
4XLF	20.5	100	165	20	32,700
4LF	20.6	75	140	20	24,800
4LF	20.7	75	140	20	24,800
4LF	20.8	75	140	20	24,800
4LF	20.9	75	140	20	24,800
4LF	21	75	140	20	19,500
4XLF	21	80	145	20	20,600
4XLF	21	100	165	20	26,100
4XLF	21	120	185	20	31,400
4XLF	21	150	215	20	39,700
4LF	21.5	75	140	20	24,800
4XLF	21.5	80	145	20	25,500
4XLF	21.5	100	165	20	32,700
4LF	22	75	140	20	19,500
4XLF	22	80	145	20	20,600

型番	刃径 (D)	刃長 (l)	全長 (L)	シャンク径 (d)	標準価格
4XLF	22	100	165	20	26,100
4XLF	22	120	185	20	31,400
4XLF	22	150	215	20	39,700
4XLF	22	180	245	20	49,700
4XLF	22	200	270	20	62,200
4LF	22.5	80	150	25	30,100
4XLF	22.5	100	170	25	35,600
4LF	23	80	150	25	24,100
4XLF	23	100	170	25	28,400
4XLF	23	120	190	25	35,300
4XLF	23	150	220	25	41,500
4LF	23.5	80	150	25	30,100
4XLF	23.5	100	170	25	35,600
4XLF	23.5	120	190	25	44,300
4XLF	23.5	150	220	25	51,700
4XLF	23.5	200	270	25	77,700
4LF	24	80	150	25	24,100
4XLF	24	100	170	25	28,400
4XLF	24	120	190	25	35,300
4XLF	24	150	220	25	41,500
4XLF	24	180	250	25	54,200
4XLF	24	200	270	25	62,200
4XLF	24.5	80	150	25	31,700
4LF	24.5	85	155	25	31,700
4XLF	24.5	100	170	25	35,600
4XLF	25	80	150	25	25,300
4LF	25	85	155	25	25,300
4XLF	25	100	170	25	28,400
4XLF	25	120	190	25	38,000
4XLF	25	150	220	25	41,500
4XLF	25	180	250	25	56,800
4XLF	25	200	270	25	63,300
4XLF	25.5	80	150	25	31,700
4LF	25.5	85	155	25	35,200
4XLF	25.5	100	170	25	39,500
4XLF	25.5	120	190	25	53,000
4XLF	26	80	150	25	25,300
4LF	26	85	155	25	28,100
4XLF	26	100	170	25	31,400
4XLF	26	120	190	25	42,500
4XLF	26	150	220	25	48,800
4XLF	26	180	250	25	61,500
4XLF	26	200	270	25	64,700
4LF	26.5	90	160	25	40,700
4XLF	26.5	100	170	25	39,500
4XLF	26.5	120	190	25	59,300



# (4LF / 4XLF) 3Sエンドミル 4枚刃(ロング・特ロング刃)

SINCE 1935  
F.K.D.®

4-Flute Long & Extra Long End Mills

材質=HSS-Co  
刃数=4枚  
リード角=右振り30°  
刃径公差=0~+0.03  
(センター穴付)

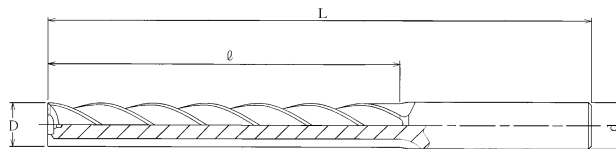

●注文例=型番、刃径、刃長、シャンク径、数量「4LF 27x90」 ※φ40径以上のサイズはシャンク径もご指定下さい。

型番	刃径 (D)	刃長 (l)	全長 (L)	シャンク径 (d)	標準価格
4LF	27	90	160	25	32,700
4XLF	27	100	170	25	31,400
4XLF	27	120	190	25	47,500
4XLF	27	150	220	25	54,200
4LF	27.5	90	160	25	40,700
4XLF	27.5	100	170	25	39,500
4XLF	27.5	120	190	25	59,300
4LF	28	90	160	25	32,700
4XLF	28	100	170	25	31,400
4XLF	28	120	190	25	47,500
4XLF	28	150	220	25	54,200
4XLF	28	180	250	25	73,400
4XLF	28	200	270	25	81,300
4LF	28.5	95	165	25	49,200
4XLF	28.5	100	170	25	53,400
4XLF	28.5	120	190	25	69,600
4LF	29	95	165	25	39,400
4XLF	29	100	170	25	42,900
4XLF	29	120	190	25	55,700
4XLF	29	150	220	25	61,100
4XLF	29	200	270	25	98,800
4LF	29.5	95	165	25	49,200
4XLF	29.5	100	170	25	53,400
4XLF	29.5	120	190	25	69,600
4LF	30	95	165	25	39,400
4XLF	30	100	170	25	42,900
4XLF	30	120	190	25	55,700
4XLF	30	150	220	25	61,100
4XLF	30	180	250	25	86,700
4XLF	30	200	270	25	98,800
4XLF	30	250	350	25	126,600
4LF	30.5	95	165	32	59,100
4LF	31	95	165	32	47,300
4XLF	31	100	170	32	49,700
4XLF	31	120	190	32	61,100
4XLF	31	150	220	32	68,100
4LF	31.5	95	165	32	59,100
4LF	32	95	165	32	47,300
4XLF	32	100	170	32	49,700
4XLF	32	120	190	32	61,100
4XLF	32	150	220	32	68,100
4XLF	32	200	270	32	101,400
4LF	32.5	100	180	32	73,600
4LF	33	100	180	32	59,000
4XLF	33	120	200	32	71,000
4XLF	33	150	230	32	78,800

型番	刃径 (D)	刃長 (l)	全長 (L)	シャンク径 (d)	標準価格
4LF	33.5	100	180	32	74,500
4LF	34	100	180	32	59,500
4XLF	34	120	200	32	71,000
4XLF	34	150	230	32	78,800
4XLF	34	200	280	32	125,300
4LF	34.5	100	180	32	75,700
4LF	35	100	180	32	60,700
4XLF	35	120	200	32	74,800
4XLF	35	150	230	32	82,900
4XLF	35	180	260	32	112,400
4XLF	35	200	280	32	125,300
4XLF	35	250	350	32	150,700
4LF	35.5	100	180	32	81,200
4LF	36	100	180	32	65,000
4XLF	36	120	200	32	77,700
4XLF	36	150	230	32	90,000
4XLF	36	200	280	32	131,200
4LF	36.5	105	185	32	90,500
4LF	37	105	185	32	72,500
4XLF	37	120	200	32	85,300
4XLF	37	150	230	32	96,300
4XLF	37	200	280	32	136,400
4LF	37.5	105	185	32	90,500
4XLF	38	100	180	32	71,900
4LF	38	105	185	32	72,500
4XLF	38	120	200	32	85,300
4XLF	38	150	230	32	96,300
4XLF	38	200	280	32	136,400
4LF	38.5	105	185	32	102,600
4LF	39	105	185	32	82,300
4XLF	39	120	200	32	93,300
4XLF	39	150	230	32	107,700
4LF	39.5	105	185	32	102,600
4XLF	40	100	180	32	82,300
4LF	40	105	185	32	82,300
4LF	40	105	200	42	85,700
4XLF	40	120	200	32	93,300
4XLF	40	120	215	42	97,100
4XLF	40	150	230	32	107,700
4XLF	40	150	245	42	112,200
4XLF	40	180	260	32	137,600
4XLF	40	180	275	42	143,300
4XLF	40	200	280	32	146,400
4XLF	40	200	295	42	152,500
4XLF	40	250	350	32	183,200
4XLF	40	250	350	42	190,700

# (4LF / 4XLF) 3Sエンドミル 4枚刃(ロング・特ロング刃)

SINCE 1935  
F.K.D.®

4-Flute Long & Extra Long End Mills

材質=HSS-Co  
刃数=4枚  
リード角=右振り30°  
刃径公差=0~+0.03  
(センター穴付)

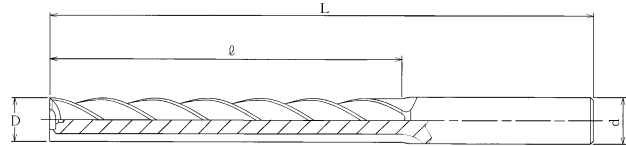

●注用例=型番、刃径、刃長、シャック径、数量「4XLF 40x300x32」

※φ40径以上のサイズはシャック径もご指定下さい。

型番	刃径 (D)	刃長 (l)	全長 (L)	シャック径 (d)	標準価格
4XLF	40	300	400	32	223,400
4LF	41	115	200	32	86,100
4XLF	41	150	235	32	120,200
4XLF	41	150	245	42	125,400
4LF	42	115	200	32	86,100
4LF	42	115	210	42	89,900
4XLF	42	150	235	32	120,200
4XLF	42	150	245	42	125,400
4XLF	42	180	265	32	148,300
4XLF	42	200	285	32	152,500
4XLF	42	200	295	42	158,800
4LF	43	115	200	32	95,000
4XLF	43	150	235	32	125,700
4XLF	43	200	285	32	182,300
4LF	44	115	200	32	95,000
4XLF	44	150	235	32	125,700
4XLF	44	200	285	32	182,300
4LF	45	125	210	32	102,000
4LF	45	125	220	42	106,300
4XLF	45	150	235	32	125,700
4XLF	45	150	245	42	131,200
4XLF	45	180	265	32	168,000
4XLF	45	200	285	32	184,400
4XLF	45	200	295	42	192,100
4XLF	45	250	350	32	233,100
4XLF	45	250	350	42	243,000
4LF	46	125	210	32	102,000
4XLF	46	150	235	32	152,800
4XLF	46	150	245	42	159,200
4XLF	46	200	285	32	189,500
4XLF	46	200	295	42	197,600
4LF	47	125	210	32	112,400

型番	刃径 (D)	刃長 (l)	全長 (L)	シャック径 (d)	標準価格
4XLF	47	150	245	42	159,200
4LF	48	125	210	32	112,400
4XLF	48	150	235	32	152,800
4XLF	48	150	245	42	159,200
4XLF	48	180	265	32	188,900
4XLF	48	200	285	32	195,000
4XLF	48	200	295	42	203,300
4LF	49	125	210	32	137,900
4XLF	49	150	235	32	160,900
4LF	50	125	210	32	137,900
4LF	50	125	220	42	143,900
4XLF	50	150	235	32	160,900
4XLF	50	150	245	42	167,500
4XLF	50	180	265	32	205,900
4XLF	50	200	285	32	219,000
4XLF	50	200	295	42	228,000
4XLF	50	250	350	32	285,200
4XLF	50	250	350	42	297,000
4XLF	50	300	400	42	335,800
4XLF	55	150	235	32	200,900
4XLF	55	150	245	42	209,100
4XLF	55	200	285	32	269,300
4XLF	55	200	295	42	280,500
4XLF	55	250	350	32	328,400
4XLF	55	250	350	42	341,900
4XLF	60	150	235	32	231,900
4XLF	60	150	245	42	241,500
4XLF	60	200	285	32	308,600
4XLF	60	200	295	42	321,300
4XLF	60	250	350	32	386,000
4XLF	60	250	350	42	402,200
4XLF	60	300	400	42	443,900

# (6XLF) 3Sエンドミル 6枚刃(特ロング刃)

SINCE 1935  
**F.K.D.**®

6-Flute Extra Long Flute End Mills

材質=HSS-Co  
刃数=6枚  
リード角=右捩れ30°  
刃径公差=0~+0.03  
(センター穴付)

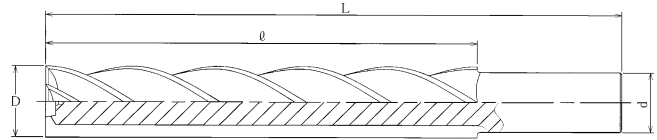

●注文例=型番、刃径、刃長、数量 「6XLF 50x150」

型番	刃径 (D)	刃長 (l)	全長 (L)	シャンク径 (d)	標準価格
6XLF	50	150	245	42	167,500
6XLF	50	200	295	42	228,000
6XLF	50	250	350	42	297,000
6XLF	50	300	400	42	335,800
6XLF	55	150	245	42	209,100
6XLF	55	200	295	42	280,500
6XLF	55	250	350	42	341,900

型番	刃径 (D)	刃長 (l)	全長 (L)	シャンク径 (d)	標準価格
6XLF	60	150	245	42	241,500
6XLF	60	200	295	42	321,300
6XLF	60	250	350	42	402,200

# (LS-4LF) ロングシャンクエンドミル 4枚刃

4-Flute Long Shank End Mills

材質=HSS-Co  
刃数=4枚  
リード角=右捩れ30°  
刃径公差=0~+0.03  
(センターカット)

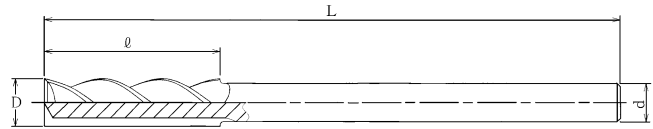

●注文例=型番、刃径、数量 「LS-4LF 3」

型番	刃径 (D)	刃長 (l)	全長 (L)	シャンク径 (d)	標準価格
LS-4LF	3	30	100	6	6,700
LS-4LF	3.5	30	100	6	8,400
LS-4LF	4	30	100	6	6,700
LS-4LF	4.5	30	100	6	8,400
LS-4LF	5	30	100	6	6,700
LS-4LF	5.5	30	100	6	8,400
LS-4LF	6	30	120	6	6,700
LS-4LF	6.5	30	120	6	8,400
LS-4LF	7	30	120	6	6,700
LS-4LF	7.5	35	120	6	10,000
LS-4LF	8	35	120	8	8,000
LS-4LF	8.5	40	120	8	10,000
LS-4LF	9	40	120	8	8,000
LS-4LF	9.5	40	150	8	10,700
LS-4LF	10	40	150	10	8,500
LS-4LF	10.5	45	150	10	12,500
LS-4LF	11	45	150	10	9,900
LS-4LF	11.5	45	150	10	12,500
LS-4LF	12	45	150	12	9,900
LS-4LF	12.5	50	150	12	15,700
LS-4LF	13	50	150	12	12,500
LS-4LF	13.5	50	150	12	15,700
LS-4LF	14	50	150	12	12,500
LS-4LF	14.5	55	180	12	18,700
LS-4LF	15	55	180	12	15,000
LS-4LF	15.5	55	180	12	21,000
LS-4LF	16	55	180	16	16,600

型番	刃径 (D)	刃長 (l)	全長 (L)	シャンク径 (d)	標準価格
LS-4LF	16.5	60	180	16	24,100
LS-4LF	17	60	180	16	19,400
LS-4LF	17.5	60	180	16	24,100
LS-4LF	18	60	180	16	19,400
LS-4LF	18.5	65	200	16	28,100
LS-4LF	19	65	200	16	22,400
LS-4LF	19.5	65	200	16	28,100
LS-4LF	20	65	200	20	22,400
LS-4LF	21	70	200	20	27,500
LS-4LF	22	70	200	20	27,500
LS-4LF	23	75	250	20	33,200
LS-4LF	24	75	250	20	33,200
LS-4LF	25	80	250	25	34,900
LS-4LF	26	80	250	25	38,800
LS-4LF	27	85	250	25	45,400
LS-4LF	28	85	250	25	45,400
LS-4LF	29	100	250	25	54,600
LS-4LF	30	100	250	25	54,600
LS-4LF	32	100	300	32	63,000
LS-4LF	35	100	300	32	76,800
LS-4LF	38	100	300	32	93,900
LS-4LF	40	100	300	32	105,400
LS-4LF	45	120	300	42	147,300
LS-4LF	50	120	300	42	183,900

(XLS-4SF)  
**特ロングシャンクエンドミル 4枚刃**  
 4-Flute Extra Long Shank End Mills



材質=HSS-Co  
 刃数=4枚  
 リード角=右捩れ30°  
 刃径公差=0~+0.03  
 (センター穴付)

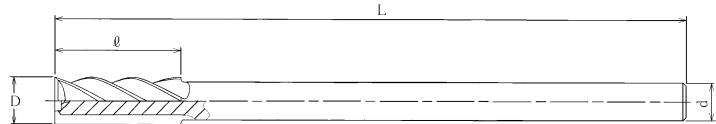

●注文例=型番、刃径、全長、シャンク径、数量「XLS-4SF 8x100」

※φ45径以上はシャンク径もご指定下さい。

型番	刃径 (D)	刃長 (ℓ)	全長 (L)	シャンク径 (d)	標準価格
XLS-4SF	8	20	100	6	8,200
XLS-4SF	8	20	150	6	10,200
XLS-4SF	8.5	25	100	8	10,700
XLS-4SF	8.5	25	150	8	12,600
XLS-4SF	9	25	100	8	8,600
XLS-4SF	9	25	150	8	10,700
XLS-4SF	9.5	25	100	8	10,700
XLS-4SF	9.5	25	150	8	12,600
XLS-4SF	10	25	100	8	8,600
XLS-4SF	10	25	150	8	10,700
XLS-4SF	10.5	30	150	10	12,800
XLS-4SF	10.5	30	200	10	15,000
XLS-4SF	11	30	150	10	10,900
XLS-4SF	11	30	200	10	12,500
XLS-4SF	11.5	30	150	10	12,800
XLS-4SF	11.5	30	200	10	15,000
XLS-4SF	12	30	150	10	10,900
XLS-4SF	12	30	200	10	12,500
XLS-4SF	12.5	35	150	12	16,600
XLS-4SF	12.5	35	200	12	19,300
XLS-4SF	13	35	150	12	13,800
XLS-4SF	13	35	200	12	16,200
XLS-4SF	13.5	35	150	12	16,600
XLS-4SF	13.5	35	200	12	19,300
XLS-4SF	14	35	150	12	13,800
XLS-4SF	14	35	200	12	16,200
XLS-4SF	14.5	40	150	12	19,400
XLS-4SF	14.5	40	200	12	22,700
XLS-4SF	15	40	150	12	16,200
XLS-4SF	15	40	200	12	18,700
XLS-4SF	15.5	40	150	12	21,300
XLS-4SF	15.5	40	200	12	25,100
XLS-4SF	16	40	150	12	17,700
XLS-4SF	16	40	200	12	21,000
XLS-4SF	16.5	40	200	16	28,200
XLS-4SF	16.5	40	250	16	32,100
XLS-4SF	17	40	200	16	23,500
XLS-4SF	17	40	250	16	27,000
XLS-4SF	17.5	40	200	16	28,200
XLS-4SF	17.5	40	250	16	32,100
XLS-4SF	18	40	200	16	23,500
XLS-4SF	18	40	250	16	27,000
XLS-4SF	18.5	45	200	16	32,100
XLS-4SF	18.5	45	250	16	34,900
XLS-4SF	19	45	200	16	27,000
XLS-4SF	19	45	250	16	29,200
XLS-4SF	19.5	45	200	16	32,100
XLS-4SF	19.5	45	250	16	34,900
XLS-4SF	20	45	200	16	27,000
XLS-4SF	20	45	250	16	29,200

型番	刃径 (D)	刃長 (ℓ)	全長 (L)	シャンク径 (d)	標準価格
XLS-4SF	21	45	250	20	32,100
XLS-4SF	21	45	300	20	33,700
XLS-4SF	22	45	250	20	32,100
XLS-4SF	22	45	300	20	33,700
XLS-4SF	23	50	250	20	37,000
XLS-4SF	23	50	300	20	39,700
XLS-4SF	24	50	250	20	37,000
XLS-4SF	24	50	300	20	39,700
XLS-4SF	25	50	250	20	37,000
XLS-4SF	25	50	300	20	41,100
XLS-4SF	26	50	250	25	41,800
XLS-4SF	26	50	300	25	44,400
XLS-4SF	27	55	250	25	49,200
XLS-4SF	27	55	300	25	53,100
XLS-4SF	28	55	250	25	49,200
XLS-4SF	28	55	300	25	53,100
XLS-4SF	29	55	250	25	51,400
XLS-4SF	29	55	300	25	59,200
XLS-4SF	30	55	250	25	51,400
XLS-4SF	30	55	300	25	59,200
XLS-4SF	31	60	250	25	62,000
XLS-4SF	31	60	300	25	64,400
XLS-4SF	32	60	250	25	62,000
XLS-4SF	32	60	300	25	64,400
XLS-4SF	33	60	250	32	74,500
XLS-4SF	33	60	350	32	75,400
XLS-4SF	34	60	250	32	74,500
XLS-4SF	34	60	350	32	75,400
XLS-4SF	35	60	250	32	74,500
XLS-4SF	35	60	350	32	75,400
XLS-4SF	36	65	250	32	82,300
XLS-4SF	36	65	350	32	88,800
XLS-4SF	37	65	250	32	92,200
XLS-4SF	37	65	350	32	94,400
XLS-4SF	38	65	250	32	92,200
XLS-4SF	38	65	350	32	94,400
XLS-4SF	39	65	250	32	99,000
XLS-4SF	39	65	350	32	102,500
XLS-4SF	40	65	250	32	99,000
XLS-4SF	40	65	350	32	102,500
XLS-4SF	42	70	300	32	104,600
XLS-4SF	42	70	350	32	119,700
XLS-4SF	45	70	300	32	109,600
XLS-4SF	45	70	350	32	150,300
XLS-4SF	45	70	300	42	113,900
XLS-4SF	45	70	350	42	156,500
XLS-4SF	50	75	300	32	157,100
XLS-4SF	50	75	350	32	167,300
XLS-4SF	50	75	300	42	163,700
XLS-4SF	50	75	350	42	174,500

(2BE)  
ボールエンドミル 2枚刃  
2-Flute Ball End Mills

SINCE 1935  
F.K.D.®

材質=HSS-Co  
刃数=2枚  
リード角=右捩れ30°  
刃径公差=0~-0.03  
R公差=±0.025

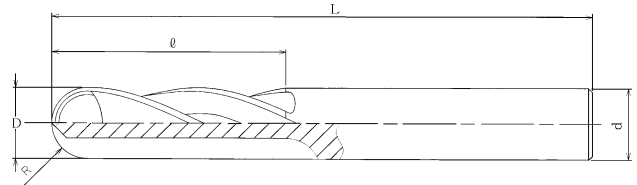
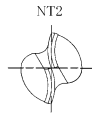

●注文例=型番、R、数量 「2BE 0.5R」 ※26R, 28R, 30Rはシャンク径もご指定下さい。

型番	R	刃径 (D)	刃長 (ℓ)	全長 (L)	シャンク径 (d)	標準価格
2BE	0.5	1	5	60	6	8,500
2BE	0.55	1.1	5	60	6	9,800
2BE	0.6	1.2	5	60	6	9,800
2BE	0.65	1.3	5	60	6	9,800
2BE	0.7	1.4	5	60	6	9,800
2BE	0.75	1.5	5	60	6	9,800
2BE	0.8	1.6	5	60	6	9,800
2BE	0.85	1.7	5	60	6	9,800
2BE	0.9	1.8	5	60	6	9,800
2BE	0.95	1.9	5	60	6	9,800
2BE	1	2	7	60	6	7,800
2BE	1.05	2.1	7	60	6	9,800
2BE	1.1	2.2	7	60	6	9,800
2BE	1.15	2.3	7	60	6	9,800
2BE	1.2	2.4	7	60	6	9,800
2BE	1.25	2.5	10	60	6	9,800
2BE	1.3	2.6	10	60	6	9,800
2BE	1.35	2.7	10	60	6	9,800
2BE	1.4	2.8	10	60	6	9,800
2BE	1.45	2.9	10	60	6	9,800
2BE	1.5	3	15	60	6	7,800
2BE	1.55	3.1	15	60	6	9,800
2BE	1.6	3.2	15	60	6	9,800
2BE	1.65	3.3	15	60	6	9,800
2BE	1.7	3.4	15	60	6	9,800
2BE	1.75	3.5	20	70	6	9,800
2BE	1.8	3.6	20	70	6	9,800
2BE	1.85	3.7	20	70	6	9,800
2BE	1.9	3.8	20	70	6	9,800
2BE	1.95	3.9	20	70	6	9,800
2BE	2	4	20	70	6	7,800
2BE	2.05	4.1	20	70	6	9,800
2BE	2.1	4.2	20	70	6	9,800
2BE	2.15	4.3	20	70	6	9,800
2BE	2.2	4.4	20	70	6	9,800
2BE	2.25	4.5	25	85	6	9,800
2BE	2.3	4.6	25	85	6	9,800
2BE	2.35	4.7	25	85	6	9,800
2BE	2.4	4.8	25	85	6	9,800
2BE	2.45	4.9	25	85	6	9,800
2BE	2.5	5	25	85	6	7,800
2BE	2.55	5.1	25	85	6	9,800
2BE	2.6	5.2	25	85	6	9,800
2BE	2.65	5.3	25	85	6	9,800
2BE	2.7	5.4	25	85	6	9,800
2BE	2.75	5.5	30	90	6	9,800

型番	R	刃径 (D)	刃長 (ℓ)	全長 (L)	シャンク径 (d)	標準価格
2BE	2.8	5.6	30	90	6	9,800
2BE	2.85	5.7	30	90	6	9,800
2BE	2.9	5.8	30	90	6	9,800
2BE	2.95	5.9	30	90	6	9,800
2BE	3	6	30	90	6	7,800
2BE	3.05	6.1	30	90	6	10,900
2BE	3.1	6.2	30	90	8	10,900
2BE	3.15	6.3	30	90	8	10,900
2BE	3.2	6.4	30	90	8	10,900
2BE	3.25	6.5	30	95	8	10,900
2BE	3.3	6.6	30	95	8	10,900
2BE	3.35	6.7	30	95	8	10,900
2BE	3.4	6.8	30	95	8	10,900
2BE	3.45	6.9	30	95	8	10,900
2BE	3.5	7	30	95	8	9,000
2BE	3.55	7.1	30	95	8	10,900
2BE	3.6	7.2	30	95	8	10,900
2BE	3.65	7.3	30	95	8	10,900
2BE	3.7	7.4	30	95	8	10,900
2BE	3.75	7.5	35	100	8	10,900
2BE	3.8	7.6	35	100	8	10,900
2BE	3.85	7.7	35	100	8	10,900
2BE	3.9	7.8	35	100	8	10,900
2BE	3.95	7.9	35	100	8	10,900
2BE	4	8	35	100	8	9,000
2BE	4.05	8.1	35	100	8	13,800
2BE	4.1	8.2	35	100	10	13,800
2BE	4.15	8.3	35	100	10	13,800
2BE	4.2	8.4	35	100	10	13,800
2BE	4.25	8.5	40	115	10	13,800
2BE	4.3	8.6	40	115	10	13,800
2BE	4.35	8.7	40	115	10	13,800
2BE	4.4	8.8	40	115	10	13,800
2BE	4.45	8.9	40	115	10	13,800
2BE	4.5	9	40	115	10	11,600
2BE	4.55	9.1	40	115	10	13,800
2BE	4.6	9.2	40	115	10	13,800
2BE	4.65	9.3	40	115	10	13,800
2BE	4.7	9.4	40	115	10	13,800
2BE	4.75	9.5	40	115	10	13,800
2BE	4.8	9.6	40	115	10	13,800
2BE	4.85	9.7	40	115	10	13,800
2BE	4.9	9.8	40	115	10	13,800
2BE	4.95	9.9	40	115	10	13,800
2BE	5	10	40	115	10	11,600
2BE	5.05	10.1	40	115	10	16,100

(2BE)  
ボールエンドミル 2枚刃  
2-Flute Ball End Mills

SINCE 1935  
F.K.D.®

材質=HSS-Co  
刃数=2枚  
リード角=右捩れ30°  
刃径公差=0~-0.03  
R公差=±0.025

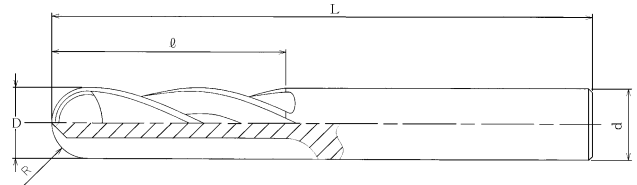
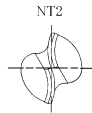

●注文例=型番、R、数量 「2BE 5.1R」 ※26R, 28R, 30Rはシャンク径もご指定下さい。

型番	R	刃径 (D)	刃長 (ℓ)	全長 (L)	シャンク径 (d)	標準価格
2BE	5.1	10.2	40	115	12	16,100
2BE	5.15	10.3	40	115	12	16,100
2BE	5.2	10.4	40	115	12	16,100
2BE	5.25	10.5	45	120	12	16,100
2BE	5.3	10.6	45	120	12	16,100
2BE	5.35	10.7	45	120	12	16,100
2BE	5.4	10.8	45	120	12	16,100
2BE	5.45	10.9	45	120	12	16,100
2BE	5.5	11	45	120	12	12,900
2BE	5.55	11.1	45	120	12	16,100
2BE	5.6	11.2	45	120	12	16,100
2BE	5.65	11.3	45	120	12	16,100
2BE	5.7	11.4	45	120	12	16,100
2BE	5.75	11.5	45	120	12	16,100
2BE	5.8	11.6	45	120	12	16,100
2BE	5.85	11.7	45	120	12	16,100
2BE	5.9	11.8	45	120	12	16,100
2BE	5.95	11.9	45	120	12	16,100
2BE	6	12	45	120	12	12,900
2BE	6.05	12.1	45	120	12	20,500
2BE	6.1	12.2	45	120	12	20,500
2BE	6.15	12.3	45	120	12	20,500
2BE	6.2	12.4	45	120	12	20,500
2BE	6.25	12.5	50	125	12	20,500
2BE	6.3	12.6	50	125	12	20,500
2BE	6.35	12.7	50	125	12	20,500
2BE	6.4	12.8	50	125	12	20,500
2BE	6.45	12.9	50	125	12	20,500
2BE	6.5	13	50	125	12	17,400
2BE	6.55	13.1	50	125	12	20,500
2BE	6.6	13.2	50	125	12	20,500
2BE	6.65	13.3	50	125	12	20,500
2BE	6.7	13.4	50	125	12	20,500
2BE	6.75	13.5	50	125	12	20,500
2BE	6.8	13.6	50	125	12	20,500
2BE	6.85	13.7	50	125	12	20,500
2BE	6.9	13.8	50	125	12	20,500
2BE	6.95	13.9	50	125	12	20,500
2BE	7	14	50	125	12	17,400
2BE	7.05	14.1	50	125	12	25,100
2BE	7.1	14.2	50	125	12	25,100
2BE	7.15	14.3	50	125	12	25,100
2BE	7.2	14.4	50	125	12	25,100
2BE	7.25	14.5	55	135	16	25,100
2BE	7.3	14.6	55	135	16	25,100
2BE	7.35	14.7	55	135	16	25,100

型番	R	刃径 (D)	刃長 (ℓ)	全長 (L)	シャンク径 (d)	標準価格
2BE	7.4	14.8	55	135	16	25,100
2BE	7.45	14.9	55	135	16	25,100
2BE	7.5	15	55	135	16	21,000
2BE	7.55	15.1	55	135	16	25,100
2BE	7.6	15.2	55	135	16	25,100
2BE	7.65	15.3	55	135	16	25,100
2BE	7.7	15.4	55	135	16	25,100
2BE	7.75	15.5	55	135	16	25,100
2BE	7.8	15.6	55	135	16	25,100
2BE	7.85	15.7	55	135	16	25,100
2BE	7.9	15.8	55	135	16	25,100
2BE	7.95	15.9	55	135	16	25,100
2BE	8	16	55	135	16	21,000
2BE	8.05	16.1	55	135	16	28,900
2BE	8.1	16.2	55	135	16	28,900
2BE	8.15	16.3	55	135	16	28,900
2BE	8.2	16.4	55	135	16	28,900
2BE	8.25	16.5	60	145	16	28,900
2BE	8.3	16.6	60	145	16	28,900
2BE	8.35	16.7	60	145	16	28,900
2BE	8.4	16.8	60	145	16	28,900
2BE	8.45	16.9	60	145	16	28,900
2BE	8.5	17	60	145	16	24,100
2BE	8.55	17.1	60	145	16	28,900
2BE	8.6	17.2	60	145	16	28,900
2BE	8.65	17.3	60	145	16	28,900
2BE	8.7	17.4	60	145	16	28,900
2BE	8.75	17.5	60	145	16	28,900
2BE	8.8	17.6	60	145	16	28,900
2BE	8.85	17.7	60	145	16	28,900
2BE	8.9	17.8	60	145	16	28,900
2BE	8.95	17.9	60	145	16	28,900
2BE	9	18	60	145	16	24,100
2BE	9.05	18.1	60	145	16	34,900
2BE	9.1	18.2	60	145	16	34,900
2BE	9.15	18.3	60	145	16	34,900
2BE	9.2	18.4	60	145	16	34,900
2BE	9.25	18.5	65	150	20	34,900
2BE	9.3	18.6	65	150	20	34,900
2BE	9.35	18.7	65	150	20	34,900
2BE	9.4	18.8	65	150	20	34,900
2BE	9.45	18.9	65	150	20	34,900
2BE	9.5	19	65	150	20	29,200
2BE	9.55	19.1	65	150	20	34,900
2BE	9.6	19.2	65	150	20	34,900
2BE	9.65	19.3	65	150	20	34,900

(2BE)  
ボールエンドミル 2枚刃  
2-Flute Ball End Mills

SINCE 1935  
F.K.D.®

材質=HSS-Co  
刃数=2枚  
リード角=右捩れ30°  
刃径公差=0~-0.03  
R公差=±0.025

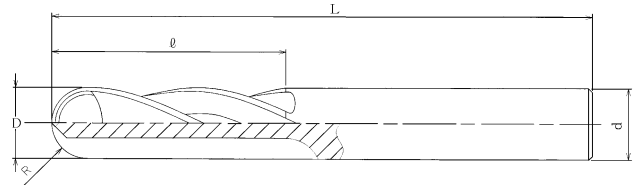
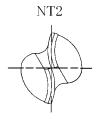

●注文例=型番、R、数量 「2BE 9.7R」 ※26R, 28R, 30Rはシャンク径もご指定下さい。

型番	R	刃径 (D)	刃長 (ℓ)	全長 (L)	シャンク径 (d)	標準価格
2BE	9.7	19.4	65	150	20	34,900
2BE	9.75	19.5	65	150	20	34,900
2BE	9.8	19.6	65	150	20	34,900
2BE	9.85	19.7	65	150	20	34,900
2BE	9.9	19.8	65	150	20	34,900
2BE	9.95	19.9	65	150	20	34,900
2BE	10	20	65	150	20	29,200
2BE	10.05	20.1	65	150	20	38,100
2BE	10.1	20.2	65	150	20	38,100
2BE	10.15	20.3	65	150	20	38,100
2BE	10.2	20.4	65	150	20	38,100
2BE	10.25	20.5	65	150	20	38,100
2BE	10.3	20.6	65	150	20	38,100
2BE	10.35	20.7	65	150	20	38,100
2BE	10.4	20.8	65	150	20	38,100
2BE	10.45	20.9	65	150	20	38,100
2BE	10.5	21	65	150	20	32,000
2BE	10.55	21.1	65	150	20	38,100
2BE	10.6	21.2	65	150	20	38,100
2BE	10.65	21.3	65	150	20	38,100
2BE	10.7	21.4	65	150	20	38,100
2BE	10.75	21.5	65	150	20	38,100
2BE	10.8	21.6	65	150	20	38,100
2BE	10.85	21.7	65	150	20	38,100
2BE	10.9	21.8	65	150	20	38,100
2BE	10.95	21.9	65	150	20	38,100
2BE	11	22	65	150	20	32,000
2BE	11.05	22.1	65	150	20	40,700
2BE	11.1	22.2	65	150	20	40,700
2BE	11.15	22.3	65	150	20	40,700
2BE	11.2	22.4	65	150	20	40,700
2BE	11.25	22.5	70	160	25	40,700
2BE	11.3	22.6	70	160	25	40,700
2BE	11.35	22.7	70	160	25	40,700
2BE	11.4	22.8	70	160	25	40,700
2BE	11.45	22.9	70	160	25	40,700
2BE	11.5	23	70	160	25	34,000
2BE	11.55	23.1	70	160	25	40,700
2BE	11.6	23.2	70	160	25	40,700
2BE	11.65	23.3	70	160	25	40,700
2BE	11.7	23.4	70	160	25	40,700
2BE	11.75	23.5	70	160	25	40,700
2BE	11.8	23.6	70	160	25	40,700
2BE	11.85	23.7	70	160	25	40,700
2BE	11.9	23.8	70	160	25	40,700
2BE	11.95	23.9	70	160	25	40,700

型番	R	刃径 (D)	刃長 (ℓ)	全長 (L)	シャンク径 (d)	標準価格
2BE	12	24	70	160	25	34,000
2BE	12.05	24.1	70	160	25	48,200
2BE	12.1	24.2	70	160	25	48,200
2BE	12.15	24.3	70	160	25	48,200
2BE	12.2	24.4	70	160	25	48,200
2BE	12.25	24.5	70	160	25	48,200
2BE	12.3	24.6	70	160	25	48,200
2BE	12.35	24.7	70	160	25	48,200
2BE	12.4	24.8	70	160	25	48,200
2BE	12.45	24.9	70	160	25	48,200
2BE	12.5	25	70	160	25	39,900
2BE	12.55	25.1	70	160	25	48,200
2BE	12.6	25.2	70	160	25	48,200
2BE	12.65	25.3	70	160	25	48,200
2BE	12.7	25.4	70	160	25	48,200
2BE	12.75	25.5	70	160	25	48,200
2BE	12.8	25.6	70	160	25	48,200
2BE	12.85	25.7	70	160	25	48,200
2BE	12.9	25.8	70	160	25	48,200
2BE	12.95	25.9	70	160	25	48,200
2BE	13	26	70	160	25	39,900
2BE	13.25	26.5	75	165	25	58,200
2BE	13.5	27	75	165	25	48,600
2BE	13.75	27.5	75	165	25	58,200
2BE	14	28	75	165	25	48,600
2BE	14.25	28.5	75	165	25	63,100
2BE	14.5	29	75	165	25	52,600
2BE	14.75	29.5	75	165	25	63,100
2BE	15	30	75	165	25	52,600
2BE	15.5	31	80	180	32	64,000
2BE	16	32	80	180	32	61,500
2BE	16.5	33	80	180	32	72,600
2BE	17	34	80	180	32	69,700
2BE	17.5	35	80	180	32	81,200
2BE	18	36	80	180	32	77,900
2BE	18.5	37	85	185	32	103,500
2BE	19	38	85	185	32	95,800
2BE	19.5	39	85	185	32	113,500
2BE	20	40	85	185	32	103,800
2BE	20.5	41	100	220	32	120,200
2BE	21	42	100	220	32	110,600
2BE	21.5	43	100	220	32	134,100
2BE	22	44	100	220	32	123,000
2BE	22.5	45	100	220	32	149,100
2BE	23	46	100	220	32	136,600
2BE	23.5	47	100	220	32	160,200

(2BE)  
ボールエンドミル 2枚刃  
2-Flute Ball End Mills

SINCE 1935  
F.K.D.®

材質=HSS-Co  
刃数=2枚  
リード角=右捩れ30°  
刃径公差=0~-0.03  
R公差=±0.025

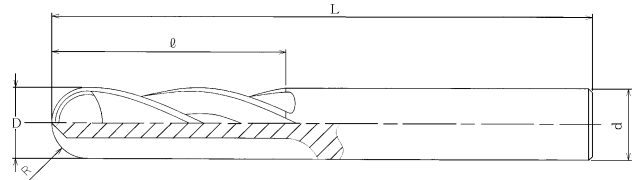
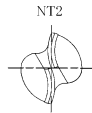

●注文例=型番、R、数量 「2BE 24R」  
※26R, 28R, 30Rはシャンク径もご指定下さい。

型番	R	刃径 (D)	刃長 (l)	全長 (L)	シャンク径 (d)	標準価格
2BE	24	48	100	220	32	146,700
2BE	24.5	49	100	220	32	182,200
2BE	25	50	100	220	32	167,300
2BE	25.5	51	120	240	32	201,700
2BE	26	52	120	240	32	185,000
2BE	26	52	120	240	42	192,800
2BE	26.5	53	120	240	32	211,600
2BE	27	54	120	240	32	194,300
2BE	27.5	55	120	240	32	222,400
2BE	28	56	120	240	32	204,100
2BE	28	56	120	240	42	212,600
2BE	28.5	57	120	240	32	236,800
2BE	29	58	120	240	32	217,500
2BE	29.5	59	120	240	32	264,600
2BE	30	60	120	240	32	242,700
2BE	30	60	120	240	42	252,800
2BE	32.5	65	120	240	32	393,600
2BE	35	70	120	240	32	446,300
2BE	37.5	75	120	240	32	536,400
2BE	40	80	120	240	32	583,800

●注文例=型番、R、数量 「2BE 1/16”R」  
○インチサイズ

型番	R	刃径 (D)	刃長 (l)	全長 (L)	シャンク径 (d)	標準価格
2BE	1/16”	3.175	15	60	6	9,800
2BE	1/8”	6.35	30	90	8	10,900
2BE	3/16”	9.525	40	115	10	13,800
2BE	1/4”	12.7	50	125	12	20,500
2BE	5/16”	15.875	55	135	16	25,100
2BE	3/8”	19.05	65	150	20	34,900
2BE	7/16”	22.225	70	160	25	40,700
2BE	1/2”	25.4	70	160	25	48,200
2BE	9/16”	28.575	75	165	25	63,100
2BE	5/8”	31.75	80	180	32	73,700
2BE	11/16”	34.925	80	180	32	93,400
2BE	3/4”	38.1	85	185	32	130,100
2BE	13/16”	41.275	100	220	32	138,400
2BE	7/8”	44.45	100	220	32	171,100
2BE	15/16”	47.625	100	220	32	184,400
2BE	1”	50.8	120	240	32	232,100



(4BE)  
ボールエンドミル 4枚刃  
4-Flute Ball End Mills

SINCE 1935  
F.K.D.®

材質=HSS-Co  
刃数=4枚  
リード角=右振れ30°  
刃径公差=0~-0.03  
R公差=±0.025

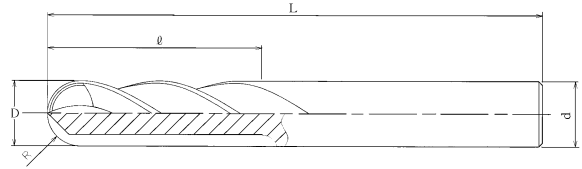

●注文例=型番、R、数量 「4BE 2R」

型番	R	刃径 (D)	刃長 (ℓ)	全長 (L)	シャンク径 (d)	標準価格
4BE	2	4	20	70	6	8,900
4BE	2.5	5	25	85	6	8,900
4BE	3	6	30	90	6	8,900
4BE	3.5	7	30	95	8	10,000
4BE	4	8	35	100	8	10,000
4BE	4.5	9	40	115	10	12,700
4BE	5	10	40	115	10	12,700
4BE	5.5	11	45	120	12	14,300
4BE	6	12	45	120	12	14,300
4BE	6.5	13	50	125	12	18,700
4BE	7	14	50	125	12	18,700
4BE	7.5	15	55	135	16	22,900
4BE	8	16	55	135	16	22,900
4BE	8.5	17	60	145	16	26,400
4BE	9	18	60	145	16	26,400
4BE	9.5	19	65	150	20	32,100
4BE	10	20	65	150	20	32,100
4BE	10.5	21	65	150	20	35,200
4BE	11	22	65	150	20	35,200
4BE	11.5	23	70	160	25	37,400
4BE	12	24	70	160	25	37,400
4BE	12.5	25	70	160	25	44,000
4BE	13	26	70	160	25	44,000
4BE	13.5	27	75	165	25	53,400
4BE	14	28	75	165	25	53,400
4BE	14.5	29	75	165	25	58,000
4BE	15	30	75	165	25	58,000
4BE	15.5	31	80	180	32	67,800
4BE	16	32	80	180	32	67,800

型番	R	刃径 (D)	刃長 (ℓ)	全長 (L)	シャンク径 (d)	標準価格
4BE	16.5	33	80	180	32	76,800
4BE	17	34	80	180	32	76,800
4BE	17.5	35	80	180	32	85,700
4BE	18	36	80	180	32	85,700
4BE	18.5	37	85	185	32	108,900
4BE	19	38	85	185	32	105,200
4BE	19.5	39	85	185	32	124,700
4BE	20	40	85	185	32	114,200
4BE	20.5	41	100	220	32	132,200
4BE	21	42	100	220	32	121,600
4BE	21.5	43	100	220	32	147,600
4BE	22	44	100	220	32	135,500
4BE	22.5	45	100	220	32	163,700
4BE	23	46	100	220	32	150,300
4BE	24	48	100	220	32	161,700
4BE	25	50	100	220	32	184,400
4BE	26	52	120	240	32	203,800
4BE	27	54	120	240	32	214,000
4BE	27.5	55	120	240	32	233,900
4BE	28	56	120	240	32	224,600
4BE	29	58	120	240	32	239,400
4BE	30	60	120	240	32	266,600

○インチサイズ

●注文例=型番、R、数量 「4BE 1/4"R」

型番	R	刃径 (D)	刃長 (ℓ)	全長 (L)	シャンク径 (d)	標準価格
4BE	1/4"	12.7	50	125	12	22,700
4BE	5/16"	15.875	55	135	16	27,300
4BE	3/8"	19.05	65	150	20	38,500
4BE	1/2"	25.4	70	160	25	52,800
4BE	5/8"	31.75	80	180	32	81,200

(2LS-BE)  
**ロングシャンクボールエンドミル 2枚刃**  
 2-Flute Long Shank Ball End Mills

SINCE 1935  
**F.K.D.**®

材質=HSS-Co  
 刃数=2枚  
 リード角=右捩れ30°  
 刃径公差=0~-0.03  
 R公差=±0.025

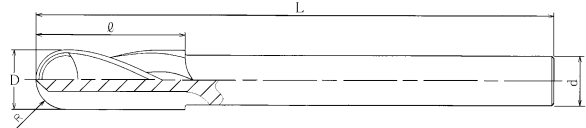

●注文例=型番、R、数量 「2LS-BE 3R」

型番	R	刃径 (D)	刃長 (ℓ)	全長 (L)	シャンク径 (d)	標準価格
2LS-BE	3	6	30	130	6	14,400
2LS-BE	3.25	6.5	35	130	6	17,700
2LS-BE	3.5	7	35	130	6	14,900
2LS-BE	3.75	7.5	35	130	8	18,700
2LS-BE	4	8	35	130	8	15,500
2LS-BE	4.25	8.5	40	130	8	20,000
2LS-BE	4.5	9	40	130	8	16,600
2LS-BE	4.75	9.5	40	130	10	21,300
2LS-BE	5	10	40	170	10	17,700
2LS-BE	5.25	10.5	45	170	10	23,500
2LS-BE	5.5	11	45	170	10	19,500
2LS-BE	5.75	11.5	45	170	12	25,900
2LS-BE	6	12	45	170	12	21,600
2LS-BE	6.25	12.5	50	170	12	27,100
2LS-BE	6.5	13	50	170	12	22,700
2LS-BE	6.75	13.5	50	170	12	28,800
2LS-BE	7	14	50	170	12	23,900
2LS-BE	7.25	14.5	55	170	12	30,900
2LS-BE	7.5	15	55	170	12	25,900
2LS-BE	7.75	15.5	55	170	16	32,300
2LS-BE	8	16	55	220	16	27,000
2LS-BE	8.25	16.5	60	220	16	34,200

型番	R	刃径 (D)	刃長 (ℓ)	全長 (L)	シャンク径 (d)	標準価格
2LS-BE	8.5	17	60	220	16	28,400
2LS-BE	8.75	17.5	60	220	16	35,300
2LS-BE	9	18	60	220	16	29,400
2LS-BE	9.25	18.5	65	220	16	40,700
2LS-BE	9.5	19	65	220	16	34,000
2LS-BE	9.75	19.5	65	220	20	42,700
2LS-BE	10	20	65	260	20	35,600
2LS-BE	10.25	20.5	65	260	20	49,700
2LS-BE	10.5	21	65	260	20	49,700
2LS-BE	10.75	21.5	65	260	20	49,700
2LS-BE	11	22	65	260	20	41,500
2LS-BE	11.5	23	65	260	20	54,200
2LS-BE	12	24	70	260	20	45,400
2LS-BE	12.5	25	70	260	25	52,300
2LS-BE	13	26	70	260	25	52,600
2LS-BE	13.5	27	70	260	25	74,300
2LS-BE	14	28	75	260	25	62,000
2LS-BE	14.5	29	75	260	25	85,100
2LS-BE	15	30	75	260	25	71,000
2LS-BE	16	32	80	300	32	85,900
2LS-BE	20	40	100	320	32	132,600

(4LS-BE)  
**ロングシャンクボールエンドミル 4枚刃**  
 4-Flute Long Shank Ball End Mills

材質=HSS-Co  
 刃数=4枚  
 リード角=右捩れ30°  
 刃径公差=0~-0.03  
 R公差=±0.025

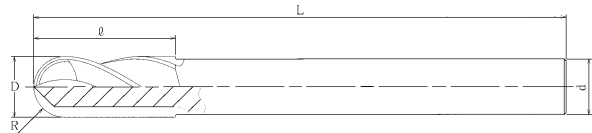

●注文例=型番、R、数量 「4LS-BE 15.5R」

型番	R	刃径 (D)	刃長 (ℓ)	全長 (L)	シャンク径 (d)	標準価格
4LS-BE	15.5	31	80	300	32	98,100
4LS-BE	16	32	80	300	32	94,400
4LS-BE	16.5	33	80	300	32	112,100
4LS-BE	17	34	80	300	32	107,600
4LS-BE	17.5	35	80	300	32	115,300
4LS-BE	18	36	80	300	32	117,700
4LS-BE	18.5	37	80	300	32	137,700
4LS-BE	19	38	100	320	32	132,200

型番	R	刃径 (D)	刃長 (ℓ)	全長 (L)	シャンク径 (d)	標準価格
4LS-BE	19.5	39	100	320	32	151,900
4LS-BE	20	40	100	320	32	145,800
4LS-BE	21	42	100	320	42	163,900
4LS-BE	22	44	100	320	42	184,400
4LS-BE	22.5	45	125	320	42	208,600
4LS-BE	23	46	125	320	42	214,900
4LS-BE	24	48	125	320	42	225,100
4LS-BE	25	50	125	320	42	246,500

(XLS-BE) 2-Flute Extra Long Shank Ball End Mills  
**特ロングシャンクボールエンドミル 2枚刃**

SINCE 1935  
**F.K.D.**®

材質=HSS-Co  
 リード角=右振れ30°  
 R公差=±0.025

刃数=2枚  
 刃径公差=0~-0.03

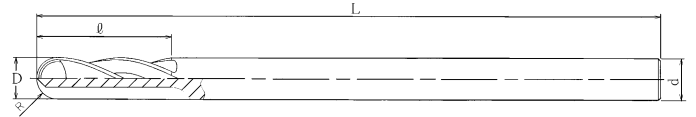

●注文例=型番、R、数量 「XLS-BE 3R」

型番	R	刃径 (D)	刃長 (ℓ)	全長 (L)	シャンク径 (d)	標準価格
XLS-BE	3	6	30	150	6	16,600
XLS-BE	3.5	7	35	150	6	17,500
XLS-BE	4	8	35	150	8	18,500
XLS-BE	4.5	9	40	150	8	20,400
XLS-BE	5	10	40	200	10	20,200
XLS-BE	5.5	11	45	200	10	22,700
XLS-BE	6	12	45	200	12	21,700
XLS-BE	6.5	13	50	200	12	27,100
XLS-BE	7	14	50	200	12	27,100
XLS-BE	7.5	15	55	200	12	29,400
XLS-BE	8	16	55	250	16	32,800

型番	R	刃径 (D)	刃長 (ℓ)	全長 (L)	シャンク径 (d)	標準価格
XLS-BE	8.5	17	60	250	16	34,200
XLS-BE	9	18	60	250	16	36,900
XLS-BE	9.5	19	65	250	16	41,600
XLS-BE	10	20	65	300	20	44,400
XLS-BE	11	22	65	300	20	44,400
XLS-BE	12	24	70	300	20	52,300
XLS-BE	12.5	25	70	300	25	61,800
XLS-BE	13	26	70	300	25	59,200
XLS-BE	14	28	75	300	25	71,900
XLS-BE	15	30	75	300	25	82,900

(LF-BE) 2-Flute Long Flute Ball End Mills  
**ロング刃ボールエンドミル 2枚刃**

材質=HSS-Co  
 リード角=右振れ30°  
 R公差=±0.025

刃数=2枚  
 刃径公差=0~-0.03

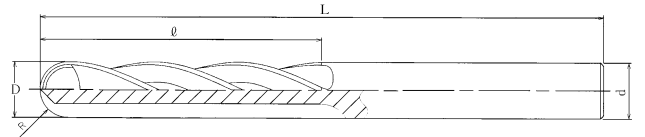

●注文例=型番、R、数量 「LF-BE 3R」

型番	R	刃径 (D)	刃長 (ℓ)	全長 (L)	シャンク径 (d)	標準価格
LF-BE	3	6	50	150	6	16,600
LF-BE	3.5	7	50	150	6	17,500
LF-BE	4	8	50	150	8	18,500
LF-BE	4.5	9	50	150	8	19,300
LF-BE	5	10	60	150	10	20,200
LF-BE	5.5	11	60	150	10	21,100
LF-BE	6	12	60	150	12	23,100
LF-BE	6.5	13	70	150	12	29,400
LF-BE	7	14	70	150	12	30,300
LF-BE	7.5	15	80	200	12	34,900
LF-BE	8	16	100	200	16	38,900
LF-BE	8.5	17	100	200	16	42,700

型番	R	刃径 (D)	刃長 (ℓ)	全長 (L)	シャンク径 (d)	標準価格
LF-BE	9	18	100	200	16	44,800
LF-BE	9.5	19	100	200	16	46,900
LF-BE	10	20	100	200	20	52,400
LF-BE	10.5	21	100	200	20	56,000
LF-BE	11	22	120	250	20	59,500
LF-BE	11.5	23	150	250	20	73,400
LF-BE	12	24	150	250	20	75,400
LF-BE	12.5	25	150	250	25	88,900
LF-BE	15	30	150	300	25	106,500
LF-BE	17.5	35	150	350	32	149,500
LF-BE	20	40	150	350	32	195,100

(NBE) Tapered Neck Ball End Mills  
**テーパードネックボールエンドミル**

材質=粉末ハイス  
 リード角=右振れ30°  
 R公差=±0.025

刃数=R ≤ 12.5 (2枚刃)  
 R ≥ 15 (4枚刃)  
 刃径公差=0~-0.05

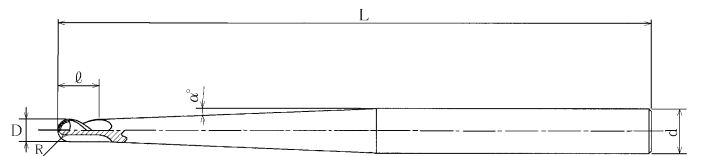

●注文例=型番、R、数量 「NBE 1.5R」

型番	R	刃径 (D)	刃長 (ℓ)	全長 (L)	シャンク径 (d)	標準価格
NBE	1.5	3	8	160	10	16,300
NBE	2	4	8	180	12	16,300
NBE	2.5	5	10	200	12	16,300
NBE	3	6	12	220	16	17,600
NBE	4	8	14	245	16	18,600
NBE	5	10	18	260	20	26,600
NBE	6	12	22	280	25	35,100

型番	R	刃径 (D)	刃長 (ℓ)	全長 (L)	シャンク径 (d)	標準価格
NBE	7	14	26	300	25	36,900
NBE	8	16	30	300	32	60,900
NBE	9	18	34	350	32	69,200
NBE	10	20	38	350	32	69,200
NBE	12.5	25	50	350	32	122,200
NBE	15	30	55	350	42	134,400
NBE	20	40	65	400	42	195,600

(2RBE)  
ラジアスエンドミル 2枚刃  
2-Flute Radius Ball End Mills

SINCE 1935  
F.K.D.®

材質=HSS-Co  
刃数=2枚  
リード角=右捩れ30°  
刃径公差=0~-0.03  
R公差=±0.025

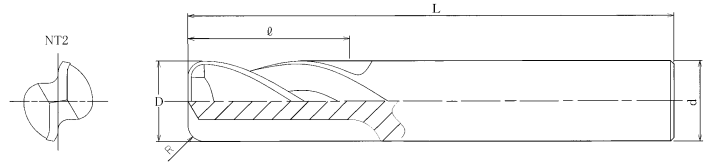

●注文例=型番、刃径、R、数量 「2RBE 3x0.5R」

型番	刃径 (D)	R	刃長 (ℓ)	全長 (L)	シャンク径 (d)	標準価格
2RBE	3	0.5	10	53	6	6,800
2RBE	3	0.75	10	53	6	6,800
2RBE	3	1	10	53	6	6,800
2RBE	4	0.5	12	59	6	6,800
2RBE	4	0.75	12	59	6	6,800
2RBE	4	1	12	59	6	6,800
2RBE	5	0.5	14	59	6	6,800
2RBE	5	0.75	14	59	6	6,800
2RBE	5	1	14	59	6	6,800
2RBE	5	1.5	14	59	6	6,800
2RBE	6	0.5	16	59	6	6,200
2RBE	6	0.75	16	59	6	6,200
2RBE	6	1	16	59	6	6,200
2RBE	6	1.5	16	59	6	6,200
2RBE	6	2	16	59	6	6,200
2RBE	7	0.5	18	59	6	7,800
2RBE	7	0.75	18	59	6	7,800
2RBE	7	1	18	59	6	7,800
2RBE	7	1.5	18	59	6	7,800
2RBE	7	2	18	59	6	7,800
2RBE	8	0.5	20	75	8	6,800
2RBE	8	0.75	20	75	8	6,800
2RBE	8	1	20	75	8	6,800
2RBE	8	1.5	20	75	8	6,800
2RBE	8	2	20	75	8	6,800
2RBE	8	2.5	20	75	8	6,800
2RBE	8	3	20	75	8	6,800
2RBE	9	0.5	22	80	10	9,900
2RBE	9	0.75	22	80	10	9,900
2RBE	9	1	22	80	10	9,900
2RBE	9	1.5	22	80	10	9,900
2RBE	9	2	22	80	10	9,900
2RBE	9	2.5	22	80	10	9,900
2RBE	9	3	22	80	10	9,900
2RBE	10	0.5	25	80	10	7,900
2RBE	10	0.75	25	80	10	7,900
2RBE	10	1	25	80	10	7,900
2RBE	10	1.5	25	80	10	7,900
2RBE	10	2	25	80	10	7,900
2RBE	10	2.5	25	80	10	7,900
2RBE	10	3	25	80	10	7,900
2RBE	11	0.5	28	90	12	10,700
2RBE	11	0.75	28	90	12	10,700
2RBE	11	1	28	90	12	10,700
2RBE	11	1.5	28	90	12	10,700
2RBE	11	2	28	90	12	10,700

型番	刃径 (D)	R	刃長 (ℓ)	全長 (L)	シャンク径 (d)	標準価格
2RBE	11	2.5	28	90	12	10,700
2RBE	11	3	28	90	12	10,700
2RBE	11	4	28	90	12	10,700
2RBE	12	0.5	30	90	12	9,600
2RBE	12	0.75	30	90	12	9,600
2RBE	12	1	30	90	12	9,600
2RBE	12	1.5	30	90	12	9,600
2RBE	12	2	30	90	12	9,600
2RBE	12	2.5	30	90	12	9,600
2RBE	12	3	30	90	12	9,600
2RBE	12	4	30	90	12	9,600
2RBE	12	5	30	90	12	9,600
2RBE	13	0.5	35	100	12	14,200
2RBE	13	0.75	35	100	12	14,200
2RBE	13	1	35	100	12	14,200
2RBE	13	1.5	35	100	12	14,200
2RBE	13	2	35	100	12	14,200
2RBE	13	2.5	35	100	12	14,200
2RBE	13	3	35	100	12	14,200
2RBE	13	4	35	100	12	14,200
2RBE	13	5	35	100	12	14,200
2RBE	14	0.5	35	100	12	14,200
2RBE	14	0.75	35	100	12	14,200
2RBE	14	1	35	100	12	14,200
2RBE	14	1.5	35	100	12	14,200
2RBE	14	2	35	100	12	14,200
2RBE	14	2.5	35	100	12	14,200
2RBE	14	3	35	100	12	14,200
2RBE	14	4	35	100	12	14,200
2RBE	14	5	35	100	12	14,200
2RBE	15	0.5	40	105	16	12,700
2RBE	15	0.75	40	105	16	12,700
2RBE	15	1	40	105	16	12,700
2RBE	15	1.5	40	105	16	12,700
2RBE	15	2	40	105	16	13,800
2RBE	15	2.5	40	105	16	13,800
2RBE	15	3	40	105	16	13,800
2RBE	15	4	40	105	16	15,000
2RBE	15	5	40	105	16	15,000
2RBE	16	0.5	40	105	16	13,600
2RBE	16	0.75	40	105	16	13,600
2RBE	16	1	40	105	16	13,600
2RBE	16	1.5	40	105	16	13,600
2RBE	16	2	40	105	16	13,600
2RBE	16	2.5	40	105	16	13,600
2RBE	16	3	40	105	16	13,600

# (2RBE) ラジアスエンドミル 2枚刃

2-Flute Radius Ball End Mills

SINCE 1935  
F.K.D.®

材質=HSS-Co  
刃数=2枚  
リード角=右捩れ30°  
刃径公差=0~-0.03  
R公差=±0.025

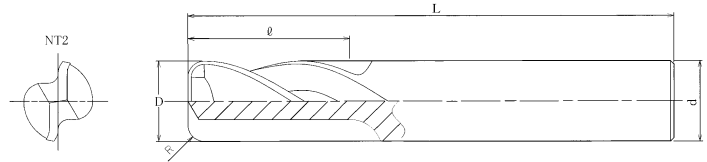

●注文例=型番、刃径、R、数量 「2RBE 16x4R」

型番	刃径 (D)	R	刃長 (ℓ)	全長 (L)	シャンク径 (d)	標準価格
2RBE	16	4	40	105	16	15,500
2RBE	16	5	40	105	16	15,500
2RBE	16	6	40	105	16	15,500
2RBE	18	0.5	40	115	16	16,300
2RBE	18	0.75	40	115	16	16,300
2RBE	18	1	40	115	16	16,300
2RBE	18	1.5	40	115	16	16,300
2RBE	18	2	40	115	16	17,700
2RBE	18	2.5	40	115	16	17,700
2RBE	18	3	40	115	16	17,700
2RBE	18	4	40	115	16	17,700
2RBE	18	5	40	115	16	17,700
2RBE	18	6	40	115	16	17,700
2RBE	20	0.5	45	130	20	18,600
2RBE	20	0.75	45	130	20	18,600
2RBE	20	1	45	130	20	18,600
2RBE	20	1.5	45	130	20	18,600
2RBE	20	2	45	130	20	18,600
2RBE	20	2.5	45	130	20	18,600
2RBE	20	3	45	130	20	18,600
2RBE	20	4	45	130	20	20,400
2RBE	20	5	45	130	20	20,400
2RBE	20	6	45	130	20	20,400
2RBE	22	0.5	45	135	20	23,700
2RBE	22	0.75	45	135	20	23,700
2RBE	22	1	45	135	20	23,700
2RBE	22	1.5	45	135	20	23,700
2RBE	22	2	45	135	20	25,000
2RBE	22	2.5	45	135	20	25,000
2RBE	22	3	45	135	20	25,000
2RBE	22	4	45	135	20	26,800
2RBE	22	5	45	135	20	26,800
2RBE	22	6	45	135	20	26,800
2RBE	24	0.5	50	145	25	28,700
2RBE	24	0.75	50	145	25	28,700
2RBE	24	1	50	145	25	28,700
2RBE	24	1.5	50	145	25	28,700
2RBE	24	2	50	145	25	30,400
2RBE	24	2.5	50	145	25	30,400
2RBE	24	3	50	145	25	30,400
2RBE	24	4	50	145	25	34,000
2RBE	24	5	50	145	25	34,000
2RBE	24	6	50	145	25	34,000
2RBE	24	8	50	145	25	34,000
2RBE	25	0.5	50	150	25	25,000
2RBE	25	0.75	50	150	25	25,000

型番	刃径 (D)	R	刃長 (ℓ)	全長 (L)	シャンク径 (d)	標準価格
2RBE	25	1	50	150	25	25,000
2RBE	25	1.5	50	150	25	25,000
2RBE	25	2	50	150	25	25,000
2RBE	25	2.5	50	150	25	25,000
2RBE	25	3	50	150	25	25,000
2RBE	25	4	50	150	25	25,000
2RBE	25	5	50	150	25	25,000
2RBE	25	6	50	150	25	28,700
2RBE	25	8	50	150	25	28,700
2RBE	26	0.5	50	150	25	31,100
2RBE	26	0.75	50	150	25	31,100
2RBE	26	1	50	150	25	31,100
2RBE	26	1.5	50	150	25	31,100
2RBE	26	2	50	150	25	34,000
2RBE	26	2.5	50	150	25	34,000
2RBE	26	3	50	150	25	34,000
2RBE	26	4	50	150	25	38,000
2RBE	26	5	50	150	25	38,000
2RBE	26	6	50	150	25	41,500
2RBE	26	8	50	150	25	41,500
2RBE	26	10	50	150	25	41,500
2RBE	28	0.5	55	155	25	35,600
2RBE	28	0.75	55	155	25	35,600
2RBE	28	1	55	155	25	35,600
2RBE	28	1.5	55	155	25	35,600
2RBE	28	2	55	155	25	38,000
2RBE	28	2.5	55	155	25	38,000
2RBE	28	3	55	155	25	38,000
2RBE	28	4	55	155	25	41,500
2RBE	28	5	55	155	25	41,500
2RBE	28	6	55	155	25	43,300
2RBE	28	8	55	155	25	43,300
2RBE	28	10	55	155	25	43,300
2RBE	30	0.5	55	160	25	35,600
2RBE	30	0.75	55	160	25	35,600
2RBE	30	1	55	160	25	35,600
2RBE	30	1.5	55	160	25	35,600
2RBE	30	2	55	160	25	38,000
2RBE	30	2.5	55	160	25	38,000
2RBE	30	3	55	160	25	38,000
2RBE	30	4	55	160	25	41,500
2RBE	30	5	55	160	25	41,500
2RBE	30	6	55	160	25	43,300
2RBE	30	8	55	160	25	43,300
2RBE	30	10	55	160	25	43,300
2RBE	32	0.5	60	160	32	50,100

(2RBE)  
ラジアスエンドミル 2枚刃  
2-Flute Radius Ball End Mills

SINCE 1935  
F.K.D.®

材質=HSS-Co  
刃数=2枚  
リード角=右振り30°  
刃径公差=0~-0.03  
R公差=±0.025

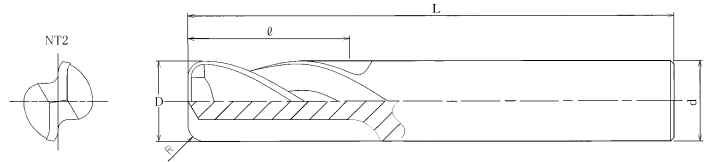

●注文例=型番、刃径、R、数量 「2RBE 32x0.75R」

型番	刃径 (D)	R	刃長 (ℓ)	全長 (L)	シャンク径 (d)	標準価格
2RBE	32	0.75	60	160	32	50,100
2RBE	32	1	60	160	32	50,100
2RBE	32	1.5	60	160	32	50,100
2RBE	32	2	60	160	32	50,100
2RBE	32	2.5	60	160	32	53,400
2RBE	32	3	60	160	32	53,400
2RBE	32	4	60	160	32	57,200
2RBE	32	5	60	160	32	57,200
2RBE	32	6	60	160	32	57,200
2RBE	32	8	60	160	32	60,700
2RBE	32	10	60	160	32	60,700
2RBE	35	0.5	60	175	32	54,700
2RBE	35	0.75	60	175	32	54,700
2RBE	35	1	60	175	32	54,700
2RBE	35	1.5	60	175	32	54,700
2RBE	35	2	60	175	32	56,500
2RBE	35	2.5	60	175	32	56,500
2RBE	35	3	60	175	32	56,500
2RBE	35	4	60	175	32	60,700

型番	刃径 (D)	R	刃長 (ℓ)	全長 (L)	シャンク径 (d)	標準価格
2RBE	35	5	60	175	32	60,700
2RBE	35	6	60	175	32	60,700
2RBE	35	8	60	175	32	64,000
2RBE	35	10	60	175	32	64,000
2RBE	35	12	60	175	32	64,000
2RBE	40	0.5	65	180	32	75,700
2RBE	40	0.75	65	180	32	75,700
2RBE	40	1	65	180	32	75,700
2RBE	40	1.5	65	180	32	75,700
2RBE	40	2	65	180	32	79,500
2RBE	40	2.5	65	180	32	79,500
2RBE	40	3	65	180	32	79,500
2RBE	40	4	65	180	32	83,200
2RBE	40	5	65	180	32	83,200
2RBE	40	6	65	180	32	83,200
2RBE	40	8	65	180	32	87,000
2RBE	40	10	65	180	32	87,000
2RBE	40	12	65	180	32	87,000

# (4RBE) ラジアスエンドミル 4枚刃 4-Flute Radius Ball End Mills

SINCE 1935  
F.K.D.®

材質=HSS-Co  
刃数=4枚  
リード角=右捩れ30°  
刃径公差=0~-0.03  
R公差=±0.025

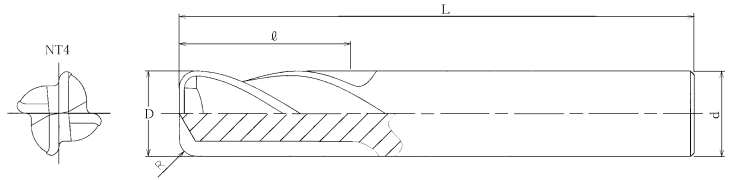

●注文例=型番、刃径、R、数量 「4RBE 6x0.5R」

型番	刃径 (D)	R	刃長 (ℓ)	全長 (L)	シャンク径 (d)	標準価格
4RBE	6	0.5	16	59	6	6,800
4RBE	6	0.75	16	59	6	6,800
4RBE	6	1	16	59	6	6,800
4RBE	6	1.5	16	59	6	6,800
4RBE	6	2	16	59	6	6,800
4RBE	8	0.5	20	75	8	7,600
4RBE	8	0.75	20	75	8	7,600
4RBE	8	1	20	75	8	7,600
4RBE	8	1.5	20	75	8	7,600
4RBE	8	2	20	75	8	7,600
4RBE	8	2.5	20	75	8	7,600
4RBE	8	3	20	75	8	7,600
4RBE	10	0.5	25	80	10	8,900
4RBE	10	0.75	25	80	10	8,900
4RBE	10	1	25	80	10	8,900
4RBE	10	1.5	25	80	10	8,900
4RBE	10	2	25	80	10	8,900
4RBE	10	2.5	25	80	10	8,900
4RBE	10	3	25	80	10	8,900
4RBE	12	0.5	30	90	12	10,500
4RBE	12	0.75	30	90	12	10,500
4RBE	12	1	30	90	12	10,500
4RBE	12	1.5	30	90	12	10,500
4RBE	12	2	30	90	12	10,500
4RBE	12	2.5	30	90	12	10,500
4RBE	12	3	30	90	12	10,500
4RBE	12	3.5	30	90	12	10,500
4RBE	12	4	30	90	12	10,500
4RBE	12	5	30	90	12	10,500
4RBE	14	0.5	35	100	12	15,400
4RBE	14	0.75	35	100	12	15,400
4RBE	14	1	35	100	12	15,400
4RBE	14	1.5	35	100	12	15,400
4RBE	14	2	35	100	12	15,400
4RBE	14	2.5	35	100	12	15,400
4RBE	14	3	35	100	12	15,400
4RBE	14	4	35	100	12	15,400
4RBE	14	5	35	100	12	15,400
4RBE	15	0.5	40	105	16	13,800
4RBE	15	0.75	40	105	16	13,800
4RBE	15	1	40	105	16	13,800
4RBE	15	1.5	40	105	16	13,800
4RBE	15	2	40	105	16	15,300
4RBE	15	2.5	40	105	16	15,300
4RBE	15	3	40	105	16	15,300
4RBE	15	4	40	105	16	16,600

型番	刃径 (D)	R	刃長 (ℓ)	全長 (L)	シャンク径 (d)	標準価格
4RBE	15	5	40	105	16	16,600
4RBE	16	0.5	40	105	16	15,000
4RBE	16	0.75	40	105	16	15,000
4RBE	16	1	40	105	16	15,000
4RBE	16	1.5	40	105	16	15,000
4RBE	16	2	40	105	16	15,000
4RBE	16	2.5	40	105	16	15,000
4RBE	16	3	40	105	16	15,000
4RBE	16	4	40	105	16	16,700
4RBE	16	5	40	105	16	16,700
4RBE	16	6	40	105	16	16,700
4RBE	20	0.5	45	130	20	20,400
4RBE	20	0.75	45	130	20	20,400
4RBE	20	1	45	130	20	20,400
4RBE	20	1.5	45	130	20	20,400
4RBE	20	2	45	130	20	20,400
4RBE	20	2.5	45	130	20	20,400
4RBE	20	3	45	130	20	20,400
4RBE	20	4	45	130	20	22,400
4RBE	20	5	45	130	20	22,400
4RBE	20	6	45	130	20	22,400
4RBE	22	0.5	45	135	20	26,100
4RBE	22	0.75	45	135	20	26,100
4RBE	22	1	45	135	20	26,100
4RBE	22	1.5	45	135	20	26,100
4RBE	22	2	45	135	20	27,000
4RBE	22	2.5	45	135	20	27,000
4RBE	22	3	45	135	20	27,000
4RBE	22	4	45	135	20	29,400
4RBE	22	5	45	135	20	29,400
4RBE	22	6	45	135	20	29,400
4RBE	25	0.5	50	150	25	27,000
4RBE	25	0.75	50	150	25	27,000
4RBE	25	1	50	150	25	27,000
4RBE	25	1.5	50	150	25	27,000
4RBE	25	2	50	150	25	27,000
4RBE	25	2.5	50	150	25	27,000
4RBE	25	3	50	150	25	27,000
4RBE	25	4	50	150	25	27,000
4RBE	25	5	50	150	25	27,000
4RBE	25	6	50	150	25	31,400
4RBE	25	8	50	150	25	31,400
4RBE	26	0.5	50	150	25	34,200
4RBE	26	0.75	50	150	25	34,200
4RBE	26	1	50	150	25	34,200
4RBE	26	1.5	50	150	25	34,200

# (4RBE) ラジアスエンドミル 4枚刃

4-Flute Radius Ball End Mills

SINCE 1935  
F.K.D.®

材質=HSS-Co  
刃数=4枚  
リード角=右振り30°  
刃径公差=0~-0.03  
R公差=±0.025

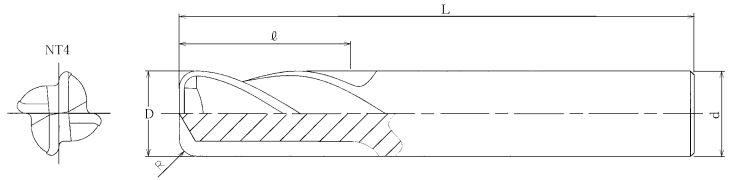

●注文例=型番、刃径、R、数量 「4RBE 26x2R」

型番	刃径 (D)	R	刃長 (ϕ)	全長 (L)	シャンク径 (d)	標準価格
4RBE	26	2	50	150	25	37,100
4RBE	26	2.5	50	150	25	37,100
4RBE	26	3	50	150	25	37,100
4RBE	26	4	50	150	25	41,600
4RBE	26	5	50	150	25	41,600
4RBE	26	6	50	150	25	45,500
4RBE	26	8	50	150	25	45,500
4RBE	28	0.5	55	155	25	39,500
4RBE	28	0.75	55	155	25	39,500
4RBE	28	1	55	155	25	39,500
4RBE	28	1.5	55	155	25	39,500
4RBE	28	2	55	155	25	41,600
4RBE	28	2.5	55	155	25	41,600
4RBE	28	3	55	155	25	41,600
4RBE	28	4	55	155	25	45,500
4RBE	28	5	55	155	25	45,500
4RBE	28	6	55	155	25	47,900
4RBE	28	8	55	155	25	47,900
4RBE	28	10	55	155	25	47,900
4RBE	30	0.5	55	160	25	39,500
4RBE	30	0.75	55	160	25	39,500
4RBE	30	1	55	160	25	39,500
4RBE	30	1.5	55	160	25	39,500
4RBE	30	2	55	160	25	41,600
4RBE	30	2.5	55	160	25	41,600
4RBE	30	3	55	160	25	41,600
4RBE	30	4	55	160	25	45,500
4RBE	30	5	55	160	25	45,500
4RBE	30	6	55	160	25	47,900
4RBE	30	8	55	160	25	47,900
4RBE	30	10	55	160	25	47,900
4RBE	32	1	60	160	32	54,700

型番	刃径 (D)	R	刃長 (ϕ)	全長 (L)	シャンク径 (d)	標準価格
4RBE	32	1.5	60	160	32	54,700
4RBE	32	2	60	160	32	54,700
4RBE	32	2.5	60	160	32	59,000
4RBE	32	3	60	160	32	59,000
4RBE	32	4	60	160	32	62,700
4RBE	32	5	60	160	32	62,700
4RBE	32	6	60	160	32	62,700
4RBE	32	8	60	160	32	66,700
4RBE	32	10	60	160	32	66,700
4RBE	35	1	60	175	32	60,400
4RBE	35	1.5	60	175	32	60,400
4RBE	35	2	60	175	32	62,400
4RBE	35	2.5	60	175	32	62,400
4RBE	35	3	60	175	32	62,400
4RBE	35	4	60	175	32	66,700
4RBE	35	5	60	175	32	66,700
4RBE	35	6	60	175	32	66,700
4RBE	35	8	60	175	32	70,600
4RBE	35	10	60	175	32	70,600
4RBE	35	12	60	175	32	70,600
4RBE	40	1	65	180	32	83,200
4RBE	40	1.5	65	180	32	83,200
4RBE	40	2	65	180	32	87,500
4RBE	40	2.5	65	180	32	87,500
4RBE	40	3	65	180	32	87,500
4RBE	40	4	65	180	32	91,300
4RBE	40	5	65	180	32	91,300
4RBE	40	6	65	180	32	91,300
4RBE	40	8	65	180	32	95,600
4RBE	40	10	65	180	32	95,600
4RBE	40	12	65	180	32	95,600



(CRE)  
 コーナーラウンディングエンドミル  
 Corner Rounding End Mills

SINCE 1935  
 F.K.D.®

材質=HSS  
 刃数=4枚  
 外径公差=+0.15~+0.20  
 先端公差=0~-0.1  
 R公差=0~+0.05  
 X,Y公差=0~+0.1

(R)部の先端、外径方向逃げ無し

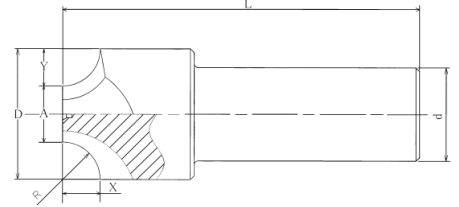
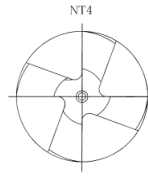

●注文例=型番、R、数量 「CRE 0.5R」

型番	R	外径 (D)	先端径 (A)	全長 (L)	シャンク径 (d)	標準価格
CRE	0.5	10	9	65	8	11,600
CRE	0.75	10	8.5	65	8	11,600
CRE	1	10	8	65	8	10,200
CRE	1.25	12	9.5	65	10	11,600
CRE	1.5	12	9	65	10	10,200
CRE	1.75	12	8.5	65	10	11,600
CRE	2	12	8	65	10	10,200
CRE	2.25	14	9.5	70	12	11,600
CRE	2.5	14	9	70	12	10,200
CRE	2.75	16	10.5	75	12	11,600
CRE	3	16	10	75	12	10,200
CRE	3.25	18	11.5	75	16	13,200
CRE	3.5	18	11	75	16	11,600
CRE	3.75	20	12.5	75	16	13,200
CRE	4	20	12	75	16	11,600
CRE	4.25	21	12.5	75	16	15,000
CRE	4.5	21	12	75	16	12,900
CRE	4.75	22	12.5	80	16	15,000
CRE	5	22	12	80	16	12,900
CRE	5.25	23	12	80	16	16,500
CRE	5.5	23	12	80	16	14,400
CRE	5.75	26	14.5	80	20	16,500
CRE	6	26	14	80	20	14,400
CRE	6.25	26	13.5	80	20	19,300
CRE	6.5	26	13	80	20	16,600
CRE	6.75	26	12.5	83	20	19,300
CRE	7	26	12	83	20	16,600
CRE	7.25	27	12.5	85	20	21,900
CRE	7.5	27	12	85	20	19,300
CRE	7.75	28	12.5	88	20	21,900
CRE	8	28	12	88	20	19,300
CRE	8.5	30	13	90	20	21,700
CRE	9	32	14	95	25	23,500
CRE	9.5	33	14	95	25	25,200
CRE	10	35	15	95	25	25,200
CRE	10.5	35	14	100	25	30,400
CRE	11	35	13	100	25	30,400

型番	R	外径 (D)	先端径 (A)	全長 (L)	シャンク径 (d)	標準価格
CRE	11.5	38	15	100	25	33,700
CRE	12	38	14	100	25	33,700
CRE	12.5	40	15	105	32	42,900
CRE	13	40	14	105	32	42,900
CRE	13.5	45	18	110	32	51,400
CRE	14	45	17	110	32	51,400
CRE	14.5	45	16	110	32	60,000
CRE	15	45	15	110	32	60,000
CRE	15.5	50	19	110	32	78,500
CRE	16	50	18	110	32	78,500
CRE	16.5	52	19	115	32	96,000
CRE	17	52	18	115	32	83,600
CRE	17.5	52	17	115	32	99,000
CRE	18	52	16	115	32	86,700
CRE	18.5	55	18	115	32	108,200
CRE	19	55	17	115	32	94,400
CRE	19.5	57	18	115	32	113,600
CRE	20	57	17	115	32	99,000
CRE	20.5	67	26	125	32	129,100
CRE	21	67	25	125	32	112,800
CRE	21.5	67	24	125	32	129,100
CRE	22	67	23	125	32	112,800
CRE	22.5	67	22	125	32	133,100
CRE	23	67	21	125	32	116,400
CRE	23.5	67	20	125	32	137,000
CRE	24	67	19	125	32	119,700
CRE	24.5	67	18	125	32	141,100
CRE	25	67	17	125	32	123,000
CRE	25.5	70	19	135	32	156,500
CRE	26	70	18	135	32	136,600
CRE	26.5	70	17	135	32	164,500
CRE	27	70	16	135	32	143,400
CRE	27.5	75	20	145	32	188,000
CRE	28	75	19	145	32	164,100
CRE	28.5	75	18	145	32	211,400
CRE	29	75	17	145	32	184,500
CRE	29.5	75	16	145	32	211,400
CRE	30	75	15	145	32	184,500

(CM)  
センター面取りミル  
Center Chamfering End Mill (Standard)



材質=HSS-Co  
刃数=2枚  
リード角=右振り30°  
刃径公差=0~-0.03  
先端角公差=±15'

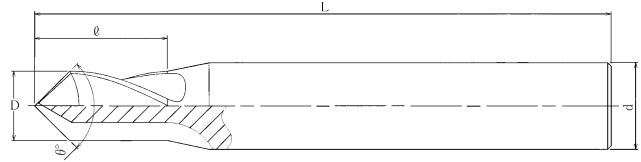
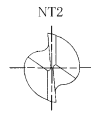

●注文例=型番、先端角、刃径、数量「CM 60°x4」

型番	先端角 (θ°)	刃径 (D)	刃長 (l)	全長 (L)	シャンク径 (d)	標準価格
CM	60°	4	11	75	8	9,000
		6	13	85	10	9,800
		8	19	100	12	11,400
		10	22	120	16	13,400
		12	26	125	16	20,000
		16	32	145	20	30,000
		20	38	165	25	34,500
		25	45	170	32	41,600
		30	45	175	32	72,400
		35	50	180	32	93,400
		40	60	200	42	137,500
CM	90°	4	11	75	8	7,900
		6	13	85	10	8,900
		8	19	100	12	10,300
		10	22	120	16	11,900
		12	26	125	16	18,000
		16	32	145	20	27,100

型番	先端角 (θ°)	刃径 (D)	刃長 (l)	全長 (L)	シャンク径 (d)	標準価格
CM	90°	20	38	165	25	31,400
		25	45	170	32	38,000
		30	45	175	32	65,700
		35	50	180	32	84,800
		40	60	200	42	124,900
CM	120°	4	11	75	8	9,000
		6	13	85	10	9,800
		8	19	100	12	11,400
		10	22	120	16	13,400
		12	26	125	16	20,000
		16	32	145	20	30,000
		20	38	165	25	34,500
		25	45	170	32	41,600
		30	45	175	32	72,400
		35	50	180	32	93,400
		40	60	200	42	137,500

(CMU)  
センター面取りミル「UF処理付(拡散浸透処理)」  
Center Chamfering End Mills (Ultra F. Stain Less Use)

材質=HSS-Co  
刃数=2枚  
リード角=右振り30°  
刃径公差=0~-0.03  
先端角公差=±15'

ウルトラF処理付

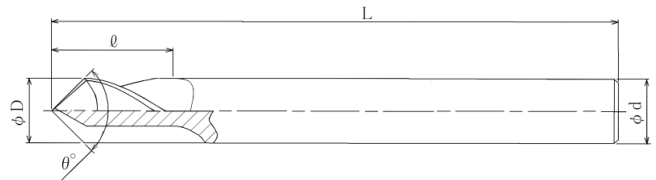

●注文例=型番、先端角、刃径、数量「CMU 60°x6」

型番	先端角 (θ°)	刃径 (D)	刃長 (l)	全長 (L)	シャンク径 (d)	標準価格
CMU	60°	6	12	80	8	12,400
		8	15	90	10	14,000
		10	18	100	12	16,600
		12	25	120	12	25,100
		16	30	140	16	37,700
		20	40	160	20	43,200
		25	50	170	25	52,100
		30	55	175	32	86,700
CMU	90°	6	12	80	8	12,400
		8	15	90	10	14,000
		10	18	100	12	16,600
		12	25	120	12	25,100

型番	先端角 (θ°)	刃径 (D)	刃長 (l)	全長 (L)	シャンク径 (d)	標準価格
CMU	90°	16	30	140	16	37,700
		20	40	160	20	43,200
		25	50	170	25	52,100
		30	55	175	32	86,700
CMU	120°	6	12	80	8	12,400
		8	15	90	10	14,000
		10	18	100	12	16,600
		12	25	120	12	25,100
		16	30	140	16	37,700
		20	40	160	20	43,200
		25	50	170	25	52,100
		30	55	175	32	86,700

(2TE)  
 テーパーエンドミル 2枚刃  
 2-Flute Tapered End Mills



材質=HSS-Co  
 刃数=2枚  
 リード角=右振れ25°  
 角度公差=±5'  
 先端径公差=0~-0.05

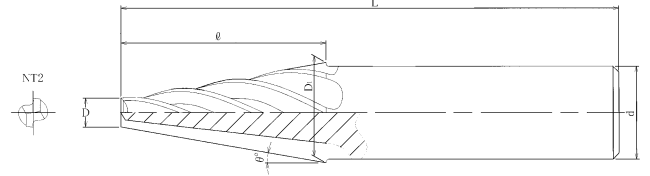

●注文例=型番、片角、先端径、数量 「2TE 30' x2」

型番	片角 (θ°)	先端径 (D)	大端径 (D1)	刃長 (ℓ)	全長 (L)	シャンク径 (d)	標準価格
2TE	30'	2	2.18	10	59	6	7,400
		3	3.26	15	61	6	7,400
		4	4.35	20	66	6	7,400
		5	5.44	25	71	6	7,400
		6	6.52	30	80	8	7,400
		8	8.7	40	90	10	7,800
		10	10.87	50	110	12	10,200
		12	13.04	60	120	12	14,000
		16	17.4	80	170	16	22,000
		20	21.75	100	200	20	33,600
25	26.75	100	200	25	58,100		
2TE	1°	2	2.35	10	59	6	7,400
		3	3.52	15	61	6	7,400
		4	4.69	20	66	6	7,400
		5	5.87	25	71	6	7,400
		6	7.04	30	80	8	7,400
		8	9.39	40	90	10	8,100
		10	11.74	50	110	12	11,500
		12	14.09	60	120	12	15,000
		16	18.79	80	170	16	24,200
		20	23.49	100	200	20	41,500
25	28.49	100	200	25	63,800		
2TE	1°30'	2	2.52	10	59	6	7,400
		3	3.79	15	61	6	7,400
		4	5.05	20	66	6	7,400
		5	6.31	25	71	6	7,400
		6	7.57	30	80	8	7,400
		8	10.09	40	90	10	9,000
		10	12.62	50	110	12	13,000
		12	15.14	60	120	16	17,300
		16	20.19	80	170	20	26,500
		20	25.24	100	200	25	54,100
25	30.24	100	200	32	74,200		
2TE	2°	2	2.7	10	59	6	7,700
		3	4.05	15	61	6	7,700
		4	5.4	20	66	6	7,700
		5	6.75	25	71	8	7,700
		6	8.09	30	80	8	7,700
		8	10.79	40	90	10	10,200
		10	13.49	50	110	12	14,600
		12	16.19	60	120	16	18,900
		16	21.59	80	170	20	29,100
		20	26.98	100	200	25	58,100
25	31.98	100	200	32	82,300		

型番	片角 (θ°)	先端径 (D)	大端径 (D1)	刃長 (ℓ)	全長 (L)	シャンク径 (d)	標準価格
2TE	2°30'	2	2.87	10	59	6	7,900
		3	4.31	15	61	6	7,900
		4	5.75	20	66	6	7,900
		5	7.18	25	71	8	7,900
		6	8.62	30	80	10	7,900
		8	11.49	40	90	12	10,700
		10	14.37	50	110	16	15,500
		12	17.24	60	120	16	20,400
		16	22.99	80	170	20	33,600
		20	28.73	100	200	25	63,800
25	33.73	100	200	32	89,100		
2TE	3°	2	3.05	10	59	6	7,900
		3	4.57	15	61	6	7,900
		4	6.1	20	66	6	7,900
		5	7.62	25	71	8	7,900
		6	9.14	30	80	10	7,900
		8	12.19	40	90	12	10,900
		10	15.24	50	110	16	16,100
		12	18.29	60	120	20	22,000
		16	24.38	80	170	25	37,400
		20	30.48	100	200	32	70,600
25	35.48	100	200	32	95,200		
2TE	4°	2	3.4	10	59	6	8,100
		3	5.09	15	61	6	8,100
		4	6.79	20	66	8	8,100
		5	8.49	25	71	8	8,100
		6	10.19	30	80	10	8,100
		8	13.59	40	90	12	14,600
		10	16.99	50	110	16	17,400
		12	20.39	60	120	20	25,900
		16	27.18	80	170	25	45,800
		20	33.98	100	200	32	82,300
25	38.98	100	200	32	102,100		
2TE	5°	2	3.75	10	59	6	8,900
		3	7.37	25	75	6	8,900
		4	9.24	30	80	8	8,900
		5	11.12	35	85	10	9,000
		6	12.99	40	90	12	12,100
		8	16.74	50	110	16	16,100
		10	20.49	60	130	20	20,400
		12	22.49	60	130	20	29,100
		16	29.99	80	170	25	54,100
		20	37.49	100	200	32	90,900
25	42.49	100	200	42	124,000		

# (2TE) テーパードエンドミル 2枚刃

2-Flute Tapered End Mills



材質=HSS-Co  
刃数=2枚  
リード角=右振れ25°  
角度公差=±5'  
先端径公差=0~-0.05

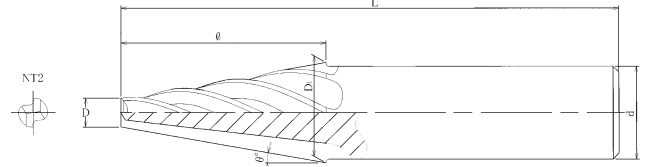

●注文例=型番、片角、先端径、数量 「2TE 6° x2」

型番	片角 (θ°)	先端径 (D)	大端径 (D1)	刃長 (ℓ)	全長 (L)	シャンク径 (d)	標準価格
2TE	6°	2	4.1	10	59	6	9,000
		3	8.26	25	75	8	9,000
		4	10.31	30	80	10	9,000
		5	12.36	35	85	12	10,700
		6	14.41	40	90	12	13,800
		8	18.51	50	110	16	18,500
		10	22.61	60	130	20	26,500
		12	24.61	60	130	20	41,700
		16	32.81	80	170	32	74,600
		20	41.02	100	200	32	117,900
		25	46.02	100	200	42	156,900
2TE	7°	2	4.46	10	59	6	9,800
		3	9.13	25	75	8	9,800
		4	11.36	30	80	10	9,800
		5	13.59	35	85	12	12,100
		6	15.82	40	90	12	15,100
		8	20.27	50	110	16	20,400
		10	24.73	60	130	20	32,100
		12	26.73	60	130	25	54,100
		16	35.65	80	170	32	95,200
		20	44.55	100	200	42	144,900
		25	49.55	100	200	42	189,500
2TE	8°	2	4.81	10	59	6	10,000
		3	10.03	25	75	10	10,000
		4	12.43	30	80	12	10,000
		5	14.84	35	85	12	13,200
		6	17.24	40	90	16	16,400
		8	22.05	50	110	20	23,000
		10	26.86	60	130	25	40,700
		12	28.86	60	130	25	68,200
		16	38.48	80	170	32	122,000
		20	48.11	100	200	42	186,000
		25	53.11	100	200	42	216,000
2TE	10°	2	5.53	10	59	6	10,400
		3	11.81	25	75	10	10,400
		4	14.58	30	80	12	10,400
		5	17.34	35	85	16	14,400
		6	20.1	40	90	16	18,200
		8	25.63	50	110	20	26,300
		10	31.16	60	130	25	48,600
		12	33.16	60	130	32	82,300
		16	44.21	80	170	32	143,900
		20	55.26	100	200	42	219,700
		25	60.26	100	200	42	238,400

型番	片角 (θ°)	先端径 (D)	大端径 (D1)	刃長 (ℓ)	全長 (L)	シャンク径 (d)	標準価格
2TE	15°	3	16.39	25	85	16	15,600
		4	20.07	30	90	16	22,500
		5	23.75	35	110	20	34,200
		6	27.43	40	120	25	45,200
		8	34.79	50	140	32	76,900
		10	42.15	60	150	32	129,400
		12	44.15	60	150	32	142,800
		16	58.87	80	170	42	239,200
		20	73.59	100	200	42	410,800
		2TE	20°	3	21.19	25	85
4	25.83			30	90	20	37,600
5	30.47			35	110	25	64,500
6	35.11			40	120	25	86,400
8	44.39			50	140	32	157,400
10	53.67			60	150	42	202,600
12	55.67			60	150	42	228,500
16	74.23			80	170	42	392,800
20	92.79	100	200	42	535,400		
2TE	25°	3	21.65	20	100	16	35,900
		4	27.32	25	105	25	56,100
		5	32.98	30	110	25	83,000
		6	38.64	35	120	32	121,600
		8	40.64	35	120	32	129,800
		10	47.31	40	140	32	139,200
		12	49.31	40	140	32	177,400
		16	62.63	50	150	42	321,400
20	75.96	60	160	42	414,100		
2TE	30°	4	27.09	20	100	25	50,900
		5	28.09	20	100	25	57,400
		6	34.87	25	110	32	95,100
		8	36.87	25	110	32	110,400
		10	44.64	30	130	32	146,200
		12	46.64	30	130	32	165,800
		16	73.73	50	150	42	292,700
		20	77.73	50	150	42	392,800

# (4TE) テーパードエンドミル 4枚刃

4-Flute Tapered End Mills

SINCE 1935  
**F.K.D.**®

材質=HSS-Co  
刃数=4枚  
リード角=右振り25°  
角度公差=±5'  
先端径公差=0~-0.05

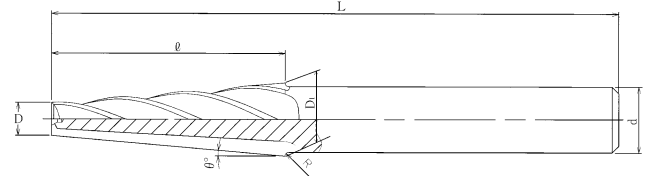

●注文例=型番、片角、先端径、数量「4TE 30' x3」 ◎(※)印は全てセンターカット仕上げとなります。

型番	片角 (θ°)	先端径 (D)	大端径 (D1)	刃長 (ℓ)	全長 (L)	シャンク径 (d)	標準価格
4TE	30'	※3	3.26	15	61	6	7,700
		4	4.35	20	66	6	7,700
		5	5.44	25	71	6	7,700
		6	6.52	30	80	8	7,700
		8	8.7	40	90	10	8,100
		10	10.87	50	110	12	10,700
		12	13.04	60	120	12	14,400
		16	17.4	80	170	16	22,900
		20	21.75	100	200	20	35,200
		25	26.75	100	200	25	60,600
4TE	1°	※3	3.52	15	61	6	7,700
		4	4.69	20	66	6	7,700
		5	5.87	25	71	6	7,700
		6	7.04	30	80	8	7,700
		8	9.39	40	90	10	8,700
		10	11.74	50	110	12	12,100
		12	14.09	60	120	12	15,500
		16	18.79	80	170	16	25,200
		20	23.49	100	200	20	43,400
		25	28.49	100	200	25	66,700
4TE	1°30'	※3	3.79	15	61	6	7,700
		4	5.05	20	66	6	7,700
		5	6.31	25	71	6	7,700
		6	7.57	30	80	8	7,700
		8	10.09	40	90	10	9,300
		10	12.62	50	110	12	13,300
		12	15.14	60	120	16	18,200
		16	20.19	80	170	20	27,600
		20	25.24	100	200	25	56,400
		25	30.24	100	200	32	77,400
4TE	2°	※3	4.05	15	61	6	7,900
		4	5.4	20	66	6	7,900
		5	6.75	25	71	8	7,900
		6	8.09	30	80	8	7,900
		8	10.79	40	90	10	10,700
		10	13.49	50	110	12	15,100
		12	16.19	60	120	16	20,000
		16	21.59	80	170	20	30,200
		20	26.98	100	200	25	60,600
		25	31.98	100	200	32	86,100

型番	片角 (θ°)	先端径 (D)	大端径 (D1)	刃長 (ℓ)	全長 (L)	シャンク径 (d)	標準価格
4TE	2°30'	※3	4.31	15	61	6	8,200
		4	5.75	20	66	6	8,200
		5	7.18	25	71	8	8,200
		6	8.62	30	80	10	8,200
		8	11.49	40	90	12	11,200
		10	14.37	50	110	16	16,100
		12	17.24	60	120	16	21,300
		16	22.99	80	170	20	35,200
		20	28.73	100	200	25	66,700
		25	33.73	100	200	32	92,800
4TE	3°	※3	4.57	15	61	6	8,200
		4	6.1	20	66	6	8,200
		5	7.62	25	71	8	8,200
		6	9.14	30	80	10	8,200
		8	12.19	40	90	12	11,400
		10	15.24	50	110	16	16,900
		12	18.29	60	120	20	22,900
		16	24.38	80	170	25	39,300
		20	30.48	100	200	32	73,700
		25	35.48	100	200	32	99,200
4TE	4°	※3	5.09	15	61	6	8,300
		4	6.79	20	66	8	8,300
		5	8.49	25	71	8	8,300
		6	10.19	30	80	10	8,300
		8	13.59	40	90	12	15,100
		10	16.99	50	110	16	18,300
		12	20.39	60	120	20	26,700
		16	27.18	80	170	25	47,600
		20	33.98	100	200	32	86,100
		25	38.98	100	200	32	106,400
4TE	5°	※3	7.37	25	75	6	9,100
		4	9.24	30	80	8	9,100
		5	11.12	35	85	10	9,300
		6	12.99	40	90	12	12,400
		8	16.74	50	110	16	16,900
		10	20.49	60	130	20	21,300
		12	22.49	60	130	20	30,200
		16	29.99	80	170	25	56,400
		20	37.49	100	200	32	94,500
		25	42.49	100	200	42	129,400

# (4TE) テーパーエンドミル 4枚刃

4-Flute Tapered End Mills



材質=HSS-Co  
刃数=4枚  
リード角=右振り25°  
角度公差=±5'  
先端径公差=0~-0.05

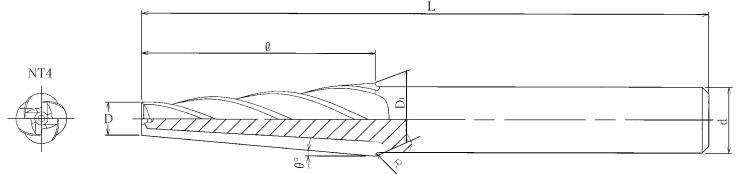

●注文例=型番、片角、先端径、数量「4TE 6° x3」 ◎(※)印は全てセンターカット仕上げとなります。

型番	片角 (θ°)	先端径 (D)	大端径 (D1)	刃長 (ℓ)	全長 (L)	シャンク径 (d)	標準価格
4TE	6°	※3	8.26	25	75	8	9,300
		4	10.31	30	80	10	9,300
		5	12.36	35	85	12	11,200
		6	14.41	40	90	12	14,400
		8	18.51	50	110	16	19,400
		10	22.61	60	130	20	27,600
		12	24.61	60	130	20	43,500
		16	32.81	80	170	32	77,900
		20	41.02	100	200	32	122,700
		25	46.02	100	200	42	163,400
4TE	7°	※3	9.13	25	75	8	10,200
		4	11.36	30	80	10	10,200
		5	13.59	35	85	12	12,400
		6	15.82	40	90	12	15,600
		8	20.27	50	110	16	21,300
		10	24.73	60	130	20	33,600
		12	26.73	60	130	25	56,400
		16	35.65	80	170	32	99,200
		20	44.55	100	200	42	150,900
		25	49.55	100	200	42	197,500
4TE	8°	※3	10.03	25	75	10	10,400
		4	12.43	30	80	12	10,400
		5	14.84	35	85	12	14,000
		6	17.24	40	90	16	17,300
		8	22.05	50	110	20	24,200
		10	26.86	60	130	25	42,300
		12	28.86	60	130	25	71,200
		16	38.48	80	170	32	127,300
		20	48.11	100	200	42	193,900
		25	53.11	100	200	42	225,100
4TE	10°	※3	11.81	25	75	10	10,800
		4	14.58	30	80	12	10,800
		5	17.34	35	85	16	15,000
		6	20.1	40	90	16	19,100
		8	25.63	50	110	20	27,500
		10	31.16	60	130	25	50,600
		12	33.16	60	130	32	86,100
		16	44.21	80	170	32	149,800
		20	55.26	100	200	42	229,000
		25	60.26	100	200	42	248,500

型番	片角 (θ°)	先端径 (D)	大端径 (D1)	刃長 (ℓ)	全長 (L)	シャンク径 (d)	標準価格
4TE	15°	※3	16.39	25	85	16	16,400
		※4	20.07	30	90	16	23,700
		5	23.75	35	110	20	35,300
		6	27.43	40	120	25	47,300
		8	34.79	50	140	32	80,200
		10	42.15	60	150	32	134,800
		12	44.15	60	150	32	148,900
		16	58.87	80	170	42	249,300
		20	73.59	100	200	42	427,900
		4TE	20°	※3	21.19	25	85
※4	25.83			30	90	20	39,400
※5	30.47			35	110	25	67,200
6	35.11			40	120	25	90,200
8	44.39			50	140	32	164,100
10	53.67			60	150	42	211,000
12	55.67			60	150	42	238,100
16	74.23			80	170	42	409,300
20	92.79			100	200	42	557,900
4TE	25°			※3	21.65	20	100
		※4	27.32	25	105	25	62,400
		※5	32.98	30	110	25	92,200
		6	38.64	35	120	32	135,000
		8	40.64	35	120	32	144,300
		10	47.31	40	140	32	154,800
		12	49.31	40	140	32	197,300
		16	62.63	50	150	42	334,700
		20	75.96	60	160	42	431,300
		4TE	30°	※4	27.09	20	100
※5	28.09			20	100	25	63,700
6	34.87			25	110	32	105,600
8	36.87			25	110	32	122,700
10	44.64			30	130	32	162,400
12	46.64			30	130	32	184,200
16	73.73			50	150	42	305,100
20	77.73	50	150	42	409,300		

(2TES)  
 テーパーエンドミル 2枚刃 (ショート刃)  
 2-Flute Tapered End Mills (Short Flute)

SINCE 1935  
 F.K.D.®

材質=HSS-Co  
 刃数=2枚  
 リード角=右振れ25°  
 角度公差=±5'  
 先端径公差=0~-0.05

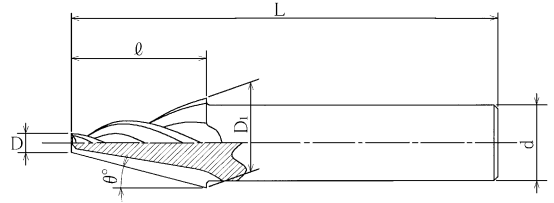

●注文例=型番、片角、先端径、数量「2TE-S 15°x10」

型番	片角 (θ°)	先端径 (D)	大端径 (D1)	刃長 (l)	全長 (L)	シャンク径 (d)	標準価格
2TES	15°	10	36.79	50	140	32	96,300
		12	38.79	50	140	32	125,700
		16	42.79	50	140	32	145,400
		20	46.79	50	140	32	176,600

型番	片角 (θ°)	先端径 (D)	大端径 (D1)	刃長 (l)	全長 (L)	シャンク径 (d)	標準価格
2TES	20°	10	46.4	50	140	32	192,100
		12	48.4	50	140	32	227,700
		16	52.4	50	140	32	235,500
		20	56.4	50	140	32	259,200

(4TES)  
 テーパーエンドミル 4枚刃 (ショート刃)  
 4-Flute Tapered End Mills (Short Flute)

材質=HSS-Co  
 刃数=4枚  
 リード角=右振れ25°  
 角度公差=±5'  
 先端径公差=0~-0.05  
 (センター穴付)

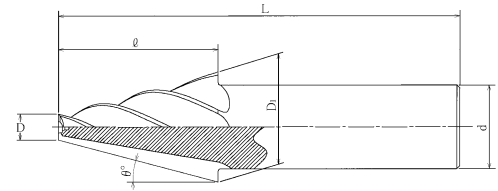
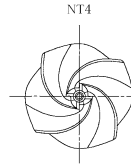

●注文例=型番、片角、先端径、数量「4TE-S 15°x10」

型番	片角 (θ°)	先端径 (D)	大端径 (D1)	刃長 (l)	全長 (L)	シャンク径 (d)	標準価格
4TES	15°	10	36.79	50	140	32	100,300
		12	38.79	50	140	32	131,100
		16	42.79	50	140	32	151,700
		20	46.79	50	140	32	184,200

型番	片角 (θ°)	先端径 (D)	大端径 (D1)	刃長 (l)	全長 (L)	シャンク径 (d)	標準価格
4TES	20°	10	46.4	50	140	32	200,100
		12	48.4	50	140	32	237,500
		16	52.4	50	140	32	245,600
		20	56.4	50	140	32	269,900

(RB2TE) 2-Flute Tapered Radius Ball End Mills  
 テーパーラジアスエンドミル 2枚刃



材質=HSS-Co  
 刃数=2枚  
 リード角=右振れ25°  
 角度公差=±5°  
 R公差=±0.025

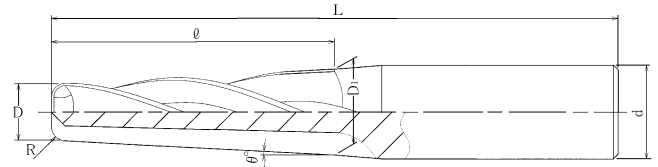

●注用例=型番、先端径、片角、コーナーR、数量「RB2TE 3x1°x0.5R」

型番	先端径	片角 (θ°)	コーナー (R)	大端径 (D1)	刃長 (ℓ)	全長 (L)	シャンク径 (d)	標準価格
RB2TE	3	1°	0.5	3.524	15	61	6	12,200
			1	3.524	15	61	6	12,200
		1°30'	0.5	3.786	15	61	6	12,200
			1	3.786	15	61	6	12,200
		2°	0.5	4.048	15	61	6	12,400
			1	4.048	15	61	6	12,400
3°	0.5	4.572	15	61	6	13,100		
	1	4.572	15	61	6	13,100		
RB2TE	4	1°	0.5	4.698	20	66	6	12,200
			1	4.698	20	66	6	12,200
		1°30'	0.5	5.048	20	66	6	12,200
			1	5.048	20	66	6	12,200
		2°	0.5	5.397	20	66	6	12,400
			1	5.397	20	66	6	12,400
3°	0.5	6.096	20	66	6	13,100		
	1	6.096	20	66	6	13,100		
RB2TE	5	1°	0.5	5.873	25	71	6	12,200
			1	5.873	25	71	6	12,200
			1.5	5.873	25	71	6	12,200
		1°30'	0.5	6.31	25	71	6	12,200
			1	6.31	25	71	6	12,200
			1.5	6.31	25	71	6	12,200
		2°	0.5	6.746	25	71	8	12,400
			1	6.746	25	71	8	12,400
			1.5	6.746	25	71	8	12,400
		3°	0.5	7.621	25	71	8	13,100
			1	7.621	25	71	8	13,100
			1.5	7.621	25	71	8	13,100
RB2TE	6	1°	0.5	7.048	30	80	8	12,200
			1	7.048	30	80	8	12,200
			1.5	7.048	30	80	8	12,200
			2	7.048	30	80	8	12,200
		1°30'	0.5	7.571	30	80	8	12,200
			1	7.571	30	80	8	12,200
			1.5	7.571	30	80	8	12,200
			2	7.571	30	80	8	12,200
		2°	0.5	8.095	30	80	8	12,400
			1	8.095	30	80	8	12,400
			1.5	8.095	30	80	8	12,400
			2	8.095	30	80	8	12,400
3°	0.5	9.145	30	80	10	13,100		
	1	9.145	30	80	10	13,100		
	1.5	9.145	30	80	10	13,100		
	2	9.145	30	80	10	13,100		
RB2TE	8	1°	0.5	9.397	40	90	10	15,100
			1	9.397	40	90	10	15,100
			1.5	9.397	40	90	10	15,100
			2	9.397	40	90	10	15,100
		1°30'	0.5	10.095	40	90	10	15,100
			1	10.095	40	90	10	15,100
			1.5	10.095	40	90	10	15,100
			2	10.095	40	90	10	15,100
		2°	0.5	10.794	40	90	10	17,300
			1	10.794	40	90	10	17,300
			1.5	10.794	40	90	10	17,300
			2	10.794	40	90	10	17,300
3°	0.5	12.193	40	90	12	18,300		
	1	12.193	40	90	12	18,300		
	1.5	12.193	40	90	12	18,300		
	2	12.193	40	90	12	18,300		
RB2TE	10	1°	0.5	11.746	50	110	12	19,400
			1	11.746	50	110	12	19,400
			1.5	11.746	50	110	12	19,400
			2	11.746	50	110	12	19,400
			2.5	11.746	50	110	12	19,400
			3	11.746	50	110	12	19,400
		1°30'	0.5	12.619	50	110	12	19,400
			1	12.619	50	110	12	19,400
			1.5	12.619	50	110	12	19,400
			2	12.619	50	110	12	19,400
			2.5	12.619	50	110	12	19,400
			3	12.619	50	110	12	19,400
RB2TE	12	2°	0.5	13.492	50	110	12	22,300
			1	13.492	50	110	12	22,300
			1.5	13.492	50	110	12	22,300
			2	13.492	50	110	12	22,300
			2.5	13.492	50	110	12	22,300
			3	13.492	50	110	12	22,300
		3°	0.5	15.241	50	110	16	24,200
			1	15.241	50	110	16	24,200
			1.5	15.241	50	110	16	24,200
			2	15.241	50	110	16	24,200
			2.5	15.241	50	110	16	24,200
			3	15.241	50	110	16	24,200
RB2TE	16	1°	1	14.095	60	120	12	24,700
			1.5	14.095	60	120	12	24,700
			2	14.095	60	120	12	24,700
			3	14.095	60	120	12	24,700
		1°30'	1	15.143	60	120	16	24,700
			1.5	15.143	60	120	16	24,700
			2	15.143	60	120	16	24,700
			3	15.143	60	120	16	24,700
		2°	1	16.19	60	120	16	29,100
			1.5	16.19	60	120	16	29,100
			2	16.19	60	120	16	29,100
			3	16.19	60	120	16	29,100
3°	1	18.289	60	120	20	32,100		
	1.5	18.289	60	120	20	32,100		
	2	18.289	60	120	20	32,100		
	3	18.289	60	120	20	32,100		
RB2TE	16	1°	1	18.794	80	170	16	34,400
			1.5	18.794	80	170	16	34,400
			2	18.794	80	170	16	34,400
			3	18.794	80	170	16	34,400
		1°30'	1	20.19	80	170	20	34,400
			1.5	20.19	80	170	20	34,400
			2	20.19	80	170	20	34,400
			3	20.19	80	170	20	34,400
		2°	1	21.587	80	170	20	39,700
			1.5	21.587	80	170	20	39,700
			2	21.587	80	170	20	39,700
			3	21.587	80	170	20	39,700
3°	1	24.386	80	170	25	48,400		
	1.5	24.386	80	170	25	48,400		
	2	24.386	80	170	25	48,400		
	3	24.386	80	170	25	48,400		



# (KE-OH) キー溝用エンドミル(プラス公差)

Key Way End Mills, Straight Shank (Over High Tolerance)

SINCE 1935  
F.K.D.®

材質=HSS-Co  
刃数=2枚  
リード角=右振り12°  
刃径公差=0~+0.02

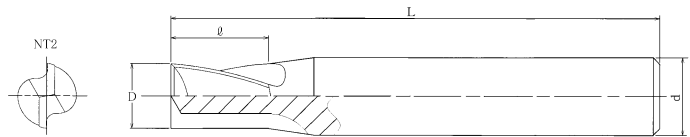

●注文例=型番、刃径、数量「KE-OH 3」

型番	刃径 (D)	刃長 (ℓ)	全長 (L)	シャンク径 (d)	標準価格
KE-OH	3	5	50	6	4,500
KE-OH	4	6	60	8	4,500
KE-OH	5	8	60	8	4,500
KE-OH	6	8	60	8	4,500
KE-OH	7	10	65	10	5,000
KE-OH	8	10	65	10	5,000
KE-OH	9	12	65	12	5,800
KE-OH	10	15	75	12	5,800
KE-OH	11	18	75	12	6,500
KE-OH	12	18	75	12	6,500
KE-OH	13	20	75	12	7,000
KE-OH	14	20	75	12	7,700
KE-OH	15	22	75	16	8,700
KE-OH	16	22	80	16	9,100

型番	刃径 (D)	刃長 (ℓ)	全長 (L)	シャンク径 (d)	標準価格
KE-OH	17	22	80	16	10,000
KE-OH	18	22	80	20	11,800
KE-OH	19	22	85	20	11,800
KE-OH	20	22	85	20	14,600
KE-OH	21	25	90	20	14,600
KE-OH	22	25	90	20	17,600
KE-OH	23	25	95	25	19,300
KE-OH	24	25	95	25	19,300
KE-OH	25	25	95	25	20,500
KE-OH	26	25	95	25	23,100
KE-OH	27	25	95	25	25,300
KE-OH	28	30	100	25	25,300
KE-OH	29	30	100	25	29,800
KE-OH	30	30	100	25	32,800

特定代理店在庫

# (KE-OH-BS5) キー溝用エンドミル・BSシャンク(プラス公差)

Key Way End Mills, BS5 Shank (Over High Tolerance)

●注文例=型番、刃径、数量「KE-OH-BS5 3」

型番	刃径 (D)	刃長 (ℓ)	全長 (L)	シャンク	標準価格
KE-OH-BS5	3	4.5	62	BS5	4,300
	4	6	64	BS5	4,300
	5	7.5	65	BS5	4,300
	6	9	65	BS5	4,300
	7	10.5	68	BS5	4,600
	8	12	70	BS5	4,600
	10	15	73	BS5	4,600
	12	18	76	BS5	4,600

材質=HSS-Co  
刃数=2枚

リード角=右振り12°  
刃径公差=0~+0.02

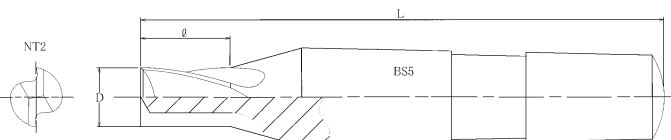

# (KE-OL) キー溝用エンドミル(マイナス公差)

SINCE 1935  
F.K.D.®

Key Way End Mills, Straight Shank (Over Low Tolerance)

材質=HSS-Co  
刃数=2枚  
リード角=右振り12°  
刃径公差=0~-0.02

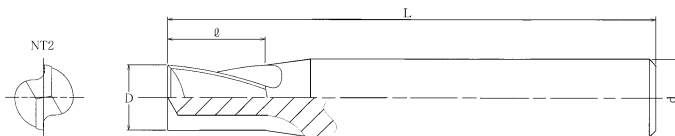

●注文例=型番、刃径、数量「KE-OL 3」

型番	刃径 (D)	刃長 (Ø)	全長 (L)	シャンク径 (d)	標準価格
KE-OL	3	5	50	6	4,500
KE-OL	4	6	60	8	4,500
KE-OL	5	8	60	8	4,500
KE-OL	6	8	60	8	4,500
KE-OL	7	10	65	10	5,000
KE-OL	8	10	65	10	5,000
KE-OL	9	12	65	12	5,800
KE-OL	10	15	75	12	5,800
KE-OL	11	18	75	12	6,500
KE-OL	12	18	75	12	6,500
KE-OL	13	20	75	12	7,000
KE-OL	14	20	75	12	7,700
KE-OL	15	22	75	16	8,700
KE-OL	16	22	80	16	9,100

型番	刃径 (D)	刃長 (Ø)	全長 (L)	シャンク径 (d)	標準価格
KE-OL	17	22	80	16	10,000
KE-OL	18	22	80	20	11,800
KE-OL	19	22	85	20	11,800
KE-OL	20	22	85	20	14,600
KE-OL	21	25	90	20	14,600
KE-OL	22	25	90	20	17,600
KE-OL	23	25	95	25	19,300
KE-OL	24	25	95	25	19,300
KE-OL	25	25	95	25	20,500
KE-OL	26	25	95	25	23,100
KE-OL	27	25	95	25	25,300
KE-OL	28	30	100	25	25,300
KE-OL	29	30	100	25	29,800
KE-OL	30	30	100	25	32,800

特定代理店在庫

# (KE-OL-BS5) キー溝用エンドミル・BSシャンク(マイナス公差)

Key Way End Mills, BS5 Shank (Over Low Tolerance)

●注文例=型番、刃径、数量「KE-OL-BS5 3」

型番	刃径 (D)	刃長 (Ø)	全長 (L)	シャンク	標準価格
KE-OL-BS5	3	4.5	62	BS5	4,300
	4	6	64	BS5	4,300
	5	7.5	65	BS5	4,300
	6	9	65	BS5	4,300
	7	10.5	68	BS5	4,600
	8	12	70	BS5	4,600
	10	15	73	BS5	4,600
	12	18	76	BS5	4,600

材質=HSS-Co  
刃数=2枚

リード角=右振り12°  
刃径公差=0~-0.02

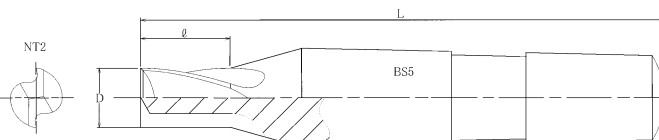

特定代理店在庫

# (2S-T / 4S-T) 引きネジ付3Sエンドミル

SINCE 1935  
F.K.D.®

2-Flute End Mills, Drawing Thread Taper Shank

4-Flute End Mills, Drawing Thread Taper Shank

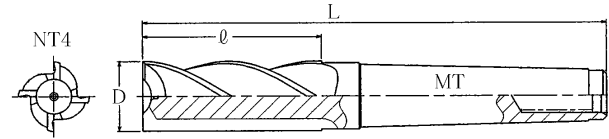
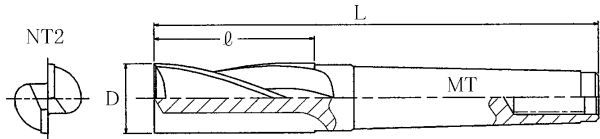

材質=HSS-Co リード角=右振り30° (2S-T)  
刃数=2枚 刃径公差=0~-0.03

材質=HSS-Co リード角=右振り30° (4S-T)  
刃数=4枚 刃径公差=0~+0.03

●注文例=型番、刃径、シャンク、数量「2S-T 12xBS7」

●注文例=型番、刃径、シャンク、数量「4S-T 12xBS7」

型番	刃径 (D)	刃長 (l)	全長 (L)	シャンク	標準価格
2S-T	12	35	125	BS7	15,400
2S-T	14	35	125	BS7	15,400
2S-T	15	40	130	BS7	15,400
2S-T	16	40	130	BS7	17,300
2S-T	18	40	130	BS7	18,400
2S-T	20	45	135	BS7	20,200
2S-T	22	45	135	BS7	24,000
2S-T	24	50	140	BS7	25,800
2S-T	25	50	140	BS7	29,000
2S-T	26	50	140	BS7	30,200
2S-T	28	55	175	BS9	38,100
2S-T	30	55	175	BS9	41,200
2S-T	32	60	180	BS9	49,300
2S-T	34	60	180	BS9	55,200
2S-T	35	60	180	BS9	58,500
2S-T	36	60	180	BS9	65,100
2S-T	38	65	185	BS9	74,100
2S-T	40	65	185	BS9	81,100
2S-T	45	70	190	BS9	112,900
2S-T	50	70	190	BS9	143,900
2S-T	60	75	195	BS9	195,200

型番	刃径 (D)	刃長 (l)	全長 (L)	シャンク	標準価格
4S-T	12	40	130	BS7	16,200
4S-T	14	40	130	BS7	16,200
4S-T	15	45	135	BS7	16,200
4S-T	16	45	135	BS7	18,200
4S-T	18	45	135	BS7	19,700
4S-T	20	50	140	BS7	21,600
4S-T	22	50	140	BS7	25,300
4S-T	24	55	145	BS7	27,300
4S-T	25	55	145	BS7	30,400
4S-T	26	55	145	BS7	31,900
4S-T	28	60	180	BS9	40,600
4S-T	30	60	180	BS9	43,700
4S-T	32	65	185	BS9	52,600
4S-T	34	65	185	BS9	58,500
4S-T	35	65	185	BS9	62,100
4S-T	36	65	185	BS9	68,900
4S-T	38	70	190	BS9	78,500
4S-T	40	70	190	BS9	86,100
4S-T	45	75	195	BS9	119,700
4S-T	50	75	195	BS9	152,800
4S-T	60	80	200	BS9	206,800

●注文例=型番、刃径、シャンク、数量「2S-T 12xMT2」

●注文例=型番、刃径、シャンク、数量「4S-T 12xMT2」

型番	刃径 (D)	刃長 (l)	全長 (L)	シャンク	標準価格
2S-T	12	35	115	MT2	14,700
2S-T	14	35	115	MT2	14,700
2S-T	15	40	120	MT2	14,700
2S-T	16	40	120	MT2	16,700
2S-T	18	40	120	MT2	17,400
2S-T	20	45	125	MT2	19,300
2S-T	22	45	125	MT2	22,900
2S-T	24	50	150	MT3	24,600
2S-T	25	50	150	MT3	27,700
2S-T	26	50	150	MT3	28,800
2S-T	28	55	155	MT3	36,200
2S-T	30	55	155	MT3	39,300
2S-T	32	60	160	MT3	47,000
2S-T	34	60	160	MT3	52,700
2S-T	35	60	185	MT4	55,800
2S-T	36	60	185	MT4	61,900
2S-T	38	65	190	MT4	70,400
2S-T	40	65	190	MT4	77,300
2S-T	45	70	195	MT4	106,400
2S-T	50	70	195	MT4	137,200
2S-T	60	75	200	MT5	185,700

型番	刃径 (D)	刃長 (l)	全長 (L)	シャンク	標準価格
4S-T	12	40	120	MT2	15,600
4S-T	14	40	120	MT2	15,600
4S-T	15	45	125	MT2	15,600
4S-T	16	45	125	MT2	17,300
4S-T	18	45	125	MT2	18,600
4S-T	20	50	130	MT2	20,400
4S-T	22	50	130	MT2	24,200
4S-T	24	55	155	MT3	26,000
4S-T	25	55	155	MT3	29,100
4S-T	26	55	155	MT3	30,400
4S-T	28	60	160	MT3	38,400
4S-T	30	60	160	MT3	41,700
4S-T	32	65	165	MT3	50,100
4S-T	34	65	165	MT3	55,900
4S-T	35	65	190	MT4	58,900
4S-T	36	65	190	MT4	65,700
4S-T	38	70	195	MT4	74,800
4S-T	40	70	195	MT4	81,900
4S-T	45	75	200	MT4	114,100
4S-T	50	75	200	MT4	145,400
4S-T	60	80	205	MT5	196,900

特定代理店在庫

## (2SL-T) 引きネジ付ロングハイヘリエンドミル 2枚刃

2-Flute Hi-Helical Long Flute End Mills, Drawing Thread Taper Shank

SINCE 1935  
F.K.D.®

●注文例=型番、刃径、シャンク、数量「2SL-T 30xMT4」

型番	刃径 (D)	刃長 (ℓ)	全長 (L)	シャンク	標準価格
2SL-T	30	100	225	MT4	64,100
2SL-T	35	100	225	MT4	93,200
2SL-T	40	100	225	MT4	119,700
2SL-T	45	150	310	MT5	226,100
2SL-T	50	150	310	MT5	226,100
2SL-T	50	200	360	MT5	298,500
2SL-T	60	200	360	MT5	412,600
2SL-T	60	200	410	BS12	433,400

材質=HSS-Co  
刃数=2枚

リード角=右振り45°  
刃径公差=0~-0.03

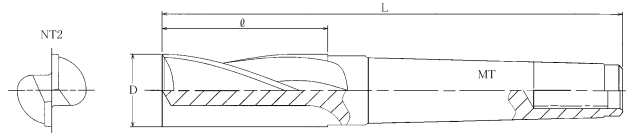

特定代理店在庫

## (4SL-T) 引きネジ付ロングハイヘリエンドミル 4枚刃

4-Flute Hi-Helical Long Flute End Mills, Drawing Thread Taper Shank

●注文例=型番、刃径、シャンク、数量「4SL-T 30xMT4」

型番	刃径 (D)	刃長 (ℓ)	全長 (L)	シャンク	標準価格
4SL-T	30	100	225	MT4	64,100
4SL-T	35	100	225	MT4	93,200
4SL-T	40	100	225	MT4	119,700
4SL-T	40	150	310	MT5	158,600
4SL-T	50	150	310	MT5	226,100
4SL-T	50	200	360	MT5	298,500
4SL-T	60	150	310	MT5	412,600
4SL-T	60	200	360	MT5	412,600
4SL-T	50	150	360	BS12	237,600
4SL-T	60	200	410	BS12	313,600

材質=HSS-Co  
刃数=4枚

リード角=右振り45°  
刃径公差=0~+0.03

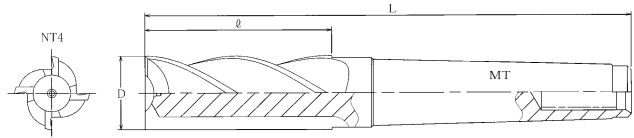

(センター穴付)

(SL-ST)  
スロットングエンドミル 2枚刃  
2-Flute Slotting End Mills, Straight Shank

SINCE 1935  
F.K.D.®

材質=HSS-Co  
刃数=2枚  
刃径公差=0~-0.05

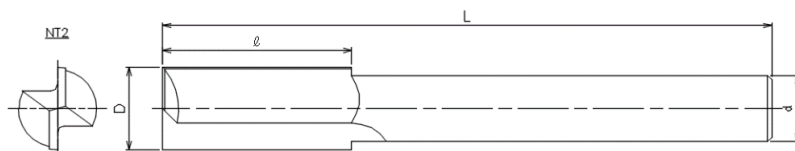

ストレートシャンク

●注文例=型番、刃径、シャンク、数量 「SL-ST 3xストレートシャンク」

型番	刃径 (D)	刃長 (ℓ)	全長 (L)	シャンク	標準価格
SL-ST	3	12	70	6	5,400
SL-ST	4	15	70	6	5,400
SL-ST	5	15	70	6	5,400
SL-ST	6	20	75	6	5,600
SL-ST	7	20	75	8	5,700
SL-ST	8	20	75	8	5,700
SL-ST	9	25	80	10	6,500
SL-ST	10	25	80	10	6,500
SL-ST	11	25	80	10	6,900
SL-ST	12	25	80	12	7,000
SL-ST	13	25	80	12	8,600
SL-ST	14	30	130	12	8,100
SL-ST	15	35	135	12	9,400
SL-ST	16	35	135	16	11,000

型番	刃径 (D)	刃長 (ℓ)	全長 (L)	シャンク	標準価格
SL-ST	17	40	140	16	14,600
SL-ST	18	40	140	16	14,600
SL-ST	19	45	145	16	14,600
SL-ST	20	45	145	16	14,600
SL-ST	21	50	150	20	17,700
SL-ST	22	50	150	20	17,700
SL-ST	23	50	150	20	18,500
SL-ST	24	50	150	20	20,500
SL-ST	25	50	150	20	20,500
SL-ST	26	50	150	25	23,700
SL-ST	27	55	155	25	28,800
SL-ST	28	55	155	25	28,800
SL-ST	29	55	155	25	33,200
SL-ST	30	55	155	25	33,200

特定代理店在庫

(SL-BS)  
スロットングエンドミル 2枚刃  
2-Flute Slotting End Mills, BS Shank

SINCE 1935  
F.K.D.®

材質=HSS  
刃数=2枚  
刃径公差=0~-0.05

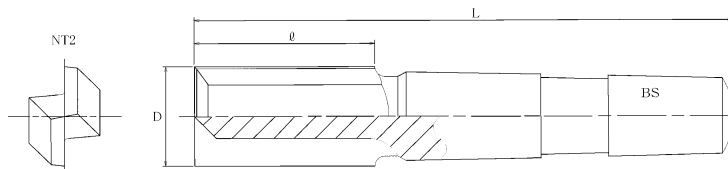

BS5シャンク

●注文例=型番、刃径、シャンク、数量「SL-BS 3x30xBS5」

型番	刃径 (D)	刃長 (l)	全長 (L)	シャンク	標準価格
SL-BS	3	12	67	BS5	3,800
SL-BS	3.5	14	69	BS5	3,800
SL-BS	4	14	69	BS5	3,800
SL-BS	4.5	16	71	BS5	3,800
SL-BS	5	16	71	BS5	3,800
SL-BS	5.5	18	73	BS5	3,800
SL-BS	6	18	73	BS5	3,800
SL-BS	6.5	18	73	BS5	3,800
SL-BS	7	18	73	BS5	3,800
SL-BS	7.5	18	73	BS5	3,800
SL-BS	8	18	73	BS5	3,800
SL-BS	8.5	20	75	BS5	3,800
SL-BS	9	20	75	BS5	3,800
SL-BS	9.5	20	75	BS5	4,300
SL-BS	10	20	75	BS5	4,300
SL-BS	10.5	22	76	BS5	5,300
SL-BS	11	22	76	BS5	5,300

型番	刃径 (D)	刃長 (l)	全長 (L)	シャンク	標準価格
SL-BS	11.5	24	77	BS5	5,300
SL-BS	12	24	77	BS5	5,300
SL-BS	12.5	24	77	BS5	6,100
SL-BS	13	24	77	BS5	6,100
SL-BS	13.5	24	77	BS5	6,600
SL-BS	14	24	77	BS5	6,600
SL-BS	14.5	24	77	BS5	6,600
SL-BS	15	24	77	BS5	6,600
SL-BS	1/8"	12	67	BS5	3,800
SL-BS	3/16"	16	71	BS5	3,800
SL-BS	1/4"	18	73	BS5	3,800
SL-BS	5/16"	18	73	BS5	3,800
SL-BS	3/8"	20	75	BS5	4,300
SL-BS	7/16"	22	76	BS5	5,300
SL-BS	1/2"	24	77	BS5	6,100
SL-BS	9/16"	24	77	BS5	6,600

特定代理店在庫

(SL-MT)  
スロットングエンドミル 2枚刃  
2-Flute Slotting End Mills, MT Shank

材質=HSS  
刃数=2枚  
刃径公差=0~-0.05

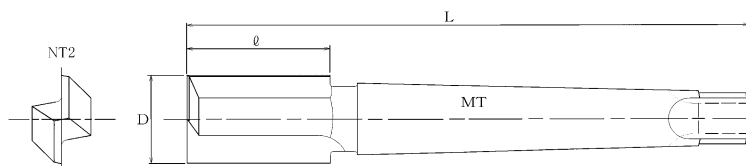

MT1シャンク

●注文例=型番、刃径、シャンク、数量「SL-MT 3xMT1」

型番	刃径 (D)	刃長 (l)	全長 (L)	シャンク	標準価格
SL-MT	3	12	84	MT1	5,300
SL-MT	4	14	86	MT1	5,300
SL-MT	5	16	88	MT1	5,300
SL-MT	6	18	90	MT1	5,300
SL-MT	7	18	90	MT1	5,800
SL-MT	8	18	90	MT1	5,800
SL-MT	9	20	92	MT1	5,900

型番	刃径 (D)	刃長 (l)	全長 (L)	シャンク	標準価格
SL-MT	10	20	92	MT1	5,900
SL-MT	11	22	93	MT1	6,900
SL-MT	12	24	94	MT1	6,900
SL-MT	13	24	94	MT1	7,400
SL-MT	14	24	94	MT1	8,100
SL-MT	15	24	94	MT1	8,100

特定代理店在庫

# (SL-BS-L) ロングスロットングエンドミル 2枚刃

SINCE 1935  
F.K.D.®

2-Flute Long Flute Slotting End Mills, BS Shank

材質=HSS  
刃数=2枚  
刃径公差=0~-0.05

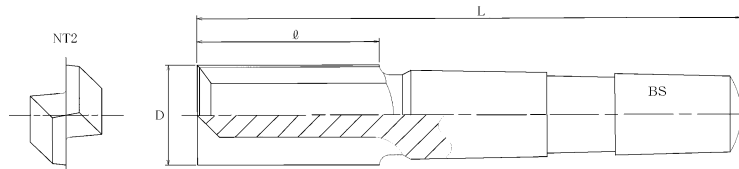

(ロング刃)

BS5シャンク

●注文例=型番、刃径、シャンク、数量「SL-BS-L 3x30xBS5」

型番	刃径 (D)	刃長 (ℓ)	全長 (L)	シャンク	標準価格
SL-BS-L	3	30	85	BS5	5,600
SL-BS-L	4	30	85	BS5	5,600
SL-BS-L	4	40	95	BS5	6,900
SL-BS-L	5	30	85	BS5	5,100
SL-BS-L	5	40	95	BS5	5,900
SL-BS-L	5	50	105	BS5	7,000
SL-BS-L	6	30	85	BS5	5,100
SL-BS-L	6	40	95	BS5	5,900
SL-BS-L	6	50	105	BS5	7,000
SL-BS-L	6	60	115	BS5	8,600
SL-BS-L	6	80	135	BS5	10,200
SL-BS-L	7	30	85	BS5	5,100
SL-BS-L	7	40	95	BS5	5,900
SL-BS-L	7	50	105	BS5	7,000
SL-BS-L	7	60	115	BS5	8,600
SL-BS-L	7	80	135	BS5	10,200
SL-BS-L	8	30	85	BS5	5,100
SL-BS-L	8	40	95	BS5	5,900
SL-BS-L	8	50	105	BS5	7,000
SL-BS-L	8	60	115	BS5	8,600
SL-BS-L	8	80	135	BS5	10,200
SL-BS-L	9	30	85	BS5	5,800
SL-BS-L	9	40	95	BS5	6,600
SL-BS-L	9	50	105	BS5	7,700
SL-BS-L	9	60	115	BS5	9,300

型番	刃径 (D)	刃長 (ℓ)	全長 (L)	シャンク	標準価格
SL-BS-L	9	80	135	BS5	11,300
SL-BS-L	10	30	85	BS5	5,800
SL-BS-L	10	40	95	BS5	6,600
SL-BS-L	10	50	105	BS5	7,700
SL-BS-L	10	60	115	BS5	9,300
SL-BS-L	10	80	135	BS5	11,300
SL-BS-L	11	30	85	BS5	6,600
SL-BS-L	11	40	95	BS5	6,900
SL-BS-L	11	50	105	BS5	8,100
SL-BS-L	11	60	115	BS5	9,700
SL-BS-L	12	30	85	BS5	6,600
SL-BS-L	12	40	95	BS5	6,900
SL-BS-L	12	50	105	BS5	8,100
SL-BS-L	12	60	115	BS5	9,700
SL-BS-L	12	80	135	BS5	11,600
SL-BS-L	13	40	95	BS5	7,700
SL-BS-L	13	50	105	BS5	8,300
SL-BS-L	13	60	115	BS5	9,100
SL-BS-L	14	40	95	BS5	7,700
SL-BS-L	14	50	105	BS5	8,300
SL-BS-L	14	60	115	BS5	9,100
SL-BS-L	15	40	95	BS5	7,700
SL-BS-L	15	50	105	BS5	9,000
SL-BS-L	15	60	115	BS5	10,000

特定代理店在庫

# (SP-MT) スパイラルエンドミル

Left Hand Spiral End Mills, MT Shank

材質=HSS  
リード角=左捩れ12°  
刃径公差=0~+0.2

刃数  
φ 3 4枚  
φ 4~14 6枚  
φ 15 8枚

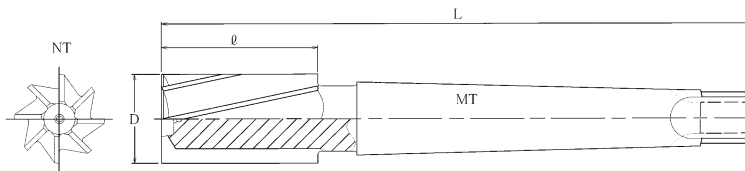

MT1シャンク

●注文例=型番、刃径、シャンク、数量「SP-MT 3xMT1」

型番	刃径 (D)	刃長 (ℓ)	全長 (L)	シャンク	標準価格
SP-MT	3	14	86	MT1	5,300
SP-MT	4	16	88	MT1	5,300
SP-MT	5	18	90	MT1	5,300
SP-MT	6	20	92	MT1	5,300
SP-MT	7	20	92	MT1	5,800
SP-MT	8	20	92	MT1	5,800
SP-MT	9	22	94	MT1	5,900

型番	刃径 (D)	刃長 (ℓ)	全長 (L)	シャンク	標準価格
SP-MT	10	22	94	MT1	5,900
SP-MT	11	24	96	MT1	6,900
SP-MT	12	26	96	MT1	6,900
SP-MT	13	26	98	MT1	7,400
SP-MT	14	26	98	MT1	8,100
SP-MT	15	26	98	MT1	8,100

特定代理店在庫

# (SP-BS) スパイラルエンドミル

Left Hand Spiral End Mills, BS Shank

SINCE 1935  
F.K.D.®

材質=HSS  
リード角=左振り12°  
刃径公差=0~+0.2

刃数  
φ 3~ 3.5 4枚  
φ 4~14.5 6枚  
φ 15 8枚

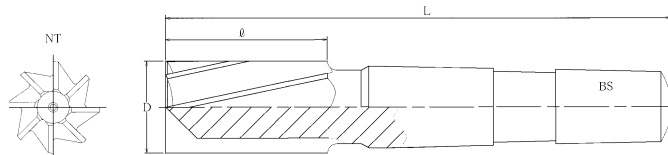

BS5シャンク

●注用例=型番、刃径、シャンク、数量「SP-BS 3xBS5」

型番	刃径 (D)	刃長 (ℓ)	全長 (L)	シャンク	標準価格
SP-BS	3	14	69	BS5	3,800
SP-BS	3.5	16	71	BS5	3,800
SP-BS	4	16	71	BS5	3,800
SP-BS	4.5	18	73	BS5	3,800
SP-BS	5	18	73	BS5	3,800
SP-BS	5.5	20	75	BS5	3,800
SP-BS	6	20	75	BS5	3,800
SP-BS	6.5	20	75	BS5	3,800
SP-BS	7	20	75	BS5	3,800
SP-BS	7.5	20	75	BS5	3,800
SP-BS	8	20	75	BS5	3,800
SP-BS	8.5	22	77	BS5	3,800
SP-BS	9	22	77	BS5	3,800
SP-BS	9.5	22	77	BS5	4,300
SP-BS	10	22	77	BS5	4,300
SP-BS	10.5	24	79	BS5	5,300

型番	刃径 (D)	刃長 (ℓ)	全長 (L)	シャンク	標準価格
SP-BS	11	24	79	BS5	5,300
SP-BS	11.5	26	81	BS5	5,300
SP-BS	12	26	81	BS5	5,300
SP-BS	12.5	26	81	BS5	6,100
SP-BS	13	26	81	BS5	6,100
SP-BS	13.5	26	81	BS5	6,600
SP-BS	14	26	81	BS5	6,600
SP-BS	14.5	26	81	BS5	6,600
SP-BS	15	26	81	BS5	6,600
SP-BS	1/8"	14	69	BS5	3,800
SP-BS	3/16"	18	73	BS5	3,800
SP-BS	1/4"	20	75	BS5	3,800
SP-BS	5/16"	20	75	BS5	3,800
SP-BS	3/8"	22	77	BS5	4,300
SP-BS	1/2"	26	81	BS5	6,100
SP-BS	9/16"	26	81	BS5	6,600

特定代理店在庫

# (SP-BS-L) ロングスパイラルエンドミル

Left Hand, Long Flute Spiral End Mills, BS Shank

材質=HSS  
リード角=左振り12°  
刃径公差=0~+0.2

刃数  
φ 3 4枚  
φ 4~14 6枚  
φ 15 8枚

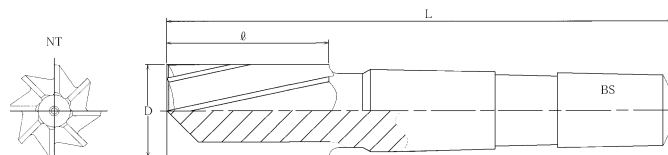

BS5シャンク

●注用例=型番、刃径、刃長、シャンク、数量「SP-BS-L 3x30xBS5」

型番	刃径 (D)	刃長 (ℓ)	全長 (L)	シャンク	標準価格
SP-BS-L	3	30	85	BS5	5,600
SP-BS-L	4	30	85	BS5	5,600
SP-BS-L	4	40	95	BS5	6,900
SP-BS-L	5	30	85	BS5	5,100
SP-BS-L	5	40	95	BS5	5,900
SP-BS-L	5	50	105	BS5	7,000
SP-BS-L	6	30	85	BS5	5,100
SP-BS-L	6	40	95	BS5	5,900
SP-BS-L	6	50	105	BS5	7,000
SP-BS-L	6	60	115	BS5	8,600
SP-BS-L	6	80	135	BS5	10,200
SP-BS-L	7	30	85	BS5	5,100
SP-BS-L	7	40	95	BS5	5,900
SP-BS-L	7	50	105	BS5	7,000
SP-BS-L	7	60	115	BS5	8,600
SP-BS-L	7	80	135	BS5	10,200
SP-BS-L	8	30	85	BS5	5,100
SP-BS-L	8	40	95	BS5	5,900
SP-BS-L	8	50	105	BS5	7,000
SP-BS-L	8	60	115	BS5	8,600
SP-BS-L	8	80	135	BS5	10,200
SP-BS-L	9	30	85	BS5	5,800
SP-BS-L	9	40	95	BS5	6,600

型番	刃径 (D)	刃長 (ℓ)	全長 (L)	シャンク	標準価格
SP-BS-L	9	50	105	BS5	7,700
SP-BS-L	9	60	115	BS5	9,300
SP-BS-L	10	30	85	BS5	5,800
SP-BS-L	10	40	95	BS5	6,600
SP-BS-L	10	50	105	BS5	7,700
SP-BS-L	10	60	115	BS5	9,300
SP-BS-L	10	80	135	BS5	11,300
SP-BS-L	11	30	85	BS5	6,600
SP-BS-L	11	40	95	BS5	6,900
SP-BS-L	11	50	105	BS5	8,100
SP-BS-L	11	60	115	BS5	9,700
SP-BS-L	12	30	85	BS5	6,600
SP-BS-L	12	40	95	BS5	6,900
SP-BS-L	12	50	105	BS5	8,100
SP-BS-L	12	60	115	BS5	9,700
SP-BS-L	12	80	135	BS5	11,600
SP-BS-L	13	40	95	BS5	7,700
SP-BS-L	13	50	105	BS5	8,300
SP-BS-L	14	40	95	BS5	7,700
SP-BS-L	14	50	105	BS5	8,300
SP-BS-L	15	40	95	BS5	7,700
SP-BS-L	15	50	105	BS5	9,000



# (KC) キーシートカッター

SINCE 1935  
F.K.D.®

Woodruff Keyseat Cutters

刃径公差 D ≤ 16 +0.18 ~ +0.30  
 16 < D ≤ 26 +0.21 ~ +0.35  
 26 < D ≤ 45 +0.26 ~ +0.43  
 45 < D ≤ 70 +0.30 ~ +0.50  
 刃幅公差  $\varnothing < 4$  -0.014 ~ -0.028  
 4 ≤  $\varnothing < 7$  -0.020 ~ -0.038  
 7 ≤  $\varnothing \leq 12$  -0.025 ~ -0.047

刃数  
 $\varnothing 6 \sim 13$  8枚  
 $\varnothing 14 \sim 16$  10枚  
 $\varnothing 18 \sim 22$  12枚  
 $\varnothing 24 \sim 32$  14枚  
 $\varnothing 35 \sim 55$  16枚  
 $\varnothing 60 \sim 70$  18枚

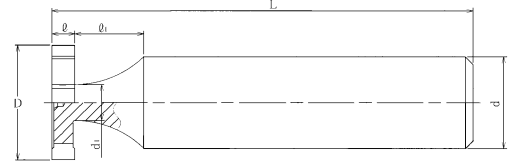
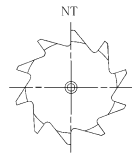

材質=HSS

●注文例=型番、刃径、刃幅、数量「KC 6x0.5」

型番	刃径 (D)	刃幅 (ℓ)	首径 (d1)	首長 (ℓ1)	全長 (L)	シャンク径 (d)	標準価格
KC	6	0.5	3	6	50	6	10,200
KC	6	0.6	3	6	50	6	10,200
KC	6	0.7	3	6	50	6	10,200
KC	6	0.8	3	6	50	6	10,200
KC	6	0.9	3	6	50	6	10,200
KC	6	1	3	6	50	6	8,900
KC	6	1.1	3	6	50	6	8,900
KC	6	1.2	3	6	50	6	8,900
KC	6	1.3	3	6	50	6	8,900
KC	6	1.4	3	6	50	6	8,900
KC	6	1.5	3	6	50	6	8,900
KC	6	1.6	3	6	50	6	8,900
KC	6	1.7	3	6	50	6	8,900
KC	6	1.8	3	6	50	6	8,900
KC	6	1.9	3	6	50	6	8,900
KC	6	2	3	6	50	6	8,900
KC	6	2.5	3	6	50	6	8,900
KC	6	3	3	6	50	6	7,800
KC	6	4	3	6	50	6	7,800
KC	6	5	3	6	50	6	7,800
KC	7	0.5	3	6	50	6	10,200
KC	7	0.6	3	6	50	6	10,200
KC	7	0.7	3	6	50	6	10,200
KC	7	0.8	3	6	50	6	10,200
KC	7	0.9	3	6	50	6	10,200
KC	7	1	3	6	50	6	8,900
KC	7	1.1	3	6	50	6	8,900
KC	7	1.2	3	6	50	6	8,900
KC	7	1.3	3	6	50	6	8,900
KC	7	1.4	3	6	50	6	8,900
KC	7	1.5	3	6	50	6	8,900
KC	7	1.6	3	6	50	6	8,900
KC	7	1.7	3	6	50	6	8,900
KC	7	1.8	3	6	50	6	8,900
KC	7	1.9	3	6	50	6	8,900
KC	7	2	3	6	50	6	8,900
KC	7	2.5	3	6	50	6	8,900
KC	7	3	3	6	50	6	7,800
KC	8	0.5	3.5	6	50	8	9,400
KC	8	0.6	3.5	6	50	8	9,400
KC	8	0.7	3.5	6	50	8	9,400
KC	8	0.8	3.5	6	50	8	9,400
KC	8	0.9	3.5	6	50	8	9,400
KC	8	1	3.5	6	50	8	7,800
KC	8	1.1	3.5	6	50	8	7,800
KC	8	1.2	3.5	6	50	8	7,800
KC	8	1.3	3.5	6	50	8	7,800

型番	刃径 (D)	刃幅 (ℓ)	首径 (d1)	首長 (ℓ1)	全長 (L)	シャンク径 (d)	標準価格
KC	8	1.4	3.5	6	50	8	7,800
KC	8	1.5	3.5	6	50	8	7,800
KC	8	1.6	3.5	6	50	8	7,800
KC	8	1.7	3.5	6	50	8	7,800
KC	8	1.8	3.5	6	50	8	7,800
KC	8	1.9	3.5	6	50	8	7,800
KC	8	2	3.5	6	50	8	7,800
KC	8	2.1	3.5	6	50	8	7,800
KC	8	2.2	3.5	6	50	8	7,800
KC	8	2.3	3.5	6	50	8	7,800
KC	8	2.4	3.5	6	50	8	7,800
KC	8	2.5	3.5	6	50	8	7,800
KC	8	2.6	3.5	6	50	8	7,800
KC	8	2.7	3.5	6	50	8	7,800
KC	8	2.8	3.5	6	50	8	7,800
KC	8	2.9	3.5	6	50	8	7,800
KC	8	3	3.5	6	50	8	7,400
KC	8	3.5	3.5	6	50	8	7,400
KC	8	4	3.5	6	50	8	7,400
KC	8	4.5	3.5	6	50	8	7,400
KC	8	5	3.5	6	50	8	7,400
KC	8	5.5	3.5	6	50	8	7,400
KC	8	6	3.5	6	50	8	7,400
KC	10	0.5	4.2	7	50	8	9,400
KC	10	0.6	4.2	7	50	8	9,400
KC	10	0.7	4.2	7	50	8	9,400
KC	10	0.8	4.2	7	50	8	9,400
KC	10	0.9	4.2	7	50	8	9,400
KC	10	1	4.2	7	50	8	7,800
KC	10	1.1	4.2	7	50	8	7,800
KC	10	1.2	4.2	7	50	8	7,800
KC	10	1.3	4.2	7	50	8	7,800
KC	10	1.4	4.2	7	50	8	7,800
KC	10	1.5	4.2	7	50	8	7,800
KC	10	1.6	4.2	7	50	8	7,800
KC	10	1.7	4.2	7	50	8	7,800
KC	10	1.8	4.2	7	50	8	7,800
KC	10	1.9	4.2	7	50	8	7,800
KC	10	2	4.2	7	50	8	7,800
KC	10	2.1	4.2	7	50	8	7,800
KC	10	2.2	4.2	7	50	8	7,800
KC	10	2.3	4.2	7	50	8	7,800
KC	10	2.4	4.2	7	50	8	7,800
KC	10	2.5	4.2	7	50	8	7,800
KC	10	2.6	4.2	7	50	8	7,800
KC	10	2.7	4.2	7	50	8	7,800
KC	10	2.8	4.2	7	50	8	7,800

# (KC) キーシートカッター

Woodruff Keyseat Cutters

SINCE 1935  
F.K.D.®

刃径公差 D ≤ 16 +0.18 ~ +0.30  
 16 < D ≤ 26 +0.21 ~ +0.35  
 26 < D ≤ 45 +0.26 ~ +0.43  
 45 < D ≤ 70 +0.30 ~ +0.50  
 刃幅公差  $\varnothing < 4$  -0.014 ~ -0.028  
 4 ≤  $\varnothing < 7$  -0.020 ~ -0.038  
 7 ≤  $\varnothing \leq 12$  -0.025 ~ -0.047

刃数  
 $\varnothing 6 \sim 13$  8枚  
 $\varnothing 14 \sim 16$  10枚  
 $\varnothing 18 \sim 22$  12枚  
 $\varnothing 24 \sim 32$  14枚  
 $\varnothing 35 \sim 55$  16枚  
 $\varnothing 60 \sim 70$  18枚

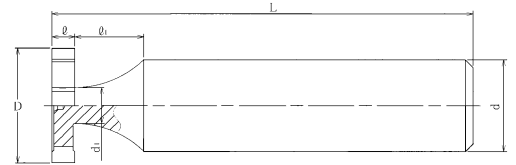
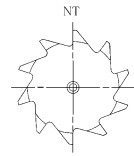

材質=HSS

●注文例=型番、刃径、刃幅、数量「KC 10x2.9」

型番	刃径 (D)	刃幅 (ℓ)	首径 (d1)	首長 (ℓ1)	全長 (L)	シャンク径 (d)	標準価格
KC	10	2.9	4.2	7	50	8	7,800
KC	10	3	4.2	7	50	8	7,400
KC	10	3.5	4.2	7	50	8	7,400
KC	10	4	4.2	7	50	8	7,400
KC	10	4.5	4.2	7	50	8	7,400
KC	10	5	4.2	7	50	8	7,400
KC	12	0.5	4.4	8	50	10	9,400
KC	12	0.6	4.4	8	50	10	9,400
KC	12	0.7	4.4	8	50	10	9,400
KC	12	0.8	4.4	8	50	10	9,400
KC	12	0.9	4.4	8	50	10	9,400
KC	12	1	4.4	8	50	10	7,800
KC	12	1.1	4.4	8	50	10	7,800
KC	12	1.2	4.4	8	50	10	7,800
KC	12	1.3	4.4	8	50	10	7,800
KC	12	1.4	4.4	8	50	10	7,800
KC	12	1.5	4.4	8	50	10	7,800
KC	12	1.6	4.4	8	50	10	7,800
KC	12	1.7	4.4	8	50	10	7,800
KC	12	1.8	4.4	8	50	10	7,800
KC	12	1.9	4.4	8	50	10	7,800
KC	12	2	4.4	8	50	10	7,800
KC	12	2.1	4.4	8	50	10	7,800
KC	12	2.2	4.4	8	50	10	7,800
KC	12	2.3	4.4	8	50	10	7,800
KC	12	2.4	4.4	8	50	10	7,800
KC	12	2.5	4.4	8	50	10	7,800
KC	12	2.6	4.4	8	50	10	7,800
KC	12	2.7	4.4	8	50	10	7,800
KC	12	2.8	4.4	8	50	10	7,800
KC	12	2.9	4.4	8	50	10	7,800
KC	12	3	4.4	8	50	10	7,400
KC	12	3.5	4.4	8	50	10	7,400
KC	12	4	4.4	8	50	10	7,400
KC	12	4.5	4.4	8	50	10	7,400
KC	12	5	4.4	8	50	10	7,400
KC	12	5.5	4.4	8	50	10	7,400
KC	12	6	4.4	8	50	10	7,400
KC	12	6.5	4.4	8	50	10	7,400
KC	12	7	4.4	8	50	10	7,400
KC	12	7.5	4.4	8	50	10	7,400
KC	12	8	4.4	8	50	10	7,400
KC	13	0.5	4.5	8	55	10	9,400
KC	13	0.6	4.5	8	55	10	9,400
KC	13	0.7	4.5	8	55	10	9,400
KC	13	0.8	4.5	8	55	10	9,400
KC	13	0.9	4.5	8	55	10	9,400

型番	刃径 (D)	刃幅 (ℓ)	首径 (d1)	首長 (ℓ1)	全長 (L)	シャンク径 (d)	標準価格
KC	13	1	4.5	8	55	10	7,800
KC	13	1.1	4.5	8	55	10	7,800
KC	13	1.2	4.5	8	55	10	7,800
KC	13	1.3	4.5	8	55	10	7,800
KC	13	1.4	4.5	8	55	10	7,800
KC	13	1.5	4.5	8	55	10	7,800
KC	13	1.6	4.5	8	55	10	7,800
KC	13	1.7	4.5	8	55	10	7,800
KC	13	1.8	4.5	8	55	10	7,800
KC	13	1.9	4.5	8	55	10	7,800
KC	13	2	4.5	8	55	10	7,800
KC	13	2.1	4.5	8	55	10	7,800
KC	13	2.2	4.5	8	55	10	7,800
KC	13	2.3	4.5	8	55	10	7,800
KC	13	2.4	4.5	8	55	10	7,800
KC	13	2.5	4.5	8	55	10	7,800
KC	13	2.6	4.5	8	55	10	7,800
KC	13	2.7	4.5	8	55	10	7,800
KC	13	2.8	4.5	8	55	10	7,800
KC	13	2.9	4.5	8	55	10	7,800
KC	13	3	4.5	8	55	10	7,400
KC	13	3.5	4.5	8	55	10	7,400
KC	13	4	4.5	8	55	10	7,400
KC	13	4.5	4.5	8	55	10	7,400
KC	13	5	4.5	8	55	10	7,400
KC	13	5.5	4.5	8	55	10	7,400
KC	13	6	4.5	8	55	10	7,400
KC	13	6.5	4.5	8	55	10	7,400
KC	13	7	4.5	8	55	10	7,400
KC	13	7.5	4.5	8	55	10	7,400
KC	13	8	4.5	8	55	10	7,400
KC	14	0.5	4.5	8.5	55	10	10,500
KC	14	0.6	4.5	8.5	55	10	10,500
KC	14	0.7	4.5	8.5	55	10	10,500
KC	14	0.8	4.5	8.5	55	10	10,500
KC	14	0.9	4.5	8.5	55	10	10,500
KC	14	1	4.5	8.5	55	10	9,000
KC	14	1.1	4.5	8.5	55	10	9,000
KC	14	1.2	4.5	8.5	55	10	9,000
KC	14	1.3	4.5	8.5	55	10	9,000
KC	14	1.4	4.5	8.5	55	10	9,000
KC	14	1.5	4.5	8.5	55	10	9,000
KC	14	1.6	4.5	8.5	55	10	9,000
KC	14	1.7	4.5	8.5	55	10	9,000
KC	14	1.8	4.5	8.5	55	10	9,000
KC	14	1.9	4.5	8.5	55	10	9,000
KC	14	2	4.5	8.5	55	10	9,000

# (KC) キーシートカッター

Woodruff Keyseat Cutters

SINCE 1935  
F.K.D.®

刃径公差 D ≤ 16 +0.18 ~ +0.30  
 16 < D ≤ 26 +0.21 ~ +0.35  
 26 < D ≤ 45 +0.26 ~ +0.43  
 45 < D ≤ 70 +0.30 ~ +0.50  
 刃幅公差  $\varnothing < 4$  -0.014 ~ -0.028  
 4 ≤  $\varnothing < 7$  -0.020 ~ -0.038  
 7 ≤  $\varnothing \leq 12$  -0.025 ~ -0.047

刃数  
 $\varnothing 6 \sim 13$  8枚  
 $\varnothing 14 \sim 16$  10枚  
 $\varnothing 18 \sim 22$  12枚  
 $\varnothing 24 \sim 32$  14枚  
 $\varnothing 35 \sim 55$  16枚  
 $\varnothing 60 \sim 70$  18枚

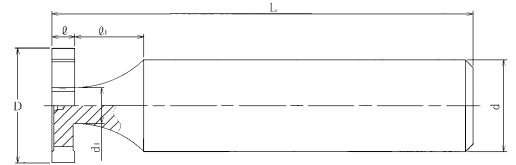
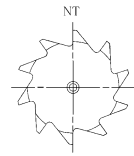

材質=HSS

●注文例=型番、刃径、刃幅、数量「KC 14x2.1」

型番	刃径 (D)	刃幅 ( $\varnothing$ )	首径 (d1)	首長 ( $\varnothing 1$ )	全長 (L)	シャンク径 (d)	標準価格
KC	14	2.1	4.5	8.5	55	10	9,000
KC	14	2.2	4.5	8.5	55	10	9,000
KC	14	2.3	4.5	8.5	55	10	9,000
KC	14	2.4	4.5	8.5	55	10	9,000
KC	14	2.5	4.5	8.5	55	10	9,000
KC	14	2.6	4.5	8.5	55	10	9,000
KC	14	2.7	4.5	8.5	55	10	9,000
KC	14	2.8	4.5	8.5	55	10	9,000
KC	14	2.9	4.5	8.5	55	10	9,000
KC	14	3	4.5	8.5	55	10	8,400
KC	14	3.5	4.5	8.5	55	10	8,400
KC	14	4	4.5	8.5	55	10	8,400
KC	14	4.5	4.5	8.5	55	10	8,400
KC	14	5	4.5	8.5	55	10	8,400
KC	14	5.5	4.5	8.5	55	10	8,400
KC	14	6	4.5	8.5	55	10	8,400
KC	14	6.5	4.5	8.5	55	10	8,400
KC	14	7	4.5	8.5	55	10	8,400
KC	14	7.5	4.5	8.5	55	10	8,400
KC	14	8	4.5	8.5	55	10	8,400
KC	15	0.5	4.7	9	55	12	10,500
KC	15	0.6	4.7	9	55	12	10,500
KC	15	0.7	4.7	9	55	12	10,500
KC	15	0.8	4.7	9	55	12	10,500
KC	15	0.9	4.7	9	55	12	10,500
KC	15	1	4.7	9	55	12	9,000
KC	15	1.1	4.7	9	55	12	9,000
KC	15	1.2	4.7	9	55	12	9,000
KC	15	1.3	4.7	9	55	12	9,000
KC	15	1.4	4.7	9	55	12	9,000
KC	15	1.5	4.7	9	55	12	9,000
KC	15	1.6	4.7	9	55	12	9,000
KC	15	1.7	4.7	9	55	12	9,000
KC	15	1.8	4.7	9	55	12	9,000
KC	15	1.9	4.7	9	55	12	9,000
KC	15	2	4.7	9	55	12	9,000
KC	15	2.1	4.7	9	55	12	9,000
KC	15	2.2	4.7	9	55	12	9,000
KC	15	2.3	4.7	9	55	12	9,000
KC	15	2.4	4.7	9	55	12	9,000
KC	15	2.5	4.7	9	55	12	9,000
KC	15	2.6	4.7	9	55	12	9,000
KC	15	2.7	4.7	9	55	12	9,000
KC	15	2.8	4.7	9	55	12	9,000
KC	15	2.9	4.7	9	55	12	9,000
KC	15	3	4.7	9	55	12	8,400
KC	15	3.5	4.7	9	55	12	8,400

型番	刃径 (D)	刃幅 ( $\varnothing$ )	首径 (d1)	首長 ( $\varnothing 1$ )	全長 (L)	シャンク径 (d)	標準価格
KC	15	4	4.7	9	55	12	8,400
KC	15	4.5	4.7	9	55	12	8,400
KC	15	5	4.7	9	55	12	8,400
KC	15	5.5	4.7	9	55	12	8,400
KC	15	6	4.7	9	55	12	8,400
KC	15	6.5	4.7	9	55	12	8,400
KC	15	7	4.7	9	55	12	8,400
KC	15	7.5	4.7	9	55	12	8,400
KC	15	8	4.7	9	55	12	8,400
KC	16	0.5	5	9	55	12	11,600
KC	16	0.6	5	9	55	12	11,600
KC	16	0.7	5	9	55	12	11,600
KC	16	0.8	5	9	55	12	11,600
KC	16	0.9	5	9	55	12	11,600
KC	16	1	5	9	55	12	9,800
KC	16	1.1	5	9	55	12	9,800
KC	16	1.2	5	9	55	12	9,800
KC	16	1.3	5	9	55	12	9,800
KC	16	1.4	5	9	55	12	9,800
KC	16	1.5	5	9	55	12	9,800
KC	16	1.6	5	9	55	12	9,800
KC	16	1.7	5	9	55	12	9,800
KC	16	1.8	5	9	55	12	9,800
KC	16	1.9	5	9	55	12	9,800
KC	16	2	5	9	55	12	9,800
KC	16	2.1	5	9	55	12	9,800
KC	16	2.2	5	9	55	12	9,800
KC	16	2.3	5	9	55	12	9,800
KC	16	2.4	5	9	55	12	9,800
KC	16	2.5	5	9	55	12	9,800
KC	16	2.6	5	9	55	12	9,800
KC	16	2.7	5	9	55	12	9,800
KC	16	2.8	5	9	55	12	9,800
KC	16	2.9	5	9	55	12	9,800
KC	16	3	5	9	55	12	9,000
KC	16	3.5	5	9	55	12	9,000
KC	16	4	5	9	55	12	9,000
KC	16	4.5	5	9	55	12	9,000
KC	16	5	5	9	55	12	9,000
KC	16	5.5	5	9	55	12	9,000
KC	16	6	5	9	55	12	9,000
KC	16	6.5	5	9	55	12	9,000
KC	16	7	5	9	55	12	9,000
KC	16	7.5	5	9	55	12	9,000
KC	16	8	5	9	55	12	9,000
KC	16	10	5	9	55	12	9,000
KC	18	0.5	7	9.5	55	12	12,900

# (KC) キーシートカッター

Woodruff Keyseat Cutters

SINCE 1935  
F.K.D.®

刃径公差 D ≤ 16 +0.18 ~ +0.30  
 16 < D ≤ 26 +0.21 ~ +0.35  
 26 < D ≤ 45 +0.26 ~ +0.43  
 45 < D ≤ 70 +0.30 ~ +0.50  
 刃幅公差  $\varnothing < 4$  -0.014 ~ -0.028  
 4 ≤  $\varnothing < 7$  -0.020 ~ -0.038  
 7 ≤  $\varnothing \leq 12$  -0.025 ~ -0.047

刃数  
 $\varnothing 6 \sim 13$  8枚  
 $\varnothing 14 \sim 16$  10枚  
 $\varnothing 18 \sim 22$  12枚  
 $\varnothing 24 \sim 32$  14枚  
 $\varnothing 35 \sim 55$  16枚  
 $\varnothing 60 \sim 70$  18枚

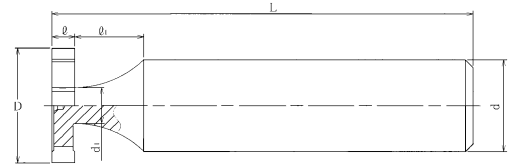
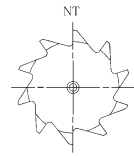

材質=HSS

●注文例=型番、刃径、刃幅、数量「KC 18x0.6」

型番	刃径 (D)	刃幅 (ℓ)	首径 (d1)	首長 (ℓ1)	全長 (L)	シャンク径 (d)	標準価格
KC	18	0.6	7	9.5	55	12	12,900
KC	18	0.7	7	9.5	55	12	12,900
KC	18	0.8	7	9.5	55	12	12,900
KC	18	0.9	7	9.5	55	12	12,900
KC	18	1	7	9.5	55	12	11,000
KC	18	1.1	7	9.5	55	12	11,000
KC	18	1.2	7	9.5	55	12	11,000
KC	18	1.3	7	9.5	55	12	11,000
KC	18	1.4	7	9.5	55	12	11,000
KC	18	1.5	7	9.5	55	12	11,000
KC	18	1.6	7	9.5	55	12	11,000
KC	18	1.7	7	9.5	55	12	11,000
KC	18	1.8	7	9.5	55	12	11,000
KC	18	1.9	7	9.5	55	12	11,000
KC	18	2	7	9.5	55	12	11,000
KC	18	2.1	7	9.5	55	12	11,000
KC	18	2.2	7	9.5	55	12	11,000
KC	18	2.3	7	9.5	55	12	11,000
KC	18	2.4	7	9.5	55	12	11,000
KC	18	2.5	7	9.5	55	12	11,000
KC	18	2.6	7	9.5	55	12	11,000
KC	18	2.7	7	9.5	55	12	11,000
KC	18	2.8	7	9.5	55	12	11,000
KC	18	2.9	7	9.5	55	12	11,000
KC	18	3	7	9.5	55	12	10,000
KC	18	3.5	7	9.5	55	12	10,000
KC	18	4	7	9.5	55	12	10,000
KC	18	4.5	7	9.5	55	12	10,000
KC	18	5	7	9.5	55	12	10,000
KC	18	5.5	7	9.5	55	12	10,000
KC	18	6	7	9.5	55	12	10,000
KC	18	6.5	7	9.5	55	12	10,000
KC	18	7	7	9.5	55	12	10,000
KC	18	7.5	7	9.5	55	12	10,000
KC	18	8	7	9.5	55	12	10,000
KC	19	0.5	7.5	10	55	12	14,300
KC	19	0.6	7.5	10	55	12	14,300
KC	19	0.7	7.5	10	55	12	14,300
KC	19	0.8	7.5	10	55	12	14,300
KC	19	0.9	7.5	10	55	12	14,300
KC	19	1	7.5	10	55	12	12,300
KC	19	1.1	7.5	10	55	12	12,300
KC	19	1.2	7.5	10	55	12	12,300
KC	19	1.3	7.5	10	55	12	12,300
KC	19	1.4	7.5	10	55	12	12,300
KC	19	1.5	7.5	10	55	12	12,300
KC	19	1.6	7.5	10	55	12	12,300

型番	刃径 (D)	刃幅 (ℓ)	首径 (d1)	首長 (ℓ1)	全長 (L)	シャンク径 (d)	標準価格
KC	19	1.7	7.5	10	55	12	12,300
KC	19	1.8	7.5	10	55	12	12,300
KC	19	1.9	7.5	10	55	12	12,300
KC	19	2	7.5	10	55	12	12,300
KC	19	2.1	7.5	10	55	12	12,300
KC	19	2.2	7.5	10	55	12	12,300
KC	19	2.3	7.5	10	55	12	12,300
KC	19	2.4	7.5	10	55	12	12,300
KC	19	2.5	7.5	10	55	12	12,300
KC	19	2.6	7.5	10	55	12	12,300
KC	19	2.7	7.5	10	55	12	12,300
KC	19	2.8	7.5	10	55	12	12,300
KC	19	2.9	7.5	10	55	12	12,300
KC	19	3	7.5	10	55	12	11,200
KC	19	3.5	7.5	10	55	12	11,200
KC	19	4	7.5	10	55	12	11,200
KC	19	4.5	7.5	10	55	12	11,200
KC	19	5	7.5	10	55	12	11,200
KC	19	5.5	7.5	10	55	12	11,200
KC	19	6	7.5	10	55	12	11,200
KC	19	6.5	7.5	10	55	12	11,200
KC	19	7	7.5	10	55	12	11,200
KC	19	7.5	7.5	10	55	12	11,200
KC	19	8	7.5	10	55	12	11,200
KC	19	8.5	7.5	10	55	12	11,200
KC	19	9	7.5	10	55	12	11,200
KC	19	9.5	7.5	10	55	12	11,200
KC	19	10	7.5	10	55	12	11,200
KC	20	0.5	7.5	10	60	12	14,300
KC	20	0.6	7.5	10	60	12	14,300
KC	20	0.7	7.5	10	60	12	14,300
KC	20	0.8	7.5	10	60	12	14,300
KC	20	0.9	7.5	10	60	12	14,300
KC	20	1	7.5	10	60	12	12,300
KC	20	1.1	7.5	10	60	12	12,300
KC	20	1.2	7.5	10	60	12	12,300
KC	20	1.3	7.5	10	60	12	12,300
KC	20	1.4	7.5	10	60	12	12,300
KC	20	1.5	7.5	10	60	12	12,300
KC	20	1.6	7.5	10	60	12	12,300
KC	20	1.7	7.5	10	60	12	12,300
KC	20	1.8	7.5	10	60	12	12,300
KC	20	1.9	7.5	10	60	12	12,300
KC	20	2	7.5	10	60	12	12,300
KC	20	2.1	7.5	10	60	12	12,300
KC	20	2.2	7.5	10	60	12	12,300
KC	20	2.3	7.5	10	60	12	12,300

# (KC) キーシートカッター

Woodruff Keyseat Cutters

SINCE 1935  
F.K.D.®

刃径公差 D ≤ 16 +0.18 ~ +0.30  
 16 < D ≤ 26 +0.21 ~ +0.35  
 26 < D ≤ 45 +0.26 ~ +0.43  
 45 < D ≤ 70 +0.30 ~ +0.50  
 刃幅公差  $\varnothing < 4$  -0.014 ~ -0.028  
 4 ≤  $\varnothing < 7$  -0.020 ~ -0.038  
 7 ≤  $\varnothing \leq 12$  -0.025 ~ -0.047

刃数  
 $\varnothing 6 \sim 13$  8枚  
 $\varnothing 14 \sim 16$  10枚  
 $\varnothing 18 \sim 22$  12枚  
 $\varnothing 24 \sim 32$  14枚  
 $\varnothing 35 \sim 55$  16枚  
 $\varnothing 60 \sim 70$  18枚

材質=HSS

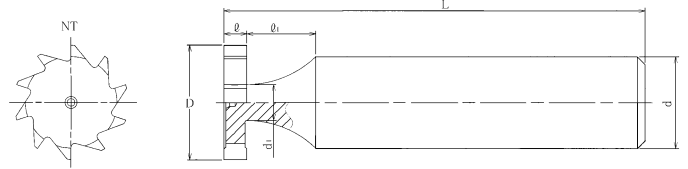

●注文例=型番、刃径、刃幅、数量「KC 20x2.4」

型番	刃径 (D)	刃幅 (ℓ)	首径 (d1)	首長 (ℓ1)	全長 (L)	シャンク径 (d)	標準価格
KC	20	2.4	7.5	10	60	12	12,300
KC	20	2.5	7.5	10	60	12	12,300
KC	20	2.6	7.5	10	60	12	12,300
KC	20	2.7	7.5	10	60	12	12,300
KC	20	2.8	7.5	10	60	12	12,300
KC	20	2.9	7.5	10	60	12	12,300
KC	20	3	7.5	10	60	12	11,200
KC	20	3.5	7.5	10	60	12	11,200
KC	20	4	7.5	10	60	12	11,200
KC	20	4.5	7.5	10	60	12	11,200
KC	20	5	7.5	10	60	12	11,200
KC	20	5.5	7.5	10	60	12	11,200
KC	20	6	7.5	10	60	12	11,200
KC	20	6.5	7.5	10	60	12	11,200
KC	20	7	7.5	10	60	12	11,200
KC	20	7.5	7.5	10	60	12	11,200
KC	20	8	7.5	10	60	12	11,200
KC	20	8.5	7.5	10	60	12	11,200
KC	20	9	7.5	10	60	12	11,200
KC	20	9.5	7.5	10	60	12	11,200
KC	20	10	7.5	10	60	12	11,200
KC	22	0.5	8	10	60	12	16,300
KC	22	0.6	8	10	60	12	16,300
KC	22	0.7	8	10	60	12	16,300
KC	22	0.8	8	10	60	12	16,300
KC	22	0.9	8	10	60	12	16,300
KC	22	1	8	10	60	12	13,800
KC	22	1.1	8	10	60	12	13,800
KC	22	1.2	8	10	60	12	13,800
KC	22	1.3	8	10	60	12	13,800
KC	22	1.4	8	10	60	12	13,800
KC	22	1.5	8	10	60	12	13,800
KC	22	1.6	8	10	60	12	13,800
KC	22	1.7	8	10	60	12	13,800
KC	22	1.8	8	10	60	12	13,800
KC	22	1.9	8	10	60	12	13,800
KC	22	2	8	10	60	12	13,800
KC	22	2.1	8	10	60	12	13,800
KC	22	2.2	8	10	60	12	13,800
KC	22	2.3	8	10	60	12	13,800
KC	22	2.4	8	10	60	12	13,800
KC	22	2.5	8	10	60	12	13,800
KC	22	2.6	8	10	60	12	13,800
KC	22	2.7	8	10	60	12	13,800
KC	22	2.8	8	10	60	12	13,800
KC	22	2.9	8	10	60	12	13,800
KC	22	3	8	10	60	12	12,400

型番	刃径 (D)	刃幅 (ℓ)	首径 (d1)	首長 (ℓ1)	全長 (L)	シャンク径 (d)	標準価格
KC	22	3.5	8	10	60	12	12,400
KC	22	4	8	10	60	12	12,400
KC	22	4.5	8	10	60	12	12,400
KC	22	5	8	10	60	12	12,400
KC	22	5.5	8	10	60	12	12,400
KC	22	6	8	10	60	12	12,400
KC	22	6.5	8	10	60	12	12,400
KC	22	7	8	10	60	12	12,400
KC	22	7.5	8	10	60	12	12,400
KC	22	8	8	10	60	12	12,400
KC	22	8.5	8	10	60	12	12,400
KC	22	9	8	10	60	12	12,400
KC	22	9.5	8	10	60	12	12,400
KC	22	10	8	10	60	12	12,400
KC	24	0.5	9	11	60	12	18,700
KC	24	0.6	9	11	60	12	18,700
KC	24	0.7	9	11	60	12	18,700
KC	24	0.8	9	11	60	12	18,700
KC	24	0.9	9	11	60	12	18,700
KC	24	1	9	11	60	12	16,100
KC	24	1.1	9	11	60	12	16,100
KC	24	1.2	9	11	60	12	16,100
KC	24	1.3	9	11	60	12	16,100
KC	24	1.4	9	11	60	12	16,100
KC	24	1.5	9	11	60	12	16,100
KC	24	1.6	9	11	60	12	16,100
KC	24	1.7	9	11	60	12	16,100
KC	24	1.8	9	11	60	12	16,100
KC	24	1.9	9	11	60	12	16,100
KC	24	2	9	11	60	12	16,100
KC	24	2.1	9	11	60	12	16,100
KC	24	2.2	9	11	60	12	16,100
KC	24	2.3	9	11	60	12	16,100
KC	24	2.4	9	11	60	12	16,100
KC	24	2.5	9	11	60	12	16,100
KC	24	2.6	9	11	60	12	16,100
KC	24	2.7	9	11	60	12	16,100
KC	24	2.8	9	11	60	12	16,100
KC	24	2.9	9	11	60	12	16,100
KC	24	3	9	11	60	12	14,400
KC	24	3.5	9	11	60	12	14,400
KC	24	4	9	11	60	12	14,400
KC	24	4.5	9	11	60	12	14,400
KC	24	5	9	11	60	12	14,400
KC	24	5.5	9	11	60	12	14,400
KC	24	6	9	11	60	12	14,400
KC	24	6.5	9	11	60	12	14,400

# (KC) キーシートカッター

Woodruff Keyseat Cutters

SINCE 1935  
F.K.D.®

刃径公差 D ≤ 16 +0.18 ~ +0.30  
 16 < D ≤ 26 +0.21 ~ +0.35  
 26 < D ≤ 45 +0.26 ~ +0.43  
 45 < D ≤ 70 +0.30 ~ +0.50  
 刃幅公差  $\varnothing < 4$  -0.014 ~ -0.028  
 4 ≤  $\varnothing < 7$  -0.020 ~ -0.038  
 7 ≤  $\varnothing \leq 12$  -0.025 ~ -0.047

刃数  
 $\phi$  6 ~ 13 8枚  
 $\phi$  14 ~ 16 10枚  
 $\phi$  18 ~ 22 12枚  
 $\phi$  24 ~ 32 14枚  
 $\phi$  35 ~ 55 16枚  
 $\phi$  60 ~ 70 18枚

材質=HSS

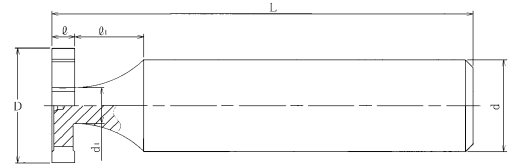
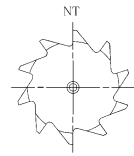

●注文例=型番、刃径、刃幅、数量「KC 24x7」

型番	刃径 (D)	刃幅 (ℓ)	首径 (d1)	首長 (ℓ1)	全長 (L)	シャンク径 (d)	標準価格
KC	24	7	9	11	60	12	14,400
KC	24	7.5	9	11	60	12	14,400
KC	24	8	9	11	60	12	14,400
KC	24	8.5	9	11	60	12	14,400
KC	24	9	9	11	60	12	14,400
KC	24	9.5	9	11	60	12	14,400
KC	24	10	9	11	60	12	14,400
KC	25	0.5	9	12	60	12	18,700
KC	25	0.6	9	12	60	12	18,700
KC	25	0.7	9	12	60	12	18,700
KC	25	0.8	9	12	60	12	18,700
KC	25	0.9	9	12	60	12	18,700
KC	25	1	9	12	60	12	16,100
KC	25	1.1	9	12	60	12	16,100
KC	25	1.2	9	12	60	12	16,100
KC	25	1.3	9	12	60	12	16,100
KC	25	1.4	9	12	60	12	16,100
KC	25	1.5	9	12	60	12	16,100
KC	25	1.6	9	12	60	12	16,100
KC	25	1.7	9	12	60	12	16,100
KC	25	1.8	9	12	60	12	16,100
KC	25	1.9	9	12	60	12	16,100
KC	25	2	9	12	60	12	16,100
KC	25	2.1	9	12	60	12	16,100
KC	25	2.2	9	12	60	12	16,100
KC	25	2.3	9	12	60	12	16,100
KC	25	2.4	9	12	60	12	16,100
KC	25	2.5	9	12	60	12	16,100
KC	25	2.6	9	12	60	12	16,100
KC	25	2.7	9	12	60	12	16,100
KC	25	2.8	9	12	60	12	16,100
KC	25	2.9	9	12	60	12	16,100
KC	25	3	9	12	60	12	14,400
KC	25	3.5	9	12	60	12	14,400
KC	25	4	9	12	60	12	14,400
KC	25	4.5	9	12	60	12	14,400
KC	25	5	9	12	60	12	14,400
KC	25	5.5	9	12	60	12	14,400
KC	25	6	9	12	60	12	14,400
KC	25	6.5	9	12	60	12	14,400
KC	25	7	9	12	60	12	14,400
KC	25	7.5	9	12	60	12	14,400
KC	25	8	9	12	60	12	14,400
KC	25	8.5	9	12	60	12	14,400
KC	25	9	9	12	60	12	14,400
KC	25	9.5	9	12	60	12	14,400
KC	25	10	9	12	60	12	14,400

型番	刃径 (D)	刃幅 (ℓ)	首径 (d1)	首長 (ℓ1)	全長 (L)	シャンク径 (d)	標準価格
KC	26	0.5	9	12	60	12	19,500
KC	26	0.6	9	12	60	12	19,500
KC	26	0.7	9	12	60	12	19,500
KC	26	0.8	9	12	60	12	19,500
KC	26	0.9	9	12	60	12	19,500
KC	26	1	9	12	60	12	16,600
KC	26	1.1	9	12	60	12	16,600
KC	26	1.2	9	12	60	12	16,600
KC	26	1.3	9	12	60	12	16,600
KC	26	1.4	9	12	60	12	16,600
KC	26	1.5	9	12	60	12	16,600
KC	26	1.6	9	12	60	12	16,600
KC	26	1.7	9	12	60	12	16,600
KC	26	1.8	9	12	60	12	16,600
KC	26	1.9	9	12	60	12	16,600
KC	26	2	9	12	60	12	16,600
KC	26	2.1	9	12	60	12	16,600
KC	26	2.2	9	12	60	12	16,600
KC	26	2.3	9	12	60	12	16,600
KC	26	2.4	9	12	60	12	16,600
KC	26	2.5	9	12	60	12	16,600
KC	26	2.6	9	12	60	12	16,600
KC	26	2.7	9	12	60	12	16,600
KC	26	2.8	9	12	60	12	16,600
KC	26	2.9	9	12	60	12	16,600
KC	26	3	9	12	60	12	15,000
KC	26	3.5	9	12	60	12	15,000
KC	26	4	9	12	60	12	15,000
KC	26	4.5	9	12	60	12	15,000
KC	26	5	9	12	60	12	15,000
KC	26	5.5	9	12	60	12	15,000
KC	26	6	9	12	60	12	15,000
KC	26	6.5	9	12	60	12	15,000
KC	26	7	9	12	60	12	15,000
KC	26	7.5	9	12	60	12	15,000
KC	26	8	9	12	60	12	15,000
KC	26	8.5	9	12	60	12	15,000
KC	26	9	9	12	60	12	15,000
KC	26	9.5	9	12	60	12	15,000
KC	26	10	9	12	60	12	15,000
KC	28	0.5	10	12	65	12	22,600
KC	28	0.6	10	12	65	12	22,600
KC	28	0.7	10	12	65	12	22,600
KC	28	0.8	10	12	65	12	22,600
KC	28	0.9	10	12	65	12	22,600
KC	28	1	10	12	65	12	19,100
KC	28	1.1	10	12	65	12	19,100

# (KC) キーシートカッター

Woodruff Keyseat Cutters

SINCE 1935  
F.K.D.®

刃径公差 D ≤ 16 +0.18 ~ +0.30  
 16 < D ≤ 26 +0.21 ~ +0.35  
 26 < D ≤ 45 +0.26 ~ +0.43  
 45 < D ≤ 70 +0.30 ~ +0.50  
 刃幅公差  $\varnothing < 4$  -0.014 ~ -0.028  
 4 ≤  $\varnothing < 7$  -0.020 ~ -0.038  
 7 ≤  $\varnothing \leq 12$  -0.025 ~ -0.047

刃数  
 $\phi$  6 ~ 13 8枚  
 $\phi$  14 ~ 16 10枚  
 $\phi$  18 ~ 22 12枚  
 $\phi$  24 ~ 32 14枚  
 $\phi$  35 ~ 55 16枚  
 $\phi$  60 ~ 70 18枚

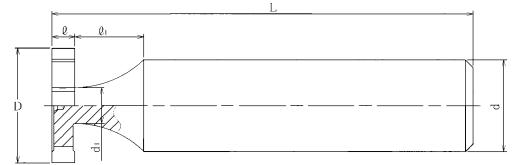
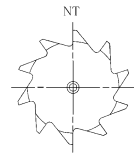

材質=HSS

●注文例=型番、刃径、刃幅、数量「KC 28x1.2」

型番	刃径 (D)	刃幅 (∅)	首径 (d1)	首長 (∅l1)	全長 (L)	シャンク径 (d)	標準価格
KC	28	1.2	10	12	65	12	19,100
KC	28	1.3	10	12	65	12	19,100
KC	28	1.4	10	12	65	12	19,100
KC	28	1.5	10	12	65	12	19,100
KC	28	1.6	10	12	65	12	19,100
KC	28	1.7	10	12	65	12	19,100
KC	28	1.8	10	12	65	12	19,100
KC	28	1.9	10	12	65	12	19,100
KC	28	2	10	12	65	12	19,100
KC	28	2.1	10	12	65	12	19,100
KC	28	2.2	10	12	65	12	19,100
KC	28	2.3	10	12	65	12	19,100
KC	28	2.4	10	12	65	12	19,100
KC	28	2.5	10	12	65	12	19,100
KC	28	2.6	10	12	65	12	19,100
KC	28	2.7	10	12	65	12	19,100
KC	28	2.8	10	12	65	12	19,100
KC	28	2.9	10	12	65	12	19,100
KC	28	3	10	12	65	12	17,500
KC	28	3.5	10	12	65	12	17,500
KC	28	4	10	12	65	12	17,500
KC	28	4.5	10	12	65	12	17,500
KC	28	5	10	12	65	12	17,500
KC	28	5.5	10	12	65	12	17,500
KC	28	6	10	12	65	12	17,500
KC	28	6.5	10	12	65	12	17,500
KC	28	7	10	12	65	12	17,500
KC	28	7.5	10	12	65	12	17,500
KC	28	8	10	12	65	12	17,500
KC	28	8.5	10	12	65	12	17,500
KC	28	9	10	12	65	12	17,500
KC	28	9.5	10	12	65	12	17,500
KC	28	10	10	12	65	12	17,500
KC	30	0.5	10	12	65	12	26,200
KC	30	0.6	10	12	65	12	26,200
KC	30	0.7	10	12	65	12	26,200
KC	30	0.8	10	12	65	12	26,200
KC	30	0.9	10	12	65	12	26,200
KC	30	1	10	12	65	12	22,000
KC	30	1.1	10	12	65	12	22,000
KC	30	1.2	10	12	65	12	22,000
KC	30	1.3	10	12	65	12	22,000
KC	30	1.4	10	12	65	12	22,000
KC	30	1.5	10	12	65	12	22,000
KC	30	1.6	10	12	65	12	22,000
KC	30	1.7	10	12	65	12	22,000
KC	30	1.8	10	12	65	12	22,000

型番	刃径 (D)	刃幅 (∅)	首径 (d1)	首長 (∅l1)	全長 (L)	シャンク径 (d)	標準価格
KC	30	1.9	10	12	65	12	22,000
KC	30	2	10	12	65	12	22,000
KC	30	2.1	10	12	65	12	22,000
KC	30	2.2	10	12	65	12	22,000
KC	30	2.3	10	12	65	12	22,000
KC	30	2.4	10	12	65	12	22,000
KC	30	2.5	10	12	65	12	22,000
KC	30	2.6	10	12	65	12	22,000
KC	30	2.7	10	12	65	12	22,000
KC	30	2.8	10	12	65	12	22,000
KC	30	2.9	10	12	65	12	22,000
KC	30	3	10	12	65	12	20,100
KC	30	3.5	10	12	65	12	20,100
KC	30	4	10	12	65	12	20,100
KC	30	4.5	10	12	65	12	20,100
KC	30	5	10	12	65	12	20,100
KC	30	5.5	10	12	65	12	20,100
KC	30	6	10	12	65	12	20,100
KC	30	6.5	10	12	65	12	20,100
KC	30	7	10	12	65	12	20,100
KC	30	7.5	10	12	65	12	20,100
KC	30	8	10	12	65	12	20,100
KC	30	8.5	10	12	65	12	20,100
KC	30	9	10	12	65	12	20,100
KC	30	9.5	10	12	65	12	20,100
KC	30	10	10	12	65	12	20,100
KC	30	12	10	12	65	12	20,100
KC	32	1	10	14	65	12	25,000
KC	32	1.1	10	14	65	12	25,000
KC	32	1.2	10	14	65	12	25,000
KC	32	1.3	10	14	65	12	25,000
KC	32	1.4	10	14	65	12	25,000
KC	32	1.5	10	14	65	12	25,000
KC	32	1.6	10	14	65	12	25,000
KC	32	1.7	10	14	65	12	25,000
KC	32	1.8	10	14	65	12	25,000
KC	32	1.9	10	14	65	12	25,000
KC	32	2	10	14	65	12	25,000
KC	32	2.1	10	14	65	12	25,000
KC	32	2.2	10	14	65	12	25,000
KC	32	2.3	10	14	65	12	25,000
KC	32	2.4	10	14	65	12	25,000
KC	32	2.5	10	14	65	12	25,000
KC	32	2.6	10	14	65	12	25,000
KC	32	2.7	10	14	65	12	25,000
KC	32	2.8	10	14	65	12	25,000
KC	32	2.9	10	14	65	12	25,000

# (KC) キーシートカッター

Woodruff Keyseat Cutters

SINCE 1935  
F.K.D.®

刃径公差 D ≤ 16 +0.18 ~ +0.30  
 16 < D ≤ 26 +0.21 ~ +0.35  
 26 < D ≤ 45 +0.26 ~ +0.43  
 45 < D ≤ 70 +0.30 ~ +0.50  
 刃幅公差  $\varnothing < 4$  -0.014 ~ -0.028  
 4 ≤  $\varnothing < 7$  -0.020 ~ -0.038  
 7 ≤  $\varnothing \leq 12$  -0.025 ~ -0.047

刃数  
 $\varnothing 6 \sim 13$  8枚  
 $\varnothing 14 \sim 16$  10枚  
 $\varnothing 18 \sim 22$  12枚  
 $\varnothing 24 \sim 32$  14枚  
 $\varnothing 35 \sim 55$  16枚  
 $\varnothing 60 \sim 70$  18枚

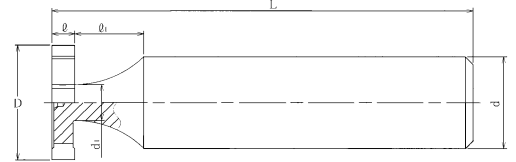
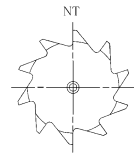

材質=HSS

●注文例=型番、刃径、刃幅、数量「KC 32x3」

型番	刃径 (D)	刃幅 (∅)	首径 (d1)	首長 (∅l)	全長 (L)	シャンク径 (d)	標準価格
KC	32	3	10	14	65	12	22,600
KC	32	3.5	10	14	65	12	22,600
KC	32	4	10	14	65	12	22,600
KC	32	4.5	10	14	65	12	22,600
KC	32	5	10	14	65	12	22,600
KC	32	5.5	10	14	65	12	22,600
KC	32	6	10	14	65	12	22,600
KC	32	6.5	10	14	65	12	22,600
KC	32	7	10	14	65	12	22,600
KC	32	7.5	10	14	65	12	22,600
KC	32	8	10	14	65	12	22,600
KC	32	8.5	10	14	65	12	22,600
KC	32	9	10	14	65	12	22,600
KC	32	9.5	10	14	65	12	22,600
KC	32	10	10	14	65	12	22,600
KC	32	12	10	14	65	12	22,600
KC	35	1	10	15	70	12	28,200
KC	35	1.1	10	15	70	12	28,200
KC	35	1.2	10	15	70	12	28,200
KC	35	1.3	10	15	70	12	28,200
KC	35	1.4	10	15	70	12	28,200
KC	35	1.5	10	15	70	12	28,200
KC	35	1.6	10	15	70	12	28,200
KC	35	1.7	10	15	70	12	28,200
KC	35	1.8	10	15	70	12	28,200
KC	35	1.9	10	15	70	12	28,200
KC	35	2	10	15	70	12	28,200
KC	35	2.1	10	15	70	12	28,200
KC	35	2.2	10	15	70	12	28,200
KC	35	2.3	10	15	70	12	28,200
KC	35	2.4	10	15	70	12	28,200
KC	35	2.5	10	15	70	12	28,200
KC	35	2.6	10	15	70	12	28,200
KC	35	2.7	10	15	70	12	28,200
KC	35	2.8	10	15	70	12	28,200
KC	35	2.9	10	15	70	12	28,200
KC	35	3	10	15	70	12	25,500
KC	35	3.5	10	15	70	12	25,500
KC	35	4	10	15	70	12	25,500
KC	35	4.5	10	15	70	12	25,500
KC	35	5	10	15	70	12	25,500
KC	35	5.5	10	15	70	12	25,500
KC	35	6	10	15	70	12	25,500
KC	35	6.5	10	15	70	12	25,500
KC	35	7	10	15	70	12	25,500
KC	35	7.5	10	15	70	12	25,500
KC	35	8	10	15	70	12	25,500

型番	刃径 (D)	刃幅 (∅)	首径 (d1)	首長 (∅l)	全長 (L)	シャンク径 (d)	標準価格
KC	35	8.5	10	15	70	12	25,500
KC	35	9	10	15	70	12	25,500
KC	35	9.5	10	15	70	12	25,500
KC	35	10	10	15	70	12	25,500
KC	35	12	10	15	70	12	25,500
KC	38	1	10.5	16	70	12	33,000
KC	38	1.5	10.5	16	70	12	33,000
KC	38	2	10.5	16	70	12	33,000
KC	38	2.5	10.5	16	70	12	33,000
KC	38	3	10.5	16	70	12	30,100
KC	38	3.5	10.5	16	70	12	30,100
KC	38	4	10.5	16	70	12	30,100
KC	38	4.5	10.5	16	70	12	30,100
KC	38	5	10.5	16	70	12	30,100
KC	38	5.5	10.5	16	70	12	30,100
KC	38	6	10.5	16	70	12	30,100
KC	38	6.5	10.5	16	70	12	30,100
KC	38	7	10.5	16	70	12	30,100
KC	38	7.5	10.5	16	70	12	30,100
KC	38	8	10.5	16	70	12	30,100
KC	38	8.5	10.5	16	70	12	30,100
KC	38	9	10.5	16	70	12	30,100
KC	38	9.5	10.5	16	70	12	30,100
KC	38	10	10.5	16	70	12	30,100
KC	38	12	10.5	16	70	12	30,100
KC	40	1	10.5	16	70	12	38,500
KC	40	1.1	10.5	16	70	12	38,500
KC	40	1.2	10.5	16	70	12	38,500
KC	40	1.3	10.5	16	70	12	38,500
KC	40	1.4	10.5	16	70	12	38,500
KC	40	1.5	10.5	16	70	12	38,500
KC	40	1.6	10.5	16	70	12	38,500
KC	40	1.7	10.5	16	70	12	38,500
KC	40	1.8	10.5	16	70	12	38,500
KC	40	1.9	10.5	16	70	12	38,500
KC	40	2	10.5	16	70	12	38,500
KC	40	2.1	10.5	16	70	12	38,500
KC	40	2.2	10.5	16	70	12	38,500
KC	40	2.3	10.5	16	70	12	38,500
KC	40	2.4	10.5	16	70	12	38,500
KC	40	2.5	10.5	16	70	12	38,500
KC	40	2.6	10.5	16	70	12	38,500
KC	40	2.7	10.5	16	70	12	38,500
KC	40	2.8	10.5	16	70	12	38,500
KC	40	2.9	10.5	16	70	12	38,500
KC	40	3	10.5	16	70	12	35,100
KC	40	3.5	10.5	16	70	12	35,100



# (KC) キーシートカッター

Woodruff Keyseat Cutters

SINCE 1935  
F.K.D.®

刃径公差 D ≤ 16 +0.18 ~ +0.30  
 16 < D ≤ 26 +0.21 ~ +0.35  
 26 < D ≤ 45 +0.26 ~ +0.43  
 45 < D ≤ 70 +0.30 ~ +0.50  
 刃幅公差  $\varnothing < 4$  -0.014 ~ -0.028  
 4 ≤  $\varnothing < 7$  -0.020 ~ -0.038  
 7 ≤  $\varnothing \leq 12$  -0.025 ~ -0.047

刃数  
 $\varnothing 6 \sim 13$  8枚  
 $\varnothing 14 \sim 16$  10枚  
 $\varnothing 18 \sim 22$  12枚  
 $\varnothing 24 \sim 32$  14枚  
 $\varnothing 35 \sim 55$  16枚  
 $\varnothing 60 \sim 70$  18枚

材質=HSS

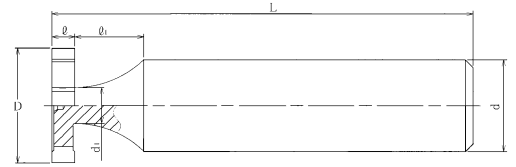
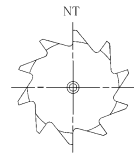

●注文例=型番、刃径、刃幅、数量「KC 40x4」

型番	刃径 (D)	刃幅 (∅)	首径 (d1)	首長 (∅1)	全長 (L)	シャンク径 (d)	標準価格
KC	40	4	10.5	16	70	12	35,100
KC	40	4.5	10.5	16	70	12	35,100
KC	40	5	10.5	16	70	12	35,100
KC	40	5.5	10.5	16	70	12	35,100
KC	40	6	10.5	16	70	12	35,100
KC	40	6.5	10.5	16	70	12	35,100
KC	40	7	10.5	16	70	12	35,100
KC	40	7.5	10.5	16	70	12	35,100
KC	40	8	10.5	16	70	12	35,100
KC	40	8.5	10.5	16	70	12	35,100
KC	40	9	10.5	16	70	12	35,100
KC	40	9.5	10.5	16	70	12	35,100
KC	40	10	10.5	16	70	12	35,100
KC	40	11	10.5	16	70	12	35,100
KC	40	12	10.5	16	70	12	35,100
KC	45	1	11.5	18	80	12	53,500
KC	45	1.1	11.5	18	80	12	53,500
KC	45	1.2	11.5	18	80	12	53,500
KC	45	1.3	11.5	18	80	12	53,500
KC	45	1.4	11.5	18	80	12	53,500
KC	45	1.5	11.5	18	80	12	53,500
KC	45	1.6	11.5	18	80	12	53,500
KC	45	1.7	11.5	18	80	12	53,500
KC	45	1.8	11.5	18	80	12	53,500
KC	45	1.9	11.5	18	80	12	53,500
KC	45	2	11.5	18	80	12	53,500
KC	45	2.1	11.5	18	80	12	53,500
KC	45	2.2	11.5	18	80	12	53,500
KC	45	2.3	11.5	18	80	12	53,500
KC	45	2.4	11.5	18	80	12	53,500
KC	45	2.5	11.5	18	80	12	53,500
KC	45	2.6	11.5	18	80	12	53,500
KC	45	2.7	11.5	18	80	12	53,500
KC	45	2.8	11.5	18	80	12	53,500
KC	45	2.9	11.5	18	80	12	53,500
KC	45	3	11.5	18	80	12	48,800
KC	45	3.5	11.5	18	80	12	48,800
KC	45	4	11.5	18	80	12	48,800
KC	45	4.5	11.5	18	80	12	48,800
KC	45	5	11.5	18	80	12	48,800
KC	45	5.5	11.5	18	80	12	48,800
KC	45	6	11.5	18	80	12	48,800
KC	45	6.5	11.5	18	80	12	48,800
KC	45	7	11.5	18	80	12	48,800

型番	刃径 (D)	刃幅 (∅)	首径 (d1)	首長 (∅1)	全長 (L)	シャンク径 (d)	標準価格
KC	45	7.5	11.5	18	80	12	48,800
KC	45	8	11.5	18	80	12	48,800
KC	45	8.5	11.5	18	80	12	48,800
KC	45	9	11.5	18	80	12	48,800
KC	45	9.5	11.5	18	80	12	48,800
KC	45	10	11.5	18	80	12	48,800
KC	45	12	11.5	18	80	12	48,800
KC	50	1	15	20	80	16	66,100
KC	50	1.5	15	20	80	16	66,100
KC	50	2	15	20	80	16	66,100
KC	50	2.5	15	20	80	16	66,100
KC	50	3	15	20	80	16	60,400
KC	50	3.5	15	20	80	16	60,400
KC	50	4	15	20	80	16	60,400
KC	50	4.5	15	20	80	16	60,400
KC	50	5	15	20	80	16	60,400
KC	50	5.5	15	20	80	16	60,400
KC	50	6	15	20	80	16	60,400
KC	50	6.5	15	20	80	16	60,400
KC	50	7	15	20	80	16	60,400
KC	50	7.5	15	20	80	16	60,400
KC	50	8	15	20	80	16	60,400
KC	50	8.5	15	20	80	16	60,400
KC	50	9	15	20	80	16	60,400
KC	50	9.5	15	20	80	16	60,400
KC	50	10	15	20	80	16	60,400
KC	55	1	15	20	80	20	72,500
KC	55	1.5	15	20	80	20	72,500
KC	55	2	15	20	80	20	72,500
KC	55	2.5	15	20	80	20	72,500
KC	55	3	15	20	80	20	65,900
KC	60	1	16	20	90	20	80,700
KC	60	1.5	16	20	90	20	80,700
KC	60	2	16	20	90	20	80,700
KC	60	2.5	16	20	90	20	80,700
KC	60	3	16	20	90	20	73,400
KC	65	1.5	16	20	90	20	99,300
KC	65	2	16	20	90	20	99,300
KC	65	2.5	16	20	90	20	99,300
KC	65	3	16	20	90	20	90,200
KC	70	1.5	16	20	100	20	109,700
KC	70	2	16	20	100	20	109,700
KC	70	2.5	16	20	100	20	109,700
KC	70	3	16	20	100	20	99,700

# (KCST) 側刃付キーシートカッター

SINCE 1935  
F.K.D.®

刃径公差 D ≤ 16 +0.18 ~ +0.30  
16 < D ≤ 26 +0.21 ~ +0.35  
26 < D ≤ 40 +0.26 ~ +0.43

刃幅公差 = -0.014 ~ -0.028

材質 = HSS

刃数  
φ 8 ~ 12 8枚  
φ 14 ~ 16 10枚  
φ 18 ~ 22 12枚  
φ 25 ~ 30 14枚  
φ 35 ~ 40 16枚

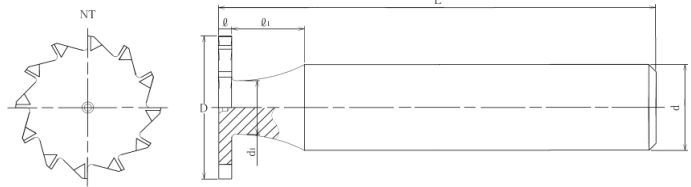

●注文例 = 型番、刃径、刃幅、数量 「KCST 8x1.0」

型番	刃径 (D)	刃幅 (ℓ)	首径 (d1)	首長 (ℓ1)	全長 (L)	シャンク径 (d)	標準価格
KCST	8	1	3.5	6	50	8	10,700
KCST	8	1.2	3.5	6	50	8	10,700
KCST	8	1.5	3.5	6	50	8	10,700
KCST	8	1.6	3.5	6	50	8	10,700
KCST	8	1.8	3.5	6	50	8	10,700
KCST	10	1	4.2	7	50	8	10,700
KCST	10	1.2	4.2	7	50	8	10,700
KCST	10	1.5	4.2	7	50	8	10,700
KCST	10	1.6	4.2	7	50	8	10,700
KCST	10	1.8	4.2	7	50	8	10,700
KCST	12	1	4.4	8	50	10	10,700
KCST	12	1.2	4.4	8	50	10	10,700
KCST	12	1.5	4.4	8	50	10	10,700
KCST	12	1.6	4.4	8	50	10	10,700
KCST	12	1.8	4.4	8	50	10	10,700
KCST	14	1	4.5	8.5	55	10	11,600
KCST	14	1.2	4.5	8.5	55	10	11,600
KCST	14	1.5	4.5	8.5	55	10	11,600
KCST	15	1	4.7	9	55	12	11,600
KCST	15	1.2	4.7	9	55	12	11,600
KCST	15	1.5	4.7	9	55	12	11,600
KCST	15	1.6	4.7	9	55	12	11,600
KCST	15	1.8	4.7	9	55	12	11,600
KCST	16	1	5	9	55	12	12,800
KCST	16	1.2	5	9	55	12	12,800
KCST	16	1.5	5	9	55	12	12,800
KCST	16	1.6	5	9	55	12	12,800
KCST	16	1.8	5	9	55	12	12,800
KCST	18	1	7	9.5	55	12	14,400
KCST	18	1.2	7	9.5	55	12	14,400
KCST	18	1.5	7	9.5	55	12	14,400
KCST	18	1.6	7	9.5	55	12	14,400
KCST	18	1.8	7	9.5	55	12	14,400
KCST	20	1	7.5	10	60	12	16,000
KCST	20	1.2	7.5	10	60	12	16,000
KCST	20	1.5	7.5	10	60	12	16,000
KCST	20	1.6	7.5	10	60	12	16,000
KCST	20	1.8	7.5	10	60	12	16,000

型番	刃径 (D)	刃幅 (ℓ)	首径 (d1)	首長 (ℓ1)	全長 (L)	シャンク径 (d)	標準価格
KCST	22	1	8	10	60	12	18,000
KCST	22	1.2	8	10	60	12	18,000
KCST	22	1.5	8	10	60	12	18,000
KCST	22	1.6	8	10	60	12	18,000
KCST	22	1.8	8	10	60	12	18,000
KCST	25	1	9	12	60	12	20,800
KCST	25	1.2	9	12	60	12	20,800
KCST	25	1.5	9	12	60	12	20,800
KCST	25	1.6	9	12	60	12	20,800
KCST	25	1.8	9	12	60	12	20,800
KCST	26	1	9	12	60	12	22,000
KCST	26	1.2	9	12	60	12	22,000
KCST	26	1.5	9	12	60	12	22,000
KCST	26	1.6	9	12	60	12	22,000
KCST	26	1.8	9	12	60	12	22,000
KCST	28	1	10	12	65	12	25,100
KCST	28	1.2	10	12	65	12	25,100
KCST	28	1.5	10	12	65	12	25,100
KCST	28	1.6	10	12	65	12	25,100
KCST	28	1.8	10	12	65	12	25,100
KCST	30	1	10	12	65	12	28,800
KCST	30	1.2	10	12	65	12	28,800
KCST	30	1.5	10	12	65	12	28,800
KCST	30	1.6	10	12	65	12	28,800
KCST	30	1.8	10	12	65	12	28,800
KCST	35	1	10	15	70	12	37,000
KCST	35	1.2	10	15	70	12	37,000
KCST	35	1.5	10	15	70	12	37,000
KCST	35	1.6	10	15	70	12	37,000
KCST	35	1.8	10	15	70	12	37,000
KCST	40	1	10.5	16	70	12	50,500
KCST	40	1.2	10.5	16	70	12	50,500
KCST	40	1.5	10.5	16	70	12	50,500
KCST	40	1.6	10.5	16	70	12	50,500
KCST	40	1.8	10.5	16	70	12	50,500

(TC)  
Tスロットカッター  
T-Slot Cutters, Straight Tooth

SINCE 1935  
F.K.D.®

刃径公差  
 $D \leq 16$  -0.050~-0.160  
 $16 < D \leq 30$  -0.065~-0.195  
 $30 < D \leq 45$  -0.080~-0.240  
 $45 < D \leq 100$  -0.100~-0.290

刃数  
 $\phi 8 \sim 9$  6枚  $\phi 60 \sim 75$  16枚  
 $\phi 10 \sim 19$  8枚  $\phi 80$  20枚  
 $\phi 20 \sim 26$  10枚  $\phi 90$  22枚  
 $\phi 28 \sim 40$  12枚  $\phi 100$  26枚  
 $\phi 42 \sim 55$  14枚

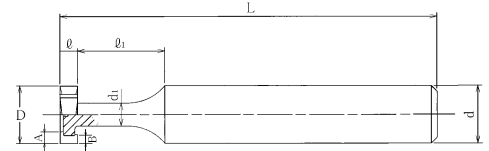
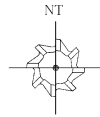

刃幅公差=0~+0.1  
 材質=HSS

●注文例=型番、刃径、刃幅、数量「TC 8x2」 ※両サイド刃の長さはP94に掲載。

型番	刃径 (D)	刃幅 (ℓ)	首径 (d1)	首長 (ℓ1)	全長 (L)	シャンク径 (d)	標準価格
TC	8	2	3.5	15	65	10	11,700
TC	8	2.5	3.5	15	65	10	11,700
TC	8	3	3.5	15	65	10	10,900
TC	8	3.5	3.5	15	65	10	10,900
TC	8	4	3.5	15	65	10	10,900
TC	8	4.5	3.5	15	65	10	10,900
TC	8	5	3.5	15	65	10	10,900
TC	8	5.5	3.5	15	65	10	10,900
TC	8	6	3.5	15	65	10	10,900
TC	8	7	3.5	15	65	10	10,900
TC	8	8	3.5	15	65	10	10,900
TC	9	2	3.5	15	65	10	11,700
TC	9	2.5	3.5	15	65	10	11,700
TC	9	3	3.5	15	65	10	10,900
TC	9	3.5	3.5	15	65	10	10,900
TC	9	4	3.5	15	65	10	10,900
TC	9	4.5	3.5	15	65	10	10,900
TC	9	5	3.5	15	65	10	10,900
TC	9	5.5	3.5	15	65	10	10,900
TC	9	6	3.5	15	65	10	10,900
TC	9	7	3.5	15	65	10	10,900
TC	9	8	3.5	15	65	10	10,900
TC	10	2	4	15	65	10	11,700
TC	10	2.5	4	15	65	10	11,700
TC	10	3	4	15	65	10	10,900
TC	10	3.5	4	15	65	10	10,900
TC	10	4	4	15	65	10	10,900
TC	10	4.5	4	15	65	10	10,900
TC	10	5	4	15	65	10	10,900
TC	10	5.5	4	15	65	10	10,900
TC	10	6	4	15	65	10	10,900
TC	10	7	4	15	65	10	10,900
TC	10	8	4	15	65	10	10,900
TC	10	9	4	15	65	10	10,900
TC	10	10	4	15	65	10	10,900
TC	12	2	5	15	65	10	11,700
TC	12	2.5	5	15	65	10	11,700
TC	12	3	5	15	65	10	10,900
TC	12	3.5	5	15	65	10	10,900
TC	12	4	5	15	65	10	10,900
TC	12	4.5	5	15	65	10	10,900
TC	12	5	5	15	65	10	10,900
TC	12	5.5	5	15	65	10	10,900
TC	12	6	5	15	65	10	10,900
TC	12	7	5	15	65	10	10,900
TC	12	8	5	15	65	10	10,900

型番	刃径 (D)	刃幅 (ℓ)	首径 (d1)	首長 (ℓ1)	全長 (L)	シャンク径 (d)	標準価格
TC	12	9	5	15	65	10	10,900
TC	12	10	5	15	65	10	10,900
TC	13	2	6	18	75	10	11,700
TC	13	2.5	6	18	75	10	11,700
TC	13	3	6	18	75	10	10,900
TC	13	3.5	6	18	75	10	10,900
TC	13	4	6	18	75	10	10,900
TC	13	4.5	6	18	75	10	10,900
TC	13	5	6	18	75	10	10,900
TC	13	5.5	6	18	75	10	10,900
TC	13	6	6	18	75	10	10,900
TC	13	7	6	18	75	10	10,900
TC	13	8	6	18	75	10	10,900
TC	13	9	6	18	75	10	10,900
TC	13	10	6	18	75	10	10,900
TC	14	2	6	20	75	12	11,700
TC	14	2.5	6	20	75	12	11,700
TC	14	3	6	20	75	12	10,900
TC	14	3.5	6	20	75	12	10,900
TC	14	4	6	20	75	12	10,900
TC	14	4.5	6	20	75	12	10,900
TC	14	5	6	20	75	12	10,900
TC	14	5.5	6	20	75	12	10,900
TC	14	6	6	20	75	12	10,900
TC	14	7	6	20	75	12	10,900
TC	14	8	6	20	75	12	10,900
TC	14	9	6	20	75	12	10,900
TC	14	10	6	20	75	12	10,900
TC	15	2	6	20	80	12	12,800
TC	15	2.5	6	20	80	12	12,800
TC	15	3	6	20	80	12	11,700
TC	15	3.5	6	20	80	12	11,700
TC	15	4	6	20	80	12	11,700
TC	15	4.5	6	20	80	12	11,700
TC	15	5	6	20	80	12	11,700
TC	15	5.5	6	20	80	12	11,700
TC	15	6	6	20	80	12	11,700
TC	15	7	6	20	80	12	11,700
TC	15	8	6	20	80	12	11,700
TC	15	9	6	20	80	12	11,700
TC	15	10	6	20	80	12	11,700
TC	15	11	6	20	80	12	12,300
TC	15	12	6	20	80	12	12,300
TC	16	2	7	20	80	12	13,600
TC	16	2.5	7	20	80	12	13,600
TC	16	3	7	20	80	12	12,300

(TC)  
Tスロットカッター  
T-Slot Cutters, Straight Tooth

SINCE 1935  
F.K.D.®

刃径公差  
 $D \leq 16$  -0.050~-0.160  
 $16 < D \leq 30$  -0.065~-0.195  
 $30 < D \leq 45$  -0.080~-0.240  
 $45 < D \leq 100$  -0.100~-0.290

刃数  
 $\phi 8 \sim 9$  6枚  $\phi 60 \sim 75$  16枚  
 $\phi 10 \sim 19$  8枚  $\phi 80$  20枚  
 $\phi 20 \sim 26$  10枚  $\phi 90$  22枚  
 $\phi 28 \sim 40$  12枚  $\phi 100$  26枚  
 $\phi 42 \sim 55$  14枚

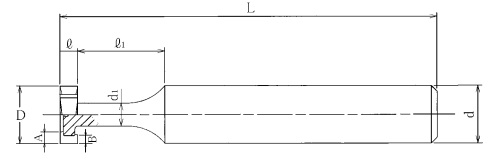
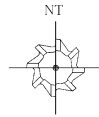

刃幅公差=0~+0.1  
 材質=HSS

●注文例=型番、刃径、刃幅、数量「TC 16x3.5」 ※両サイド刃の長さはP94に掲載。

型番	刃径 (D)	刃幅 (ℓ)	首径 (d1)	首長 (ℓ1)	全長 (L)	シャンク径 (d)	標準価格
TC	16	3.5	7	20	80	12	12,300
TC	16	4	7	20	80	12	12,300
TC	16	4.5	7	20	80	12	12,300
TC	16	5	7	20	80	12	12,300
TC	16	5.5	7	20	80	12	12,300
TC	16	6	7	20	80	12	12,300
TC	16	7	7	20	80	12	12,300
TC	16	8	7	20	80	12	12,300
TC	16	9	7	20	80	12	12,300
TC	16	10	7	20	80	12	12,300
TC	16	11	7	20	80	12	12,700
TC	16	12	7	20	80	12	12,700
TC	16	13	7	20	80	12	12,700
TC	16	14	7	20	80	12	12,700
TC	16	15	7	20	80	12	12,700
TC	16	16	7	20	80	12	12,700
TC	18	2	8.5	20	80	12	15,000
TC	18	2.5	8.5	20	80	12	15,000
TC	18	3	8.5	20	80	12	13,600
TC	18	3.5	8.5	20	80	12	13,600
TC	18	4	8.5	20	80	12	13,600
TC	18	4.5	8.5	20	80	12	13,600
TC	18	5	8.5	20	80	12	13,600
TC	18	5.5	8.5	20	80	12	13,600
TC	18	6	8.5	20	80	12	13,600
TC	18	7	8.5	20	80	12	13,600
TC	18	8	8.5	20	80	12	13,600
TC	18	9	8.5	20	80	12	13,600
TC	18	10	8.5	20	80	12	13,600
TC	18	11	8.5	20	80	12	14,300
TC	18	12	8.5	20	80	12	14,300
TC	18	13	8.5	20	80	12	14,300
TC	18	14	8.5	20	80	12	14,300
TC	18	15	8.5	20	80	12	14,300
TC	18	16	8.5	20	80	12	14,300
TC	19	2	8.5	20	80	12	15,700
TC	19	2.5	8.5	20	80	12	15,700
TC	19	3	8.5	20	80	12	14,300
TC	19	3.5	8.5	20	80	12	14,300
TC	19	4	8.5	20	80	12	14,300
TC	19	4.5	8.5	20	80	12	14,300
TC	19	5	8.5	20	80	12	14,300
TC	19	5.5	8.5	20	80	12	14,300
TC	19	6	8.5	20	80	12	14,300
TC	19	7	8.5	20	80	12	14,300
TC	19	8	8.5	20	80	12	14,300

型番	刃径 (D)	刃幅 (ℓ)	首径 (d1)	首長 (ℓ1)	全長 (L)	シャンク径 (d)	標準価格
TC	19	9	8.5	20	80	12	14,300
TC	19	10	8.5	20	80	12	14,300
TC	19	11	8.5	20	80	12	15,000
TC	19	12	8.5	20	80	12	15,000
TC	19	13	8.5	20	80	12	15,000
TC	19	14	8.5	20	80	12	15,000
TC	19	15	8.5	20	80	12	15,000
TC	19	16	8.5	20	80	12	15,000
TC	20	2	9	22	90	12	16,600
TC	20	2.5	9	22	90	12	16,600
TC	20	3	9	22	90	12	15,400
TC	20	3.5	9	22	90	12	15,400
TC	20	4	9	22	90	12	15,400
TC	20	4.5	9	22	90	12	15,400
TC	20	5	9	22	90	12	15,400
TC	20	5.5	9	22	90	12	15,400
TC	20	6	9	22	90	12	15,400
TC	20	7	9	22	90	12	15,400
TC	20	8	9	22	90	12	15,400
TC	20	9	9	22	90	12	15,400
TC	20	10	9	22	90	12	15,400
TC	20	11	9	22	90	12	16,200
TC	20	12	9	22	90	12	16,200
TC	20	13	9	22	90	12	16,200
TC	20	14	9	22	90	12	16,200
TC	20	15	9	22	90	12	16,200
TC	20	16	9	22	90	12	16,200
TC	22	2	9.5	22	90	12	17,800
TC	22	2.5	9.5	22	90	12	17,800
TC	22	3	9.5	22	90	12	16,300
TC	22	3.5	9.5	22	90	12	16,300
TC	22	4	9.5	22	90	12	16,300
TC	22	4.5	9.5	22	90	12	16,300
TC	22	5	9.5	22	90	12	16,300
TC	22	5.5	9.5	22	90	12	16,300
TC	22	6	9.5	22	90	12	16,300
TC	22	7	9.5	22	90	12	16,300
TC	22	8	9.5	22	90	12	16,300
TC	22	9	9.5	22	90	12	16,300
TC	22	10	9.5	22	90	12	16,300
TC	22	11	9.5	22	90	12	17,400
TC	22	12	9.5	22	90	12	17,400
TC	22	13	9.5	22	90	12	17,400
TC	22	14	9.5	22	90	12	17,400
TC	22	15	9.5	22	90	12	17,400
TC	22	16	9.5	22	90	12	17,400

(TC)  
Tスロットカッター  
T-Slot Cutters, Straight Tooth

SINCE 1935  
F.K.D.®

刃径公差  
 $D \leq 16$  -0.050~-0.160  
 $16 < D \leq 30$  -0.065~-0.195  
 $30 < D \leq 45$  -0.080~-0.240  
 $45 < D \leq 100$  -0.100~-0.290

刃数  
 $\phi 8 \sim 9$  6枚  $\phi 60 \sim 75$  16枚  
 $\phi 10 \sim 19$  8枚  $\phi 80$  20枚  
 $\phi 20 \sim 26$  10枚  $\phi 90$  22枚  
 $\phi 28 \sim 40$  12枚  $\phi 100$  26枚  
 $\phi 42 \sim 55$  14枚

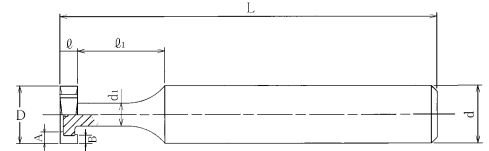
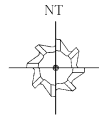

刃幅公差=0~+0.1  
 材質=HSS

●注文例=型番、刃径、刃幅、数量「TC 24x2」 ※両サイド刃の長さはP94に掲載。

型番	刃径 (D)	刃幅 (l)	首径 (d1)	首長 (l1)	全長 (L)	シャンク径 (d)	標準価格
TC	24	2	11	24	100	12	21,900
TC	24	2.5	11	24	100	12	21,900
TC	24	3	11	24	100	12	20,000
TC	24	3.5	11	24	100	12	20,000
TC	24	4	11	24	100	12	20,000
TC	24	4.5	11	24	100	12	20,000
TC	24	5	11	24	100	12	20,000
TC	24	5.5	11	24	100	12	20,000
TC	24	6	11	24	100	12	20,000
TC	24	7	11	24	100	12	20,000
TC	24	8	11	24	100	12	20,000
TC	24	9	11	24	100	12	20,000
TC	24	10	11	24	100	12	20,000
TC	24	11	11	24	100	12	21,100
TC	24	12	11	24	100	12	21,100
TC	24	13	11	24	100	12	21,100
TC	24	14	11	24	100	12	21,100
TC	24	15	11	24	100	12	21,100
TC	24	16	11	24	100	12	21,100
TC	25	2	11	24	100	12	21,900
TC	25	2.5	11	24	100	12	21,900
TC	25	3	11	24	100	12	20,000
TC	25	3.5	11	24	100	12	20,000
TC	25	4	11	24	100	12	20,000
TC	25	4.5	11	24	100	12	20,000
TC	25	5	11	24	100	12	20,000
TC	25	5.5	11	24	100	12	20,000
TC	25	6	11	24	100	12	20,000
TC	25	7	11	24	100	12	20,000
TC	25	8	11	24	100	12	20,000
TC	25	9	11	24	100	12	20,000
TC	25	10	11	24	100	12	20,000
TC	25	11	11	24	100	12	21,100
TC	25	12	11	24	100	12	21,100
TC	25	13	11	24	100	12	21,100
TC	25	14	11	24	100	12	21,100
TC	25	15	11	24	100	12	21,100
TC	25	16	11	24	100	12	21,100
TC	25	18	11	24	100	12	21,100
TC	25	20	11	24	100	12	21,100
TC	26	2	11	24	100	12	21,900
TC	26	2.5	11	24	100	12	21,900
TC	26	3	11	24	100	12	20,000
TC	26	3.5	11	24	100	12	20,000
TC	26	4	11	24	100	12	20,000
TC	26	4.5	11	24	100	12	20,000

型番	刃径 (D)	刃幅 (l)	首径 (d1)	首長 (l1)	全長 (L)	シャンク径 (d)	標準価格
TC	26	5	11	24	100	12	20,000
TC	26	5.5	11	24	100	12	20,000
TC	26	6	11	24	100	12	20,000
TC	26	7	11	24	100	12	20,000
TC	26	8	11	24	100	12	20,000
TC	26	9	11	24	100	12	20,000
TC	26	10	11	24	100	12	20,000
TC	26	11	11	24	100	12	21,100
TC	26	12	11	24	100	12	21,100
TC	26	13	11	24	100	12	21,100
TC	26	14	11	24	100	12	21,100
TC	26	15	11	24	100	12	21,100
TC	26	16	11	24	100	12	21,100
TC	26	18	11	24	100	12	21,100
TC	26	20	11	24	100	12	21,100
TC	28	2	11	24	100	12	23,500
TC	28	2.5	11	24	100	12	23,500
TC	28	3	11	24	100	12	21,300
TC	28	3.5	11	24	100	12	21,300
TC	28	4	11	24	100	12	21,300
TC	28	4.5	11	24	100	12	21,300
TC	28	5	11	24	100	12	21,300
TC	28	5.5	11	24	100	12	21,300
TC	28	6	11	24	100	12	21,300
TC	28	7	11	24	100	12	21,300
TC	28	8	11	24	100	12	21,300
TC	28	9	11	24	100	12	21,300
TC	28	10	11	24	100	12	21,300
TC	28	11	11	24	100	12	22,400
TC	28	12	11	24	100	12	22,400
TC	28	13	11	24	100	12	22,400
TC	28	14	11	24	100	12	22,400
TC	28	15	11	24	100	12	22,400
TC	28	16	11	24	100	12	22,400
TC	28	18	11	24	100	12	22,400
TC	28	20	11	24	100	12	22,400
TC	30	2	13	24	100	16	27,100
TC	30	2.5	13	24	100	16	27,100
TC	30	3	13	24	100	16	24,800
TC	30	3.5	13	24	100	16	24,800
TC	30	4	13	24	100	16	24,800
TC	30	4.5	13	24	100	16	24,800
TC	30	5	13	24	100	16	24,800
TC	30	5.5	13	24	100	16	24,800
TC	30	6	13	24	100	16	24,800
TC	30	7	13	24	100	16	24,800

(TC)  
Tスロットカッター  
T-Slot Cutters, Straight Tooth

SINCE 1935  
F.K.D.®

刃径公差  
 $D \leq 16$  -0.050~-0.160  
 $16 < D \leq 30$  -0.065~-0.195  
 $30 < D \leq 45$  -0.080~-0.240  
 $45 < D \leq 100$  -0.100~-0.290

刃数  
 $\phi 8 \sim 9$  6枚  $\phi 60 \sim 75$  16枚  
 $\phi 10 \sim 19$  8枚  $\phi 80$  20枚  
 $\phi 20 \sim 26$  10枚  $\phi 90$  22枚  
 $\phi 28 \sim 40$  12枚  $\phi 100$  26枚  
 $\phi 42 \sim 55$  14枚

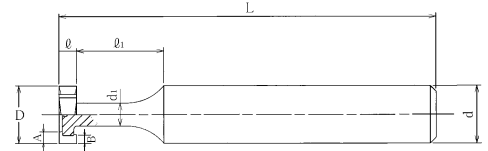
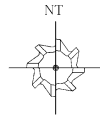

刃幅公差=0~+0.1  
 材質=HSS

●注文例=型番、刃径、刃幅、数量「TC 30x8」 ※両サイド刃の長さはP94に掲載。

型番	刃径 (D)	刃幅 (ℓ)	首径 (d1)	首長 (ℓ1)	全長 (L)	シャンク径 (d)	標準価格
TC	30	8	13	24	100	16	24,800
TC	30	9	13	24	100	16	24,800
TC	30	10	13	24	100	16	24,800
TC	30	11	13	24	100	16	25,900
TC	30	12	13	24	100	16	25,900
TC	30	13	13	24	100	16	25,900
TC	30	14	13	24	100	16	25,900
TC	30	15	13	24	100	16	25,900
TC	30	16	13	24	100	16	25,900
TC	30	17	13	24	100	16	25,900
TC	30	18	13	24	100	16	25,900
TC	30	19	13	24	100	16	25,900
TC	30	20	13	24	100	16	25,900
TC	32	2	13	24	105	16	30,400
TC	32	2.5	13	24	105	16	30,400
TC	32	3	13	24	105	16	27,800
TC	32	3.5	13	24	105	16	27,800
TC	32	4	13	24	105	16	27,800
TC	32	4.5	13	24	105	16	27,800
TC	32	5	13	24	105	16	27,800
TC	32	5.5	13	24	105	16	27,800
TC	32	6	13	24	105	16	27,800
TC	32	7	13	24	105	16	27,800
TC	32	8	13	24	105	16	27,800
TC	32	9	13	24	105	16	27,800
TC	32	10	13	24	105	16	27,800
TC	32	11	13	24	105	16	29,200
TC	32	12	13	24	105	16	29,200
TC	32	13	13	24	105	16	29,200
TC	32	14	13	24	105	16	29,200
TC	32	15	13	24	105	16	29,200
TC	32	16	13	24	105	16	29,200
TC	32	17	13	24	105	16	29,200
TC	32	18	13	24	105	16	29,200
TC	32	19	13	24	105	16	29,200
TC	32	20	13	24	105	16	29,200
TC	35	2	14	24	105	16	33,200
TC	35	2.5	14	24	105	16	33,200
TC	35	3	14	24	105	16	30,400
TC	35	3.5	14	24	105	16	30,400
TC	35	4	14	24	105	16	30,400
TC	35	4.5	14	24	105	16	30,400
TC	35	5	14	24	105	16	30,400
TC	35	5.5	14	24	105	16	30,400
TC	35	6	14	24	105	16	30,400
TC	35	7	14	24	105	16	30,400

型番	刃径 (D)	刃幅 (ℓ)	首径 (d1)	首長 (ℓ1)	全長 (L)	シャンク径 (d)	標準価格
TC	35	8	14	24	105	16	30,400
TC	35	9	14	24	105	16	30,400
TC	35	10	14	24	105	16	30,400
TC	35	11	14	24	105	16	32,000
TC	35	12	14	24	105	16	32,000
TC	35	13	14	24	105	16	32,000
TC	35	14	14	24	105	16	32,000
TC	35	15	14	24	105	16	32,000
TC	35	16	14	24	105	16	32,000
TC	35	17	14	24	105	16	32,000
TC	35	18	14	24	105	16	32,000
TC	35	19	14	24	105	16	32,000
TC	35	20	14	24	105	16	32,000
TC	36	2	14	24	105	16	38,100
TC	36	2.5	14	24	105	16	38,100
TC	36	3	14	24	105	16	34,500
TC	36	3.5	14	24	105	16	34,500
TC	36	4	14	24	105	16	34,500
TC	36	4.5	14	24	105	16	34,500
TC	36	5	14	24	105	16	34,500
TC	36	5.5	14	24	105	16	34,500
TC	36	6	14	24	105	16	34,500
TC	36	7	14	24	105	16	34,500
TC	36	8	14	24	105	16	34,500
TC	36	9	14	24	105	16	34,500
TC	36	10	14	24	105	16	34,500
TC	36	11	14	24	105	16	36,400
TC	36	12	14	24	105	16	36,400
TC	36	13	14	24	105	16	36,400
TC	36	14	14	24	105	16	36,400
TC	36	15	14	24	105	16	36,400
TC	36	16	14	24	105	16	36,400
TC	36	17	14	24	105	16	36,400
TC	36	18	14	24	105	16	36,400
TC	36	19	14	24	105	16	36,400
TC	36	20	14	24	105	16	36,400
TC	38	2	14	24	105	16	42,900
TC	38	2.5	14	24	105	16	42,900
TC	38	3	14	24	105	16	38,900
TC	38	3.5	14	24	105	16	38,900
TC	38	4	14	24	105	16	38,900
TC	38	4.5	14	24	105	16	38,900
TC	38	5	14	24	105	16	38,900
TC	38	5.5	14	24	105	16	38,900
TC	38	6	14	24	105	16	38,900
TC	38	7	14	24	105	16	38,900

(TC)  
Tスロットカッター  
T-Slot Cutters, Straight Tooth

SINCE 1935  
F.K.D.®

刃径公差  
 $D \leq 16$  -0.050~-0.160  
 $16 < D \leq 30$  -0.065~-0.195  
 $30 < D \leq 45$  -0.080~-0.240  
 $45 < D \leq 100$  -0.100~-0.290

刃数  
 $\phi 8 \sim 9$  6枚  $\phi 60 \sim 75$  16枚  
 $\phi 10 \sim 19$  8枚  $\phi 80$  20枚  
 $\phi 20 \sim 26$  10枚  $\phi 90$  22枚  
 $\phi 28 \sim 40$  12枚  $\phi 100$  26枚  
 $\phi 42 \sim 55$  14枚

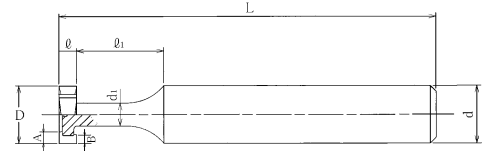
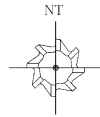

刃幅公差=0~+0.1  
 材質=HSS

●注文例=型番、刃径、刃幅、数量「TC 38x8」 ※両サイド刃の長さはP94に掲載。

型番	刃径 (D)	刃幅 (ℓ)	首径 (d1)	首長 (ℓ1)	全長 (L)	シャンク径 (d)	標準価格
TC	38	8	14	24	105	16	38,900
TC	38	9	14	24	105	16	38,900
TC	38	10	14	24	105	16	38,900
TC	38	11	14	24	105	16	40,800
TC	38	12	14	24	105	16	40,800
TC	38	13	14	24	105	16	40,800
TC	38	14	14	24	105	16	40,800
TC	38	15	14	24	105	16	40,800
TC	38	16	14	24	105	16	40,800
TC	38	17	14	24	105	16	40,800
TC	38	18	14	24	105	16	40,800
TC	38	19	14	24	105	16	40,800
TC	38	20	14	24	105	16	40,800
TC	40	2	15	24	110	16	44,400
TC	40	2.5	15	24	110	16	44,400
TC	40	3	15	24	110	16	40,400
TC	40	3.5	15	24	110	16	40,400
TC	40	4	15	24	110	16	40,400
TC	40	4.5	15	24	110	16	40,400
TC	40	5	15	24	110	16	40,400
TC	40	5.5	15	24	110	16	40,400
TC	40	6	15	24	110	16	40,400
TC	40	7	15	24	110	16	40,400
TC	40	8	15	24	110	16	40,400
TC	40	9	15	24	110	16	40,400
TC	40	10	15	24	110	16	40,400
TC	40	11	15	24	110	16	42,500
TC	40	12	15	24	110	16	42,500
TC	40	13	15	24	110	16	42,500
TC	40	14	15	24	110	16	42,500
TC	40	15	15	24	110	16	42,500
TC	40	16	15	24	110	16	42,500
TC	40	17	15	24	110	16	42,500
TC	40	18	15	24	110	16	42,500
TC	40	19	15	24	110	16	42,500
TC	40	20	15	24	110	16	42,500
TC	40	22	15	24	110	16	44,400
TC	40	24	15	24	110	16	44,400
TC	40	25	15	24	110	16	44,400
TC	40	26	15	24	110	16	44,400
TC	40	28	15	24	110	16	44,400
TC	40	30	15	24	110	16	44,400
TC	42	2	15	24	110	16	50,600
TC	42	2.5	15	24	110	16	50,600
TC	42	3	15	24	110	16	45,900
TC	42	3.5	15	24	110	16	45,900

型番	刃径 (D)	刃幅 (ℓ)	首径 (d1)	首長 (ℓ1)	全長 (L)	シャンク径 (d)	標準価格
TC	42	4	15	24	110	16	45,900
TC	42	4.5	15	24	110	16	45,900
TC	42	5	15	24	110	16	45,900
TC	42	5.5	15	24	110	16	45,900
TC	42	6	15	24	110	16	45,900
TC	42	7	15	24	110	16	45,900
TC	42	8	15	24	110	16	45,900
TC	42	9	15	24	110	16	45,900
TC	42	10	15	24	110	16	45,900
TC	42	11	15	24	110	16	48,400
TC	42	12	15	24	110	16	48,400
TC	42	13	15	24	110	16	48,400
TC	42	14	15	24	110	16	48,400
TC	42	15	15	24	110	16	48,400
TC	42	16	15	24	110	16	48,400
TC	42	17	15	24	110	16	48,400
TC	42	18	15	24	110	16	48,400
TC	42	19	15	24	110	16	48,400
TC	42	20	15	24	110	16	48,400
TC	42	22	15	24	110	16	50,600
TC	42	24	15	24	110	16	50,600
TC	42	25	15	24	110	16	50,600
TC	42	26	15	24	110	16	50,600
TC	42	28	15	24	110	16	50,600
TC	42	30	15	24	110	16	50,600
TC	45	2	15	24	110	16	57,100
TC	45	2.5	15	24	110	16	57,100
TC	45	3	15	24	110	16	51,600
TC	45	3.5	15	24	110	16	51,600
TC	45	4	15	24	110	16	51,600
TC	45	4.5	15	24	110	16	51,600
TC	45	5	15	24	110	16	51,600
TC	45	5.5	15	24	110	16	51,600
TC	45	6	15	24	110	16	51,600
TC	45	7	15	24	110	16	51,600
TC	45	8	15	24	110	16	51,600
TC	45	9	15	24	110	16	51,600
TC	45	10	15	24	110	16	51,600
TC	45	11	15	24	110	16	54,500
TC	45	12	15	24	110	16	54,500
TC	45	13	15	24	110	16	54,500
TC	45	14	15	24	110	16	54,500
TC	45	15	15	24	110	16	54,500
TC	45	16	15	24	110	16	54,500
TC	45	17	15	24	110	16	54,500
TC	45	18	15	24	110	16	54,500

(TC)  
Tスロットカッター  
T-Slot Cutters, Straight Tooth

SINCE 1935  
F.K.D.®

刃径公差  
 $D \leq 16$  -0.050~-0.160  
 $16 < D \leq 30$  -0.065~-0.195  
 $30 < D \leq 45$  -0.080~-0.240  
 $45 < D \leq 100$  -0.100~-0.290

刃数  
 $\phi 8 \sim 9$  6枚  $\phi 60 \sim 75$  16枚  
 $\phi 10 \sim 19$  8枚  $\phi 80$  20枚  
 $\phi 20 \sim 26$  10枚  $\phi 90$  22枚  
 $\phi 28 \sim 40$  12枚  $\phi 100$  26枚  
 $\phi 42 \sim 55$  14枚

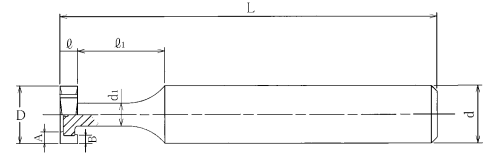
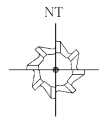

刃幅公差=0~+0.1  
 材質=HSS

●注文例=型番、刃径、刃幅、数量「TC 45x19」 ※両サイド刃の長さはP94に掲載。

型番	刃径 (D)	刃幅 (ℓ)	首径 (d1)	首長 (ℓ1)	全長 (L)	シャンク径 (d)	標準価格
TC	45	19	15	24	110	16	54,500
TC	45	20	15	24	110	16	54,500
TC	45	22	15	24	110	16	57,100
TC	45	24	15	24	110	16	57,100
TC	45	25	15	24	110	16	57,100
TC	45	26	15	24	110	16	57,100
TC	45	28	15	24	110	16	57,100
TC	45	30	15	24	110	16	57,100
TC	48	2	18	30	110	20	62,300
TC	48	2.5	18	30	110	20	62,300
TC	48	3	18	30	110	20	56,500
TC	48	3.5	18	30	110	20	56,500
TC	48	4	18	30	110	20	56,500
TC	48	4.5	18	30	110	20	56,500
TC	48	5	18	30	110	20	56,500
TC	48	5.5	18	30	110	20	56,500
TC	48	6	18	30	110	20	56,500
TC	48	7	18	30	110	20	56,500
TC	48	8	18	30	110	20	56,500
TC	48	9	18	30	110	20	56,500
TC	48	10	18	30	110	20	56,500
TC	48	11	18	30	110	20	59,300
TC	48	12	18	30	110	20	59,300
TC	48	13	18	30	110	20	59,300
TC	48	14	18	30	110	20	59,300
TC	48	15	18	30	110	20	59,300
TC	48	16	18	30	110	20	59,300
TC	48	17	18	30	110	20	59,300
TC	48	18	18	30	110	20	59,300
TC	48	19	18	30	110	20	59,300
TC	48	20	18	30	110	20	59,300
TC	48	22	18	30	110	20	62,300
TC	48	24	18	30	110	20	62,300
TC	48	25	18	30	110	20	62,300
TC	48	26	18	30	110	20	62,300
TC	48	28	18	30	110	20	62,300
TC	48	30	18	30	110	20	62,300
TC	50	2	18	30	130	20	67,500
TC	50	2.5	18	30	130	20	67,500
TC	50	3	18	30	130	20	61,500
TC	50	3.5	18	30	130	20	61,500
TC	50	4	18	30	130	20	61,500
TC	50	4.5	18	30	130	20	61,500
TC	50	5	18	30	130	20	61,500
TC	50	5.5	18	30	130	20	61,500
TC	50	6	18	30	130	20	61,500

型番	刃径 (D)	刃幅 (ℓ)	首径 (d1)	首長 (ℓ1)	全長 (L)	シャンク径 (d)	標準価格
TC	50	7	18	30	130	20	61,500
TC	50	8	18	30	130	20	61,500
TC	50	9	18	30	130	20	61,500
TC	50	10	18	30	130	20	61,500
TC	50	11	18	30	130	20	64,700
TC	50	12	18	30	130	20	64,700
TC	50	13	18	30	130	20	64,700
TC	50	14	18	30	130	20	64,700
TC	50	15	18	30	130	20	64,700
TC	50	16	18	30	130	20	64,700
TC	50	17	18	30	130	20	64,700
TC	50	18	18	30	130	20	64,700
TC	50	19	18	30	130	20	64,700
TC	50	20	18	30	130	20	64,700
TC	50	22	18	30	130	20	67,500
TC	50	24	18	30	130	20	67,500
TC	50	25	18	30	130	20	67,500
TC	50	26	18	30	130	20	67,500
TC	50	28	18	30	130	20	67,500
TC	50	30	18	30	130	20	67,500
TC	55	2	20	40	130	25	87,300
TC	55	2.5	20	40	130	25	87,300
TC	55	3	20	40	130	25	79,400
TC	55	3.5	20	40	130	25	79,400
TC	55	4	20	40	130	25	79,400
TC	55	4.5	20	40	130	25	79,400
TC	55	5	20	40	130	25	79,400
TC	55	5.5	20	40	130	25	79,400
TC	55	6	20	40	130	25	79,400
TC	55	7	20	40	130	25	79,400
TC	55	8	20	40	130	25	79,400
TC	55	9	20	40	130	25	79,400
TC	55	10	20	40	130	25	79,400
TC	55	11	20	40	130	25	83,300
TC	55	12	20	40	130	25	83,300
TC	55	13	20	40	130	25	83,300
TC	55	14	20	40	130	25	83,300
TC	55	15	20	40	130	25	83,300
TC	55	16	20	40	130	25	83,300
TC	55	17	20	40	130	25	83,300
TC	55	18	20	40	130	25	83,300
TC	55	19	20	40	130	25	83,300
TC	55	20	20	40	130	25	83,300
TC	55	22	20	40	130	25	87,300
TC	55	24	20	40	130	25	87,300
TC	55	25	20	40	130	25	87,300



(TC)  
Tスロットカッター  
T-Slot Cutters, Straight Tooth

SINCE 1935  
F.K.D.®

刃径公差  
 $D \leq 16$  -0.050~-0.160  
 $16 < D \leq 30$  -0.065~-0.195  
 $30 < D \leq 45$  -0.080~-0.240  
 $45 < D \leq 100$  -0.100~-0.290

刃数  
 $\phi 8 \sim 9$  6枚  $\phi 60 \sim 75$  16枚  
 $\phi 10 \sim 19$  8枚  $\phi 80$  20枚  
 $\phi 20 \sim 26$  10枚  $\phi 90$  22枚  
 $\phi 28 \sim 40$  12枚  $\phi 100$  26枚  
 $\phi 42 \sim 55$  14枚

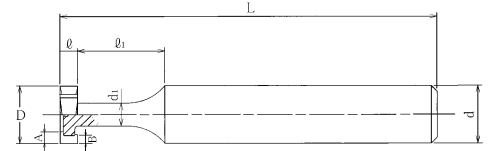
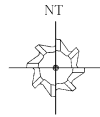

刃幅公差=0~+0.1  
 材質=HSS

●注文例=型番、刃径、刃幅、数量「TC 55x26」 ※両サイド刃の長さはP94に掲載。

型番	刃径 (D)	刃幅 (ℓ)	首径 (d1)	首長 (ℓ1)	全長 (L)	シャンク径 (d)	標準価格
TC	55	26	20	40	130	25	87,300
TC	55	28	20	40	130	25	87,300
TC	55	30	20	40	130	25	87,300
TC	60	2	23	50	170	25	102,200
TC	60	2.5	23	50	170	25	102,200
TC	60	3	23	50	170	25	93,100
TC	60	3.5	23	50	170	25	93,100
TC	60	4	23	50	170	25	93,100
TC	60	4.5	23	50	170	25	93,100
TC	60	5	23	50	170	25	93,100
TC	60	5.5	23	50	170	25	93,100
TC	60	6	23	50	170	25	93,100
TC	60	7	23	50	170	25	93,100
TC	60	8	23	50	170	25	93,100
TC	60	9	23	50	170	25	93,100
TC	60	10	23	50	170	25	93,100
TC	60	11	23	50	170	25	97,700
TC	60	12	23	50	170	25	97,700
TC	60	13	23	50	170	25	97,700
TC	60	14	23	50	170	25	97,700
TC	60	15	23	50	170	25	97,700
TC	60	16	23	50	170	25	97,700
TC	60	17	23	50	170	25	97,700
TC	60	18	23	50	170	25	97,700
TC	60	19	23	50	170	25	97,700
TC	60	20	23	50	170	25	97,700
TC	60	22	23	50	170	25	102,200
TC	60	24	23	50	170	25	102,200
TC	60	25	23	50	170	25	102,200
TC	60	26	23	50	170	25	102,200
TC	60	28	23	50	170	25	102,200
TC	60	30	23	50	170	25	102,200
TC	65	3	23	50	170	25	113,700
TC	65	3.5	23	50	170	25	113,700
TC	65	4	23	50	170	25	113,700
TC	65	4.5	23	50	170	25	113,700
TC	65	5	23	50	170	25	113,700
TC	65	5.5	23	50	170	25	113,700
TC	65	6	23	50	170	25	113,700
TC	65	7	23	50	170	25	113,700
TC	65	8	23	50	170	25	113,700
TC	65	9	23	50	170	25	113,700
TC	65	10	23	50	170	25	113,700
TC	65	11	23	50	170	25	119,600
TC	65	12	23	50	170	25	119,600
TC	65	13	23	50	170	25	119,600

型番	刃径 (D)	刃幅 (ℓ)	首径 (d1)	首長 (ℓ1)	全長 (L)	シャンク径 (d)	標準価格
TC	65	14	23	50	170	25	119,600
TC	65	15	23	50	170	25	119,600
TC	65	16	23	50	170	25	119,600
TC	65	17	23	50	170	25	119,600
TC	65	18	23	50	170	25	119,600
TC	65	19	23	50	170	25	119,600
TC	65	20	23	50	170	25	119,600
TC	65	22	23	50	170	25	125,300
TC	65	24	23	50	170	25	125,300
TC	65	25	23	50	170	25	125,300
TC	65	26	23	50	170	25	125,300
TC	65	28	23	50	170	25	125,300
TC	65	30	23	50	170	25	125,300
TC	70	3	23	50	170	25	123,100
TC	70	3.5	23	50	170	25	123,100
TC	70	4	23	50	170	25	123,100
TC	70	4.5	23	50	170	25	123,100
TC	70	5	23	50	170	25	123,100
TC	70	5.5	23	50	170	25	123,100
TC	70	6	23	50	170	25	123,100
TC	70	7	23	50	170	25	123,100
TC	70	8	23	50	170	25	123,100
TC	70	9	23	50	170	25	123,100
TC	70	10	23	50	170	25	123,100
TC	70	11	23	50	170	25	129,100
TC	70	12	23	50	170	25	129,100
TC	70	13	23	50	170	25	129,100
TC	70	14	23	50	170	25	129,100
TC	70	15	23	50	170	25	129,100
TC	70	16	23	50	170	25	129,100
TC	70	17	23	50	170	25	129,100
TC	70	18	23	50	170	25	129,100
TC	70	19	23	50	170	25	129,100
TC	70	20	23	50	170	25	129,100
TC	70	22	23	50	170	25	135,500
TC	70	24	23	50	170	25	135,500
TC	70	25	23	50	170	25	135,500
TC	70	26	23	50	170	25	135,500
TC	70	28	23	50	170	25	135,500
TC	70	30	23	50	170	25	135,500
TC	75	3	30	50	200	32	137,700
TC	75	3.5	30	50	200	32	137,700
TC	75	4	30	50	200	32	137,700
TC	75	4.5	30	50	200	32	137,700
TC	75	5	30	50	200	32	137,700
TC	75	5.5	30	50	200	32	137,700

(TC)  
Tスロットカッター  
T-Slot Cutters, Straight Tooth

SINCE 1935  
F.K.D.®

刃径公差  
 $D \leq 16$  -0.050~-0.160  
 $16 < D \leq 30$  -0.065~-0.195  
 $30 < D \leq 45$  -0.080~-0.240  
 $45 < D \leq 100$  -0.100~-0.290

刃数  
 $\phi 8 \sim 9$  6枚  $\phi 60 \sim 75$  16枚  
 $\phi 10 \sim 19$  8枚  $\phi 80$  20枚  
 $\phi 20 \sim 26$  10枚  $\phi 90$  22枚  
 $\phi 28 \sim 40$  12枚  $\phi 100$  26枚  
 $\phi 42 \sim 55$  14枚

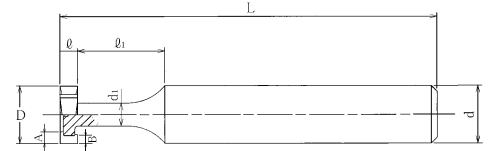
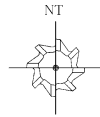

刃幅公差=0~+0.1  
 材質=HSS

●注文例=型番、刃径、刃幅、数量「TC 75x6」 ※両サイド刃の長さはP94に掲載。

型番	刃径 (D)	刃幅 (ℓ)	首径 (d1)	首長 (ℓ1)	全長 (L)	シャンク径 (d)	標準価格
TC	75	6	30	50	200	32	137,700
TC	75	7	30	50	200	32	137,700
TC	75	8	30	50	200	32	137,700
TC	75	9	30	50	200	32	137,700
TC	75	10	30	50	200	32	137,700
TC	75	11	30	50	200	32	144,500
TC	75	12	30	50	200	32	144,500
TC	75	13	30	50	200	32	144,500
TC	75	14	30	50	200	32	144,500
TC	75	15	30	50	200	32	144,500
TC	75	16	30	50	200	32	144,500
TC	75	17	30	50	200	32	144,500
TC	75	18	30	50	200	32	144,500
TC	75	19	30	50	200	32	144,500
TC	75	20	30	50	200	32	144,500
TC	75	22	30	50	200	32	151,700
TC	75	24	30	50	200	32	151,700
TC	75	25	30	50	200	32	151,700
TC	75	26	30	50	200	32	151,700
TC	75	28	30	50	200	32	151,700
TC	75	30	30	50	200	32	151,700
TC	80	3	30	50	210	32	175,700
TC	80	4	30	50	210	32	175,700
TC	80	5	30	50	210	32	175,700
TC	80	6	30	50	210	32	175,700
TC	80	7	30	50	210	32	175,700
TC	80	8	30	50	210	32	175,700
TC	80	9	30	50	210	32	175,700
TC	80	10	30	50	210	32	175,700
TC	80	11	30	50	210	32	184,600
TC	80	12	30	50	210	32	184,600
TC	80	13	30	50	210	32	184,600
TC	80	14	30	50	210	32	184,600
TC	80	15	30	50	210	32	184,600
TC	80	16	30	50	210	32	184,600
TC	80	17	30	50	210	32	184,600
TC	80	18	30	50	210	32	184,600
TC	80	19	30	50	210	32	184,600
TC	80	20	30	50	210	32	184,600
TC	80	22	30	50	210	32	193,300
TC	80	24	30	50	210	32	193,300
TC	80	25	30	50	210	32	193,300
TC	80	26	30	50	210	32	193,300
TC	80	28	30	50	210	32	193,300
TC	80	30	30	50	210	32	193,300
TC	90	3	30	50	220	32	213,500
TC	90	4	30	50	220	32	213,500

型番	刃径 (D)	刃幅 (ℓ)	首径 (d1)	首長 (ℓ1)	全長 (L)	シャンク径 (d)	標準価格
TC	90	5	30	50	220	32	213,500
TC	90	6	30	50	220	32	213,500
TC	90	7	30	50	220	32	213,500
TC	90	8	30	50	220	32	213,500
TC	90	9	30	50	220	32	213,500
TC	90	10	30	50	220	32	213,500
TC	90	11	30	50	220	32	224,200
TC	90	12	30	50	220	32	224,200
TC	90	13	30	50	220	32	224,200
TC	90	14	30	50	220	32	224,200
TC	90	15	30	50	220	32	224,200
TC	90	16	30	50	220	32	224,200
TC	90	17	30	50	220	32	224,200
TC	90	18	30	50	220	32	224,200
TC	90	19	30	50	220	32	224,200
TC	90	20	30	50	220	32	224,200
TC	90	22	30	50	220	32	235,100
TC	90	24	30	50	220	32	235,100
TC	90	25	30	50	220	32	235,100
TC	90	26	30	50	220	32	235,100
TC	90	28	30	50	220	32	235,100
TC	90	30	30	50	220	32	235,100
TC	100	3	30	50	230	32	244,400
TC	100	4	30	50	230	32	244,400
TC	100	5	30	50	230	32	244,400
TC	100	6	30	50	230	32	244,400
TC	100	7	30	50	230	32	244,400
TC	100	8	30	50	230	32	244,400
TC	100	9	30	50	230	32	244,400
TC	100	10	30	50	230	32	244,400
TC	100	11	30	50	230	32	256,900
TC	100	12	30	50	230	32	256,900
TC	100	13	30	50	230	32	256,900
TC	100	14	30	50	230	32	256,900
TC	100	15	30	50	230	32	256,900
TC	100	16	30	50	230	32	256,900
TC	100	17	30	50	230	32	256,900
TC	100	18	30	50	230	32	256,900
TC	100	19	30	50	230	32	256,900
TC	100	20	30	50	230	32	256,900
TC	100	22	30	50	230	32	269,000
TC	100	24	30	50	230	32	269,000
TC	100	25	30	50	230	32	269,000
TC	100	26	30	50	230	32	269,000
TC	100	28	30	50	230	32	269,000
TC	100	30	30	50	230	32	269,000

# (LS-TC) ロングシャンクTスロットカッター

SINCE 1935  
F.K.D.®

T-Slot Cutters, Straight Tooth, Long Shank

刃径公差  
 $D \leq 16$   $-0.050 \sim -0.160$   
 $16 < D \leq 30$   $-0.065 \sim -0.195$   
 $30 < D \leq 45$   $-0.080 \sim -0.240$   
 $45 < D \leq 50$   $-0.100 \sim -0.290$

刃数  
 $\phi 10 \sim 15$  8枚  
 $\phi 20 \sim 25$  10枚  
 $\phi 30 \sim 40$  12枚  
 $\phi 45 \sim 50$  14枚

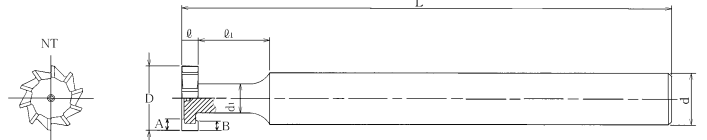

刃幅公差=0~+0.1  
 材質=HSS-Co

●注文例=型番、刃径、刃幅、数量「LS-TC 10x2」 ※両サイド刃の長さはP94に掲載。

型番	刃径 (D)	刃幅 (l)	首径 (d1)	首長 (l1)	全長 (L)	シャンク径 (d)	標準価格
LS-TC	10	2	4	15	130	10	14,400
LS-TC	10	2.5	4	15	130	10	14,400
LS-TC	10	3	4	15	130	10	13,200
LS-TC	10	3.5	4	15	130	10	13,200
LS-TC	10	4	4	15	130	10	13,200
LS-TC	10	4.5	4	15	130	10	13,200
LS-TC	10	5	4	15	130	10	13,200
LS-TC	10	6	4	15	130	10	13,200
LS-TC	10	7	4	15	130	10	13,200
LS-TC	10	8	4	15	130	10	13,200
LS-TC	10	10	4	15	130	10	13,200
LS-TC	12	2	5	15	130	10	14,400
LS-TC	12	2.5	5	15	130	10	14,400
LS-TC	12	3	5	15	130	10	13,200
LS-TC	12	3.5	5	15	130	10	13,200
LS-TC	12	4	5	15	130	10	13,200
LS-TC	12	4.5	5	15	130	10	13,200
LS-TC	12	5	5	15	130	10	13,200
LS-TC	12	6	5	15	130	10	13,200
LS-TC	12	7	5	15	130	10	13,200
LS-TC	12	8	5	15	130	10	13,200
LS-TC	15	2	6	20	135	12	15,000
LS-TC	15	2.5	6	20	135	12	15,000
LS-TC	15	3	6	20	135	12	13,600
LS-TC	15	3.5	6	20	135	12	13,600
LS-TC	15	4	6	20	135	12	13,600
LS-TC	15	4.5	6	20	135	12	13,600
LS-TC	15	5	6	20	135	12	13,600
LS-TC	15	6	6	20	135	12	13,600
LS-TC	15	7	6	20	135	12	13,600
LS-TC	15	8	6	20	135	12	13,600
LS-TC	15	9	6	20	135	12	13,600
LS-TC	15	10	6	20	135	12	13,600
LS-TC	15	12	6	20	135	12	14,300
LS-TC	20	2	9	22	150	16	20,400
LS-TC	20	2.5	9	22	150	16	20,400
LS-TC	20	3	9	22	150	16	18,600
LS-TC	20	3.5	9	22	150	16	18,600
LS-TC	20	4	9	22	150	16	18,600
LS-TC	20	4.5	9	22	150	16	18,600
LS-TC	20	5	9	22	150	16	18,600
LS-TC	20	6	9	22	150	16	18,600
LS-TC	20	7	9	22	150	16	18,600
LS-TC	20	8	9	22	150	16	18,600
LS-TC	20	9	9	22	150	16	18,600

型番	刃径 (D)	刃幅 (l)	首径 (d1)	首長 (l1)	全長 (L)	シャンク径 (d)	標準価格
LS-TC	20	10	9	22	150	16	18,600
LS-TC	20	12	9	22	150	16	19,500
LS-TC	25	2	11	24	150	16	26,100
LS-TC	25	2.5	11	24	150	16	26,100
LS-TC	25	3	11	24	150	16	23,700
LS-TC	25	3.5	11	24	150	16	23,700
LS-TC	25	4	11	24	150	16	23,700
LS-TC	25	4.5	11	24	150	16	23,700
LS-TC	25	5	11	24	150	16	23,700
LS-TC	25	6	11	24	150	16	23,700
LS-TC	25	7	11	24	150	16	23,700
LS-TC	25	8	11	24	150	16	23,700
LS-TC	25	9	11	24	150	16	23,700
LS-TC	25	10	11	24	150	16	23,700
LS-TC	25	12	11	24	150	16	25,100
LS-TC	30	2	13	26	150	16	36,900
LS-TC	30	2.5	13	26	150	16	36,900
LS-TC	30	3	13	26	150	16	33,700
LS-TC	30	3.5	13	26	150	16	33,700
LS-TC	30	4	13	26	150	16	33,700
LS-TC	30	4.5	13	26	150	16	33,700
LS-TC	30	5	13	26	150	16	33,700
LS-TC	30	6	13	26	150	16	33,700
LS-TC	30	7	13	26	150	16	33,700
LS-TC	30	8	13	26	150	16	33,700
LS-TC	30	9	13	26	150	16	33,700
LS-TC	30	10	13	26	150	16	33,700
LS-TC	30	12	13	26	150	16	35,100
LS-TC	30	14	13	26	150	16	35,100
LS-TC	30	15	13	26	150	16	35,100
LS-TC	35	2	15	28	150	16	42,900
LS-TC	35	2.5	15	28	150	16	42,900
LS-TC	35	3	15	28	150	16	38,900
LS-TC	35	3.5	15	28	150	16	38,900
LS-TC	35	4	15	28	150	16	38,900
LS-TC	35	4.5	15	28	150	16	38,900
LS-TC	35	5	15	28	150	16	38,900
LS-TC	35	6	15	28	150	16	38,900
LS-TC	35	7	15	28	150	16	38,900
LS-TC	35	8	15	28	150	16	38,900
LS-TC	35	9	15	28	150	16	38,900
LS-TC	35	10	15	28	150	16	38,900
LS-TC	35	12	15	28	150	16	40,800
LS-TC	35	14	15	28	150	16	40,800
LS-TC	35	15	15	28	150	16	40,800

# (LS-TC) ロングシャンクTスロットカッター

SINCE 1935  
F.K.D.®

T-Slot Cutters, Straight Tooth, Long Shank

刃径公差  
 $D \leq 16$   $-0.050 \sim -0.160$   
 $16 < D \leq 30$   $-0.065 \sim -0.195$   
 $30 < D \leq 45$   $-0.080 \sim -0.240$   
 $45 < D \leq 50$   $-0.100 \sim -0.290$

刃数  
 $\phi 10 \sim 15$  8枚  
 $\phi 20 \sim 25$  10枚  
 $\phi 30 \sim 40$  12枚  
 $\phi 45 \sim 50$  14枚

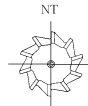

刃幅公差 =  $0 \sim +0.1$   
 材質 = HSS-Co

●注文例 = 型番、刃径、刃幅、数量 「LS-TC 40x2」 ※両サイド刃の長さはP94に掲載。

型番	刃径 (D)	刃幅 (ℓ)	首径 (d1)	首長 (ℓ1)	全長 (L)	シャンク径 (d)	標準価格
LS-TC	40	2	19	34	180	20	61,500
LS-TC	40	2.5	19	34	180	20	61,500
LS-TC	40	3	19	34	180	20	56,000
LS-TC	40	3.5	19	34	180	20	56,000
LS-TC	40	4	19	34	180	20	56,000
LS-TC	40	4.5	19	34	180	20	56,000
LS-TC	40	5	19	34	180	20	56,000
LS-TC	40	6	19	34	180	20	56,000
LS-TC	40	7	19	34	180	20	56,000
LS-TC	40	8	19	34	180	20	56,000
LS-TC	40	9	19	34	180	20	56,000
LS-TC	40	10	19	34	180	20	56,000
LS-TC	40	12	19	34	180	20	58,500
LS-TC	40	14	19	34	180	20	58,500
LS-TC	40	15	19	34	180	20	58,500
LS-TC	40	16	19	34	180	20	58,500
LS-TC	45	2	20	38	200	25	78,500
LS-TC	45	2.5	20	38	200	25	78,500
LS-TC	45	3	20	38	200	25	71,400
LS-TC	45	3.5	20	38	200	25	71,400
LS-TC	45	4	20	38	200	25	71,400
LS-TC	45	4.5	20	38	200	25	71,400
LS-TC	45	5	20	38	200	25	71,400
LS-TC	45	6	20	38	200	25	71,400

型番	刃径 (D)	刃幅 (ℓ)	首径 (d1)	首長 (ℓ1)	全長 (L)	シャンク径 (d)	標準価格
LS-TC	45	7	20	38	200	25	71,400
LS-TC	45	8	20	38	200	25	71,400
LS-TC	45	9	20	38	200	25	71,400
LS-TC	45	10	20	38	200	25	71,400
LS-TC	45	12	20	38	200	25	74,900
LS-TC	45	14	20	38	200	25	74,900
LS-TC	45	15	20	38	200	25	74,900
LS-TC	45	16	20	38	200	25	74,900
LS-TC	50	2	20	40	200	25	85,300
LS-TC	50	2.5	20	40	200	25	85,300
LS-TC	50	3	20	40	200	25	77,400
LS-TC	50	3.5	20	40	200	25	77,400
LS-TC	50	4	20	40	200	25	77,400
LS-TC	50	4.5	20	40	200	25	77,400
LS-TC	50	5	20	40	200	25	77,400
LS-TC	50	6	20	40	200	25	77,400
LS-TC	50	7	20	40	200	25	77,400
LS-TC	50	8	20	40	200	25	77,400
LS-TC	50	9	20	40	200	25	77,400
LS-TC	50	10	20	40	200	25	77,400
LS-TC	50	12	20	40	200	25	81,300
LS-TC	50	14	20	40	200	25	81,300
LS-TC	50	15	20	40	200	25	81,300
LS-TC	50	16	20	40	200	25	81,300

# (STC) 千鳥刃Tスロットカッター

SINCE 1935  
F.K.D.®

T-Slot Cutters, Staggered Tooth

刃径公差  
 $D \leq 16$   $-0.050 \sim -0.160$   
 $16 < D \leq 30$   $-0.065 \sim -0.195$   
 $30 < D \leq 45$   $-0.080 \sim -0.240$   
 $45 < D \leq 100$   $-0.100 \sim -0.290$

刃数  
 $\phi 10 \sim 22$  6枚  
 $\phi 24 \sim 42$  8枚  
 $\phi 45 \sim 50$  10枚  
 $\phi 55 \sim 60$  12枚  
 $\phi 65 \sim 70$  14枚  
 $\phi 75 \sim 80$  16枚  
 $\phi 90 \sim 100$  18枚

刃幅公差=0~+0.1  
 材質=HSS-Co

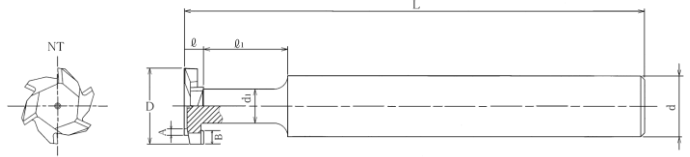

左右捩れ角=15°  $\phi \leq 20$   
 左右捩れ角=12°  $\phi \geq 21$

●注文例=型番、刃径、刃幅、数量「STC 10x2」 ※両サイド刃の長さはP94に掲載。

型番	刃径 (D)	刃幅 (ℓ)	首径 (d1)	首長 (ℓ1)	全長 (L)	シャンク径 (d)	標準価格
STC	10	2	4	15	110	10	13,800
STC	10	2.5	4	15	110	10	13,800
STC	10	3	4	15	110	10	12,700
STC	10	3.5	4	15	110	10	12,700
STC	10	4	4	15	110	10	12,700
STC	10	4.5	4	15	110	10	12,700
STC	10	5	4	15	110	10	12,700
STC	10	5.5	4	15	110	10	12,700
STC	10	6	4	15	110	10	12,700
STC	10	7	4	15	110	10	12,700
STC	10	8	4	15	110	10	12,700
STC	10	9	4	15	110	10	12,700
STC	10	10	4	15	110	10	12,700
STC	12	2	5	15	110	10	13,800
STC	12	2.5	5	15	110	10	13,800
STC	12	3	5	15	110	10	12,700
STC	12	3.5	5	15	110	10	12,700
STC	12	4	5	15	110	10	12,700
STC	12	4.5	5	15	110	10	12,700
STC	12	5	5	15	110	10	12,700
STC	12	5.5	5	15	110	10	12,700
STC	12	6	5	15	110	10	12,700
STC	12	7	5	15	110	10	12,700
STC	12	8	5	15	110	10	12,700
STC	12	9	5	15	110	10	12,700
STC	12	10	5	15	110	10	12,700
STC	12	12	5	15	110	10	13,400
STC	12	13	5	15	110	10	13,400
STC	12	14	5	15	110	10	13,400
STC	13	2	5	15	110	10	14,600
STC	13	2.5	5	15	110	10	14,600
STC	13	3	5	15	110	10	13,400
STC	13	3.5	5	15	110	10	13,400
STC	13	4	5	15	110	10	13,400
STC	13	4.5	5	15	110	10	13,400
STC	13	5	5	15	110	10	13,400
STC	13	5.5	5	15	110	10	13,400
STC	13	6	5	15	110	10	13,400
STC	13	7	5	15	110	10	13,400
STC	13	8	5	15	110	10	13,400
STC	13	9	5	15	110	10	13,400
STC	13	10	5	15	110	10	13,400
STC	13	12	5	15	110	10	14,000
STC	15	2	6	20	115	16	16,100
STC	15	2.5	6	20	115	16	16,100
STC	15	3	6	20	115	16	14,600

型番	刃径 (D)	刃幅 (ℓ)	首径 (d1)	首長 (ℓ1)	全長 (L)	シャンク径 (d)	標準価格
STC	15	3.5	6	20	115	16	14,600
STC	15	4	6	20	115	16	14,600
STC	15	4.5	6	20	115	16	14,600
STC	15	5	6	20	115	16	14,600
STC	15	5.5	6	20	115	16	14,600
STC	15	6	6	20	115	16	14,600
STC	15	7	6	20	115	16	14,600
STC	15	8	6	20	115	16	14,600
STC	15	9	6	20	115	16	14,600
STC	15	10	6	20	115	16	14,600
STC	15	11	6	20	115	16	15,400
STC	15	12	6	20	115	16	15,400
STC	15	13	6	20	115	16	15,400
STC	15	14	6	20	115	16	15,400
STC	16	2	7	20	115	16	17,400
STC	16	2.5	7	20	115	16	17,400
STC	16	3	7	20	115	16	15,500
STC	16	3.5	7	20	115	16	15,500
STC	16	4	7	20	115	16	15,500
STC	16	4.5	7	20	115	16	15,500
STC	16	5	7	20	115	16	15,500
STC	16	5.5	7	20	115	16	15,500
STC	16	6	7	20	115	16	15,500
STC	16	7	7	20	115	16	15,500
STC	16	8	7	20	115	16	15,500
STC	16	9	7	20	115	16	15,500
STC	16	10	7	20	115	16	15,500
STC	16	11	7	20	115	16	16,300
STC	16	12	7	20	115	16	16,300
STC	16	13	7	20	115	16	16,300
STC	16	14	7	20	115	16	16,300
STC	16	15	7	20	115	16	16,300
STC	16	16	7	20	115	16	16,300
STC	18	2	8	22	120	16	18,600
STC	18	2.5	8	22	120	16	18,600
STC	18	3	8	22	120	16	16,800
STC	18	3.5	8	22	120	16	16,800
STC	18	4	8	22	120	16	16,800
STC	18	4.5	8	22	120	16	16,800
STC	18	5	8	22	120	16	16,800
STC	18	5.5	8	22	120	16	16,800
STC	18	6	8	22	120	16	16,800
STC	18	7	8	22	120	16	16,800
STC	18	8	8	22	120	16	16,800
STC	18	9	8	22	120	16	16,800
STC	18	10	8	22	120	16	16,800

# (STC) 千鳥刃Tスロットカッター

SINCE 1935  
F.K.D.®

T-Slot Cutters, Staggered Tooth

刃径公差  
 $D \leq 16$   $-0.050 \sim -0.160$   
 $16 < D \leq 30$   $-0.065 \sim -0.195$   
 $30 < D \leq 45$   $-0.080 \sim -0.240$   
 $45 < D \leq 100$   $-0.100 \sim -0.290$

刃数  
 $\phi 10 \sim 22$  6枚  
 $\phi 24 \sim 42$  8枚  
 $\phi 45 \sim 50$  10枚  
 $\phi 55 \sim 60$  12枚  
 $\phi 65 \sim 70$  14枚  
 $\phi 75 \sim 80$  16枚  
 $\phi 90 \sim 100$  18枚

刃幅公差=0~+0.1  
 材質=HSS-Co

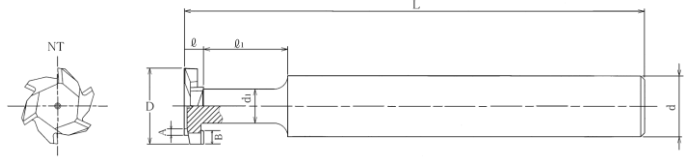

左右捩れ角=15°  $\phi \leq 20$   
 左右捩れ角=12°  $\phi \geq 21$

●注文例=型番、刃径、刃幅、数量「STC 18x11」 ※両サイド刃の長さはP94に掲載。

型番	刃径 (D)	刃幅 (ℓ)	首径 (d1)	首長 (ℓ1)	全長 (L)	シャンク径 (d)	標準価格
STC	18	11	8	22	120	16	17,700
STC	18	12	8	22	120	16	17,700
STC	18	13	8	22	120	16	17,700
STC	18	14	8	22	120	16	17,700
STC	18	15	8	22	120	16	17,700
STC	18	16	8	22	120	16	17,700
STC	19	2	9	22	120	16	20,400
STC	19	2.5	9	22	120	16	20,400
STC	19	3	9	22	120	16	18,600
STC	19	3.5	9	22	120	16	18,600
STC	19	4	9	22	120	16	18,600
STC	19	4.5	9	22	120	16	18,600
STC	19	5	9	22	120	16	18,600
STC	19	5.5	9	22	120	16	18,600
STC	19	6	9	22	120	16	18,600
STC	19	7	9	22	120	16	18,600
STC	19	8	9	22	120	16	18,600
STC	19	9	9	22	120	16	18,600
STC	19	10	9	22	120	16	18,600
STC	19	11	9	22	120	16	19,500
STC	19	12	9	22	120	16	19,500
STC	19	13	9	22	120	16	19,500
STC	19	14	9	22	120	16	19,500
STC	19	15	9	22	120	16	19,500
STC	19	16	9	22	120	16	19,500
STC	20	2	9	22	120	16	20,400
STC	20	2.5	9	22	120	16	20,400
STC	20	3	9	22	120	16	18,600
STC	20	3.5	9	22	120	16	18,600
STC	20	4	9	22	120	16	18,600
STC	20	4.5	9	22	120	16	18,600
STC	20	5	9	22	120	16	18,600
STC	20	5.5	9	22	120	16	18,600
STC	20	6	9	22	120	16	18,600
STC	20	7	9	22	120	16	18,600
STC	20	8	9	22	120	16	18,600
STC	20	9	9	22	120	16	18,600
STC	20	10	9	22	120	16	18,600
STC	20	11	9	22	120	16	19,500
STC	20	12	9	22	120	16	19,500
STC	20	13	9	22	120	16	19,500
STC	20	14	9	22	120	16	19,500
STC	20	15	9	22	120	16	19,500
STC	20	16	9	22	120	16	19,500
STC	22	2	9.5	22	120	16	22,700
STC	22	2.5	9.5	22	120	16	22,700

型番	刃径 (D)	刃幅 (ℓ)	首径 (d1)	首長 (ℓ1)	全長 (L)	シャンク径 (d)	標準価格
STC	22	3	9.5	22	120	16	20,500
STC	22	3.5	9.5	22	120	16	20,500
STC	22	4	9.5	22	120	16	20,500
STC	22	4.5	9.5	22	120	16	20,500
STC	22	5	9.5	22	120	16	20,500
STC	22	5.5	9.5	22	120	16	20,500
STC	22	6	9.5	22	120	16	20,500
STC	22	7	9.5	22	120	16	20,500
STC	22	8	9.5	22	120	16	20,500
STC	22	9	9.5	22	120	16	20,500
STC	22	10	9.5	22	120	16	20,500
STC	22	11	9.5	22	120	16	21,700
STC	22	12	9.5	22	120	16	21,700
STC	22	13	9.5	22	120	16	21,700
STC	22	14	9.5	22	120	16	21,700
STC	22	15	9.5	22	120	16	21,700
STC	22	16	9.5	22	120	16	21,700
STC	24	2	10	24	125	16	26,400
STC	24	2.5	10	24	125	16	26,400
STC	24	3	10	24	125	16	24,100
STC	24	3.5	10	24	125	16	24,100
STC	24	4	10	24	125	16	24,100
STC	24	4.5	10	24	125	16	24,100
STC	24	5	10	24	125	16	24,100
STC	24	5.5	10	24	125	16	24,100
STC	24	6	10	24	125	16	24,100
STC	24	7	10	24	125	16	24,100
STC	24	8	10	24	125	16	24,100
STC	24	9	10	24	125	16	24,100
STC	24	10	10	24	125	16	24,100
STC	24	11	10	24	125	16	25,300
STC	24	12	10	24	125	16	25,300
STC	24	13	10	24	125	16	25,300
STC	24	14	10	24	125	16	25,300
STC	24	15	10	24	125	16	25,300
STC	24	16	10	24	125	16	25,300
STC	25	2	11	24	125	16	26,400
STC	25	2.5	11	24	125	16	26,400
STC	25	3	11	24	125	16	24,100
STC	25	3.5	11	24	125	16	24,100
STC	25	4	11	24	125	16	24,100
STC	25	4.5	11	24	125	16	24,100
STC	25	5	11	24	125	16	24,100
STC	25	5.5	11	24	125	16	24,100
STC	25	6	11	24	125	16	24,100
STC	25	7	11	24	125	16	24,100

# (STC) 千鳥刃Tスロットカッター

SINCE 1935  
F.K.D.®

T-Slot Cutters, Staggered Tooth

刃径公差

$D \leq 16$  -0.050~-0.160  
 $16 < D \leq 30$  -0.065~-0.195  
 $30 < D \leq 45$  -0.080~-0.240  
 $45 < D \leq 100$  -0.100~-0.290

刃幅公差=0~+0.1

材質=HSS-Co

刃数

$\phi 10 \sim 22$  6枚  
 $\phi 24 \sim 42$  8枚  
 $\phi 45 \sim 50$  10枚  
 $\phi 55 \sim 60$  12枚  
 $\phi 65 \sim 70$  14枚  
 $\phi 75 \sim 80$  16枚  
 $\phi 90 \sim 100$  18枚

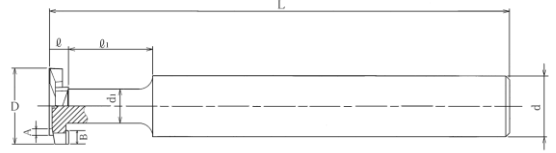
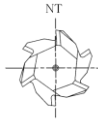

左右捩れ角=15°  $\phi \leq 20$   
 左右捩れ角=12°  $\phi \geq 21$

●注文例=型番、刃径、刃幅、数量「STC 25x8」 ※両サイド刃の長さはP94に掲載。

型番	刃径 (D)	刃幅 (ℓ)	首径 (d1)	首長 (ℓ1)	全長 (L)	シャフト径 (d)	標準価格
STC	25	8	11	24	125	16	24,100
STC	25	9	11	24	125	16	24,100
STC	25	10	11	24	125	16	24,100
STC	25	11	11	24	125	16	25,300
STC	25	12	11	24	125	16	25,300
STC	25	13	11	24	125	16	25,300
STC	25	14	11	24	125	16	25,300
STC	25	15	11	24	125	16	25,300
STC	25	16	11	24	125	16	25,300
STC	25	18	11	24	125	16	25,300
STC	25	20	11	24	125	16	25,300
STC	26	2	11	24	125	16	31,800
STC	26	2.5	11	24	125	16	31,800
STC	26	3	11	24	125	16	28,700
STC	26	3.5	11	24	125	16	28,700
STC	26	4	11	24	125	16	28,700
STC	26	4.5	11	24	125	16	28,700
STC	26	5	11	24	125	16	28,700
STC	26	5.5	11	24	125	16	28,700
STC	26	6	11	24	125	16	28,700
STC	26	7	11	24	125	16	28,700
STC	26	8	11	24	125	16	28,700
STC	26	9	11	24	125	16	28,700
STC	26	10	11	24	125	16	28,700
STC	26	11	11	24	125	16	30,300
STC	26	12	11	24	125	16	30,300
STC	26	13	11	24	125	16	30,300
STC	26	14	11	24	125	16	30,300
STC	26	15	11	24	125	16	30,300
STC	26	16	11	24	125	16	30,300
STC	26	18	11	24	125	16	30,300
STC	26	20	11	24	125	16	30,300
STC	28	2	11	24	125	16	31,800
STC	28	2.5	11	24	125	16	31,800
STC	28	3	11	24	125	16	28,700
STC	28	3.5	11	24	125	16	28,700
STC	28	4	11	24	125	16	28,700
STC	28	4.5	11	24	125	16	28,700
STC	28	5	11	24	125	16	28,700
STC	28	5.5	11	24	125	16	28,700
STC	28	6	11	24	125	16	28,700
STC	28	7	11	24	125	16	28,700
STC	28	8	11	24	125	16	28,700
STC	28	9	11	24	125	16	28,700
STC	28	10	11	24	125	16	28,700
STC	28	11	11	24	125	16	30,300

型番	刃径 (D)	刃幅 (ℓ)	首径 (d1)	首長 (ℓ1)	全長 (L)	シャフト径 (d)	標準価格
STC	28	12	11	24	125	16	30,300
STC	28	13	11	24	125	16	30,300
STC	28	14	11	24	125	16	30,300
STC	28	15	11	24	125	16	30,300
STC	28	16	11	24	125	16	30,300
STC	28	18	11	24	125	16	30,300
STC	28	20	11	24	125	16	30,300
STC	30	2	13	26	125	20	36,900
STC	30	2.5	13	26	125	20	36,900
STC	30	3	13	26	125	20	33,700
STC	30	3.5	13	26	125	20	33,700
STC	30	4	13	26	125	20	33,700
STC	30	4.5	13	26	125	20	33,700
STC	30	5	13	26	125	20	33,700
STC	30	5.5	13	26	125	20	33,700
STC	30	6	13	26	125	20	33,700
STC	30	7	13	26	125	20	33,700
STC	30	8	13	26	125	20	33,700
STC	30	9	13	26	125	20	33,700
STC	30	10	13	26	125	20	33,700
STC	30	11	13	26	125	20	35,100
STC	30	12	13	26	125	20	35,100
STC	30	13	13	26	125	20	35,100
STC	30	14	13	26	125	20	35,100
STC	30	15	13	26	125	20	35,100
STC	30	16	13	26	125	20	35,100
STC	30	17	13	26	125	20	35,100
STC	30	18	13	26	125	20	35,100
STC	30	19	13	26	125	20	35,100
STC	30	20	13	26	125	20	35,100
STC	32	2.5	15	28	130	20	39,900
STC	32	3	15	28	130	20	36,400
STC	32	3.5	15	28	130	20	36,400
STC	32	4	15	28	130	20	36,400
STC	32	4.5	15	28	130	20	36,400
STC	32	5	15	28	130	20	36,400
STC	32	5.5	15	28	130	20	36,400
STC	32	6	15	28	130	20	36,400
STC	32	7	15	28	130	20	36,400
STC	32	8	15	28	130	20	36,400
STC	32	9	15	28	130	20	36,400
STC	32	10	15	28	130	20	36,400
STC	32	11	15	28	130	20	38,100
STC	32	12	15	28	130	20	38,100
STC	32	13	15	28	130	20	38,100
STC	32	14	15	28	130	20	38,100

# (STC) 千鳥刃Tスロットカッター

SINCE 1935  
F.K.D.®

T-Slot Cutters, Staggered Tooth

刃径公差  
 $D \leq 16$   $-0.050 \sim -0.160$   
 $16 < D \leq 30$   $-0.065 \sim -0.195$   
 $30 < D \leq 45$   $-0.080 \sim -0.240$   
 $45 < D \leq 100$   $-0.100 \sim -0.290$

刃数  
 $\phi 10 \sim 22$  6枚  
 $\phi 24 \sim 42$  8枚  
 $\phi 45 \sim 50$  10枚  
 $\phi 55 \sim 60$  12枚  
 $\phi 65 \sim 70$  14枚  
 $\phi 75 \sim 80$  16枚  
 $\phi 90 \sim 100$  18枚

刃幅公差=0~+0.1  
 材質=HSS-Co

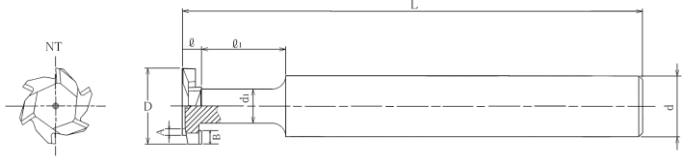

左右捩れ角=15°  $\phi \leq 20$   
 左右捩れ角=12°  $\phi \geq 21$

●注文例=型番、刃径、刃幅、数量「STC 32x15」 ※両サイド刃の長さはP94に掲載。

型番	刃径 (D)	刃幅 (ℓ)	首径 (d1)	首長 (ℓ1)	全長 (L)	シャンク径 (d)	標準価格
STC	32	15	15	28	130	20	38,100
STC	32	16	15	28	130	20	38,100
STC	32	17	15	28	130	20	38,100
STC	32	18	15	28	130	20	38,100
STC	32	19	15	28	130	20	38,100
STC	32	20	15	28	130	20	38,100
STC	35	2.5	17	28	130	20	41,800
STC	35	3	17	28	130	20	38,100
STC	35	3.5	17	28	130	20	38,100
STC	35	4	17	28	130	20	38,100
STC	35	4.5	17	28	130	20	38,100
STC	35	5	17	28	130	20	38,100
STC	35	5.5	17	28	130	20	38,100
STC	35	6	17	28	130	20	38,100
STC	35	7	17	28	130	20	38,100
STC	35	8	17	28	130	20	38,100
STC	35	9	17	28	130	20	38,100
STC	35	10	17	28	130	20	38,100
STC	35	11	17	28	130	20	39,900
STC	35	12	17	28	130	20	39,900
STC	35	13	17	28	130	20	39,900
STC	35	14	17	28	130	20	39,900
STC	35	15	17	28	130	20	39,900
STC	35	16	17	28	130	20	39,900
STC	35	17	17	28	130	20	39,900
STC	35	18	17	28	130	20	39,900
STC	35	19	17	28	130	20	39,900
STC	35	20	17	28	130	20	39,900
STC	35	22	17	28	130	20	41,800
STC	35	24	17	28	130	20	41,800
STC	35	25	17	28	130	20	41,800
STC	36	2.5	17	28	130	20	51,400
STC	36	3	17	28	130	20	46,600
STC	36	3.5	17	28	130	20	46,600
STC	36	4	17	28	130	20	46,600
STC	36	4.5	17	28	130	20	46,600
STC	36	5	17	28	130	20	46,600
STC	36	5.5	17	28	130	20	46,600
STC	36	6	17	28	130	20	46,600
STC	36	7	17	28	130	20	46,600
STC	36	8	17	28	130	20	46,600
STC	36	9	17	28	130	20	46,600
STC	36	10	17	28	130	20	46,600
STC	36	11	17	28	130	20	48,800
STC	36	12	17	28	130	20	48,800
STC	36	13	17	28	130	20	48,800

型番	刃径 (D)	刃幅 (ℓ)	首径 (d1)	首長 (ℓ1)	全長 (L)	シャンク径 (d)	標準価格
STC	36	14	17	28	130	20	48,800
STC	36	15	17	28	130	20	48,800
STC	36	16	17	28	130	20	48,800
STC	36	17	17	28	130	20	48,800
STC	36	18	17	28	130	20	48,800
STC	36	19	17	28	130	20	48,800
STC	36	20	17	28	130	20	48,800
STC	36	22	17	28	130	20	51,400
STC	36	24	17	28	130	20	51,400
STC	36	25	17	28	130	20	51,400
STC	38	2.5	18	34	135	25	51,400
STC	38	3	18	34	135	25	46,600
STC	38	3.5	18	34	135	25	46,600
STC	38	4	18	34	135	25	46,600
STC	38	4.5	18	34	135	25	46,600
STC	38	5	18	34	135	25	46,600
STC	38	5.5	18	34	135	25	46,600
STC	38	6	18	34	135	25	46,600
STC	38	7	18	34	135	25	46,600
STC	38	8	18	34	135	25	46,600
STC	38	9	18	34	135	25	46,600
STC	38	10	18	34	135	25	46,600
STC	38	11	18	34	135	25	48,800
STC	38	12	18	34	135	25	48,800
STC	38	13	18	34	135	25	48,800
STC	38	14	18	34	135	25	48,800
STC	38	15	18	34	135	25	48,800
STC	38	16	18	34	135	25	48,800
STC	38	17	18	34	135	25	48,800
STC	38	18	18	34	135	25	48,800
STC	38	19	18	34	135	25	48,800
STC	38	20	18	34	135	25	48,800
STC	38	22	18	34	135	25	51,400
STC	38	24	18	34	135	25	51,400
STC	38	25	18	34	135	25	51,400
STC	40	2.5	19	34	135	25	60,700
STC	40	3	19	34	135	25	55,100
STC	40	3.5	19	34	135	25	55,100
STC	40	4	19	34	135	25	55,100
STC	40	4.5	19	34	135	25	55,100
STC	40	5	19	34	135	25	55,100
STC	40	5.5	19	34	135	25	55,100
STC	40	6	19	34	135	25	55,100
STC	40	7	19	34	135	25	55,100
STC	40	8	19	34	135	25	55,100
STC	40	9	19	34	135	25	55,100



# (STC) 千鳥刃Tスロットカッター

T-Slot Cutters, Staggered Tooth

SINCE 1935  
**F.K.D.**®

刃径公差

$D \leq 16$   $-0.050 \sim -0.160$   
 $16 < D \leq 30$   $-0.065 \sim -0.195$   
 $30 < D \leq 45$   $-0.080 \sim -0.240$   
 $45 < D \leq 100$   $-0.100 \sim -0.290$

刃幅公差 = 0 ~ +0.1

材質 = HSS-Co

刃数

$\phi 10 \sim 22$  6枚  
 $\phi 24 \sim 42$  8枚  
 $\phi 45 \sim 50$  10枚  
 $\phi 55 \sim 60$  12枚  
 $\phi 65 \sim 70$  14枚  
 $\phi 75 \sim 80$  16枚  
 $\phi 90 \sim 100$  18枚

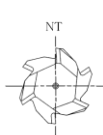

左右捩れ角 = 15°  $l \leq 20$

左右捩れ角 = 12°  $l \geq 21$

●注文例 = 型番、刃径、刃幅、数量 「STC 40x10」 ※両サイド刃の長さはP94に掲載。

型番	刃径 (D)	刃幅 (l)	首径 (d1)	首長 (l1)	全長 (L)	シャンク径 (d)	標準価格
STC	40	10	19	34	135	25	55,100
STC	40	11	19	34	135	25	58,100
STC	40	12	19	34	135	25	58,100
STC	40	13	19	34	135	25	58,100
STC	40	14	19	34	135	25	58,100
STC	40	15	19	34	135	25	58,100
STC	40	16	19	34	135	25	58,100
STC	40	17	19	34	135	25	58,100
STC	40	18	19	34	135	25	58,100
STC	40	19	19	34	135	25	58,100
STC	40	20	19	34	135	25	58,100
STC	40	22	19	34	135	25	60,700
STC	40	24	19	34	135	25	60,700
STC	40	25	19	34	135	25	60,700
STC	40	26	19	34	135	25	60,700
STC	40	28	19	34	135	25	60,700
STC	40	30	19	34	135	25	60,700
STC	42	2.5	19	34	135	25	77,700
STC	42	3	19	34	135	25	70,700
STC	42	3.5	19	34	135	25	70,700
STC	42	4	19	34	135	25	70,700
STC	42	4.5	19	34	135	25	70,700
STC	42	5	19	34	135	25	70,700
STC	42	5.5	19	34	135	25	70,700
STC	42	6	19	34	135	25	70,700
STC	42	7	19	34	135	25	70,700
STC	42	8	19	34	135	25	70,700
STC	42	9	19	34	135	25	70,700
STC	42	10	19	34	135	25	70,700
STC	42	11	19	34	135	25	74,400
STC	42	12	19	34	135	25	74,400
STC	42	13	19	34	135	25	74,400
STC	42	14	19	34	135	25	74,400
STC	42	15	19	34	135	25	74,400
STC	42	16	19	34	135	25	74,400
STC	42	17	19	34	135	25	74,400
STC	42	18	19	34	135	25	74,400
STC	42	19	19	34	135	25	74,400
STC	42	20	19	34	135	25	74,400
STC	42	22	19	34	135	25	77,700
STC	42	24	19	34	135	25	77,700
STC	42	25	19	34	135	25	77,700
STC	42	26	19	34	135	25	77,700
STC	42	28	19	34	135	25	77,700
STC	42	30	19	34	135	25	77,700
STC	45	2.5	20	38	140	25	77,700

型番	刃径 (D)	刃幅 (l)	首径 (d1)	首長 (l1)	全長 (L)	シャンク径 (d)	標準価格
STC	45	3	20	38	140	25	70,700
STC	45	3.5	20	38	140	25	70,700
STC	45	4	20	38	140	25	70,700
STC	45	4.5	20	38	140	25	70,700
STC	45	5	20	38	140	25	70,700
STC	45	5.5	20	38	140	25	70,700
STC	45	6	20	38	140	25	70,700
STC	45	7	20	38	140	25	70,700
STC	45	8	20	38	140	25	70,700
STC	45	9	20	38	140	25	70,700
STC	45	10	20	38	140	25	70,700
STC	45	11	20	38	140	25	74,400
STC	45	12	20	38	140	25	74,400
STC	45	13	20	38	140	25	74,400
STC	45	14	20	38	140	25	74,400
STC	45	15	20	38	140	25	74,400
STC	45	16	20	38	140	25	74,400
STC	45	17	20	38	140	25	74,400
STC	45	18	20	38	140	25	74,400
STC	45	19	20	38	140	25	74,400
STC	45	20	20	38	140	25	74,400
STC	45	22	20	38	140	25	77,700
STC	45	24	20	38	140	25	77,700
STC	45	25	20	38	140	25	77,700
STC	45	26	20	38	140	25	77,700
STC	45	28	20	38	140	25	77,700
STC	45	30	20	38	140	25	77,700
STC	48	2.5	20	40	145	25	85,300
STC	48	3	20	40	145	25	77,400
STC	48	3.5	20	40	145	25	77,400
STC	48	4	20	40	145	25	77,400
STC	48	4.5	20	40	145	25	77,400
STC	48	5	20	40	145	25	77,400
STC	48	5.5	20	40	145	25	77,400
STC	48	6	20	40	145	25	77,400
STC	48	7	20	40	145	25	77,400
STC	48	8	20	40	145	25	77,400
STC	48	9	20	40	145	25	77,400
STC	48	10	20	40	145	25	77,400
STC	48	11	20	40	145	25	81,300
STC	48	12	20	40	145	25	81,300
STC	48	13	20	40	145	25	81,300
STC	48	14	20	40	145	25	81,300
STC	48	15	20	40	145	25	81,300
STC	48	16	20	40	145	25	81,300
STC	48	17	20	40	145	25	81,300

(STC)  
千鳥刃Tスロットカッター  
T-Slot Cutters, Staggered Tooth



刃径公差  
 $D \leq 16$   $-0.050 \sim -0.160$   
 $16 < D \leq 30$   $-0.065 \sim -0.195$   
 $30 < D \leq 45$   $-0.080 \sim -0.240$   
 $45 < D \leq 100$   $-0.100 \sim -0.290$

刃数  
 $\phi 10 \sim 22$  6枚  
 $\phi 24 \sim 42$  8枚  
 $\phi 45 \sim 50$  10枚  
 $\phi 55 \sim 60$  12枚  
 $\phi 65 \sim 70$  14枚  
 $\phi 75 \sim 80$  16枚  
 $\phi 90 \sim 100$  18枚

刃幅公差=0~+0.1  
 材質=HSS-Co

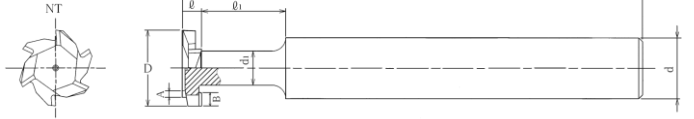

左右傾れ角=15°  $0 \leq 20$   
 左右傾れ角=12°  $0 \geq 21$

●注文例=型番、刃径、刃幅、数量「STC 48x18」 ※両サイド刃の長さはP94に掲載。

型番	刃径 (D)	刃幅 (l)	首径 (d1)	首長 (l1)	全長 (L)	シャンク径 (d)	標準価格
STC	48	18	20	40	145	25	81,300
STC	48	19	20	40	145	25	81,300
STC	48	20	20	40	145	25	81,300
STC	48	22	20	40	145	25	85,300
STC	48	24	20	40	145	25	85,300
STC	48	25	20	40	145	25	85,300
STC	48	26	20	40	145	25	85,300
STC	48	28	20	40	145	25	85,300
STC	48	30	20	40	145	25	85,300
STC	50	2.5	20	40	145	25	85,300
STC	50	3	20	40	145	25	77,400
STC	50	3.5	20	40	145	25	77,400
STC	50	4	20	40	145	25	77,400
STC	50	4.5	20	40	145	25	77,400
STC	50	5	20	40	145	25	77,400
STC	50	5.5	20	40	145	25	77,400
STC	50	6	20	40	145	25	77,400
STC	50	7	20	40	145	25	77,400
STC	50	8	20	40	145	25	77,400
STC	50	9	20	40	145	25	77,400
STC	50	10	20	40	145	25	77,400
STC	50	11	20	40	145	25	81,300
STC	50	12	20	40	145	25	81,300
STC	50	13	20	40	145	25	81,300
STC	50	14	20	40	145	25	81,300
STC	50	15	20	40	145	25	81,300
STC	50	16	20	40	145	25	81,300
STC	50	17	20	40	145	25	81,300
STC	50	18	20	40	145	25	81,300
STC	50	19	20	40	145	25	81,300
STC	50	20	20	40	145	25	81,300
STC	50	22	20	40	145	25	85,300
STC	50	24	20	40	145	25	85,300
STC	50	25	20	40	145	25	85,300
STC	50	26	20	40	145	25	85,300
STC	50	28	20	40	145	25	85,300
STC	50	30	20	40	145	25	85,300
STC	55	2.5	20	42	155	25	101,500
STC	55	3	20	42	155	25	92,200
STC	55	3.5	20	42	155	25	92,200
STC	55	4	20	42	155	25	92,200
STC	55	4.5	20	42	155	25	92,200
STC	55	5	20	42	155	25	92,200
STC	55	5.5	20	42	155	25	92,200
STC	55	6	20	42	155	25	92,200
STC	55	7	20	42	155	25	92,200

型番	刃径 (D)	刃幅 (l)	首径 (d1)	首長 (l1)	全長 (L)	シャンク径 (d)	標準価格
STC	55	8	20	42	155	25	92,200
STC	55	9	20	42	155	25	92,200
STC	55	10	20	42	155	25	92,200
STC	55	11	20	42	155	25	97,100
STC	55	12	20	42	155	25	97,100
STC	55	13	20	42	155	25	97,100
STC	55	14	20	42	155	25	97,100
STC	55	15	20	42	155	25	97,100
STC	55	16	20	42	155	25	97,100
STC	55	17	20	42	155	25	97,100
STC	55	18	20	42	155	25	97,100
STC	55	19	20	42	155	25	97,100
STC	55	20	20	42	155	25	97,100
STC	55	22	20	42	155	25	101,500
STC	55	24	20	42	155	25	101,500
STC	55	25	20	42	155	25	101,500
STC	55	26	20	42	155	25	101,500
STC	55	28	20	42	155	25	101,500
STC	55	30	20	42	155	25	101,500
STC	60	2.5	23	45	170	25	125,300
STC	60	3	23	45	170	25	113,700
STC	60	3.5	23	45	170	25	113,700
STC	60	4	23	45	170	25	113,700
STC	60	4.5	23	45	170	25	113,700
STC	60	5	23	45	170	25	113,700
STC	60	5.5	23	45	170	25	113,700
STC	60	6	23	45	170	25	113,700
STC	60	7	23	45	170	25	113,700
STC	60	8	23	45	170	25	113,700
STC	60	9	23	45	170	25	113,700
STC	60	10	23	45	170	25	113,700
STC	60	11	23	45	170	25	119,600
STC	60	12	23	45	170	25	119,600
STC	60	13	23	45	170	25	119,600
STC	60	14	23	45	170	25	119,600
STC	60	15	23	45	170	25	119,600
STC	60	16	23	45	170	25	119,600
STC	60	17	23	45	170	25	119,600
STC	60	18	23	45	170	25	119,600
STC	60	19	23	45	170	25	119,600
STC	60	20	23	45	170	25	119,600
STC	60	22	23	45	170	25	125,300
STC	60	24	23	45	170	25	125,300
STC	60	25	23	45	170	25	125,300
STC	60	26	23	45	170	25	125,300
STC	60	28	23	45	170	25	125,300

# (STC) 千鳥刃Tスロットカッター



T-Slot Cutters, Staggered Tooth

刃径公差  
 $D \leq 16$   $-0.050 \sim -0.160$   
 $16 < D \leq 30$   $-0.065 \sim -0.195$   
 $30 < D \leq 45$   $-0.080 \sim -0.240$   
 $45 < D \leq 100$   $-0.100 \sim -0.290$

刃数  
 $\phi 10 \sim 22$  6枚  
 $\phi 24 \sim 42$  8枚  
 $\phi 45 \sim 50$  10枚  
 $\phi 55 \sim 60$  12枚  
 $\phi 65 \sim 70$  14枚  
 $\phi 75 \sim 80$  16枚  
 $\phi 90 \sim 100$  18枚

刃幅公差=0~+0.1  
 材質=HSS-Co

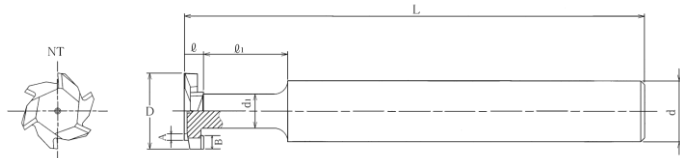

左右扱れ角=15°  $\phi \leq 20$   
 左右扱れ角=12°  $\phi \geq 21$

●注文例=型番、刃径、刃幅、数量「STC 60x30」 ※両サイド刃の長さはP94に掲載。

型番	刃径(D)	刃幅(phi)	首径(d1)	首長(phi1)	全長(L)	シャンク径(d)	標準価格
STC	60	30	23	45	170	25	125,300
STC	65	3	23	50	170	25	132,700
STC	65	3.5	23	50	170	25	132,700
STC	65	4	23	50	170	25	132,700
STC	65	4.5	23	50	170	25	132,700
STC	65	5	23	50	170	25	132,700
STC	65	5.5	23	50	170	25	132,700
STC	65	6	23	50	170	25	132,700
STC	65	7	23	50	170	25	132,700
STC	65	8	23	50	170	25	132,700
STC	65	9	23	50	170	25	132,700
STC	65	10	23	50	170	25	132,700
STC	65	11	23	50	170	25	139,400
STC	65	12	23	50	170	25	139,400
STC	65	13	23	50	170	25	139,400
STC	65	14	23	50	170	25	139,400
STC	65	15	23	50	170	25	139,400
STC	65	16	23	50	170	25	139,400
STC	65	17	23	50	170	25	139,400
STC	65	18	23	50	170	25	139,400
STC	65	19	23	50	170	25	139,400
STC	65	20	23	50	170	25	139,400
STC	65	22	23	50	170	25	145,900
STC	65	24	23	50	170	25	145,900
STC	65	25	23	50	170	25	145,900
STC	65	26	23	50	170	25	145,900
STC	65	28	23	50	170	25	145,900
STC	65	30	23	50	170	25	145,900
STC	70	3	23	50	170	25	151,700
STC	70	3.5	23	50	170	25	151,700
STC	70	4	23	50	170	25	151,700
STC	70	4.5	23	50	170	25	151,700
STC	70	5	23	50	170	25	151,700
STC	70	5.5	23	50	170	25	151,700
STC	70	6	23	50	170	25	151,700
STC	70	7	23	50	170	25	151,700
STC	70	8	23	50	170	25	151,700
STC	70	9	23	50	170	25	151,700
STC	70	10	23	50	170	25	151,700
STC	70	11	23	50	170	25	159,200
STC	70	12	23	50	170	25	159,200
STC	70	13	23	50	170	25	159,200
STC	70	14	23	50	170	25	159,200
STC	70	15	23	50	170	25	159,200
STC	70	16	23	50	170	25	159,200
STC	70	17	23	50	170	25	159,200

型番	刃径(D)	刃幅(phi)	首径(d1)	首長(phi1)	全長(L)	シャンク径(d)	標準価格
STC	70	18	23	50	170	25	159,200
STC	70	19	23	50	170	25	159,200
STC	70	20	23	50	170	25	159,200
STC	70	22	23	50	170	25	166,900
STC	70	24	23	50	170	25	166,900
STC	70	25	23	50	170	25	166,900
STC	70	26	23	50	170	25	166,900
STC	70	28	23	50	170	25	166,900
STC	70	30	23	50	170	25	166,900
STC	75	3	30	50	200	32	170,500
STC	75	3.5	30	50	200	32	170,500
STC	75	4	30	50	200	32	170,500
STC	75	4.5	30	50	200	32	170,500
STC	75	5	30	50	200	32	170,500
STC	75	5.5	30	50	200	32	170,500
STC	75	6	30	50	200	32	170,500
STC	75	7	30	50	200	32	170,500
STC	75	8	30	50	200	32	170,500
STC	75	9	30	50	200	32	170,500
STC	75	10	30	50	200	32	170,500
STC	75	11	30	50	200	32	179,100
STC	75	12	30	50	200	32	179,100
STC	75	13	30	50	200	32	179,100
STC	75	14	30	50	200	32	179,100
STC	75	15	30	50	200	32	179,100
STC	75	16	30	50	200	32	179,100
STC	75	17	30	50	200	32	179,100
STC	75	18	30	50	200	32	179,100
STC	75	19	30	50	200	32	179,100
STC	75	20	30	50	200	32	179,100
STC	75	22	30	50	200	32	187,400
STC	75	24	30	50	200	32	187,400
STC	75	25	30	50	200	32	187,400
STC	75	26	30	50	200	32	187,400
STC	75	28	30	50	200	32	187,400
STC	75	30	30	50	200	32	187,400
STC	80	3	30	50	210	32	213,500
STC	80	4	30	50	210	32	213,500
STC	80	5	30	50	210	32	213,500
STC	80	6	30	50	210	32	213,500
STC	80	7	30	50	210	32	213,500
STC	80	8	30	50	210	32	213,500
STC	80	9	30	50	210	32	213,500
STC	80	10	30	50	210	32	213,500
STC	80	11	30	50	210	32	224,200
STC	80	12	30	50	210	32	224,200

# (STC) 千鳥刃Tスロットカッター

SINCE 1935  
F.K.D.®

T-Slot Cutters, Staggered Tooth

刃径公差  
 $D \leq 16$  -0.050~-0.160  
 $16 < D \leq 30$  -0.065~-0.195  
 $30 < D \leq 45$  -0.080~-0.240  
 $45 < D \leq 100$  -0.100~-0.290

刃数  
 $\phi 10 \sim 22$  6枚  
 $\phi 24 \sim 42$  8枚  
 $\phi 45 \sim 50$  10枚  
 $\phi 55 \sim 60$  12枚  
 $\phi 65 \sim 70$  14枚  
 $\phi 75 \sim 80$  16枚  
 $\phi 90 \sim 100$  18枚

刃幅公差=0~+0.1  
 材質=HSS-Co

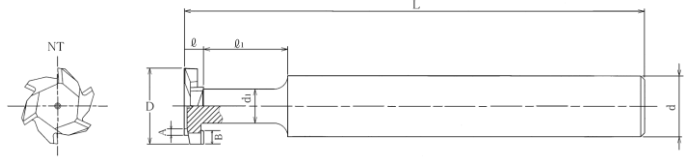

左右捩れ角=15°  $\phi \leq 20$   
 左右捩れ角=12°  $\phi \geq 21$

●注文例=型番、刃径、刃幅、数量「STC 80x13」 ※両サイド刃の長さはP94に掲載。

型番	刃径 (D)	刃幅 (l)	首径 (d1)	首長 (l1)	全長 (L)	シャンク径 (d)	標準価格
STC	80	13	30	50	210	32	224,200
STC	80	14	30	50	210	32	224,200
STC	80	15	30	50	210	32	224,200
STC	80	16	30	50	210	32	224,200
STC	80	17	30	50	210	32	224,200
STC	80	18	30	50	210	32	224,200
STC	80	19	30	50	210	32	224,200
STC	80	20	30	50	210	32	224,200
STC	80	22	30	50	210	32	235,100
STC	80	24	30	50	210	32	235,100
STC	80	25	30	50	210	32	235,100
STC	80	26	30	50	210	32	235,100
STC	80	28	30	50	210	32	235,100
STC	80	30	30	50	210	32	235,100
STC	90	3	30	50	220	32	254,900
STC	90	4	30	50	220	32	254,900
STC	90	5	30	50	220	32	254,900
STC	90	6	30	50	220	32	254,900
STC	90	7	30	50	220	32	254,900
STC	90	8	30	50	220	32	254,900
STC	90	9	30	50	220	32	254,900
STC	90	10	30	50	220	32	254,900
STC	90	11	30	50	220	32	267,600
STC	90	12	30	50	220	32	267,600
STC	90	13	30	50	220	32	267,600
STC	90	14	30	50	220	32	267,600
STC	90	15	30	50	220	32	267,600
STC	90	16	30	50	220	32	267,600
STC	90	17	30	50	220	32	267,600
STC	90	18	30	50	220	32	267,600
STC	90	19	30	50	220	32	267,600

型番	刃径 (D)	刃幅 (l)	首径 (d1)	首長 (l1)	全長 (L)	シャンク径 (d)	標準価格
STC	90	20	30	50	220	32	267,600
STC	90	22	30	50	220	32	280,500
STC	90	24	30	50	220	32	280,500
STC	90	25	30	50	220	32	280,500
STC	90	26	30	50	220	32	280,500
STC	90	28	30	50	220	32	280,500
STC	90	30	30	50	220	32	280,500
STC	100	3	30	50	230	32	282,400
STC	100	4	30	50	230	32	282,400
STC	100	5	30	50	230	32	282,400
STC	100	6	30	50	230	32	282,400
STC	100	7	30	50	230	32	282,400
STC	100	8	30	50	230	32	282,400
STC	100	9	30	50	230	32	282,400
STC	100	10	30	50	230	32	282,400
STC	100	11	30	50	230	32	296,800
STC	100	12	30	50	230	32	296,800
STC	100	13	30	50	230	32	296,800
STC	100	14	30	50	230	32	296,800
STC	100	15	30	50	230	32	296,800
STC	100	16	30	50	230	32	296,800
STC	100	17	30	50	230	32	296,800
STC	100	18	30	50	230	32	296,800
STC	100	19	30	50	230	32	296,800
STC	100	20	30	50	230	32	296,800
STC	100	22	30	50	230	32	310,600
STC	100	24	30	50	230	32	310,600
STC	100	25	30	50	230	32	310,600
STC	100	26	30	50	230	32	310,600
STC	100	28	30	50	230	32	310,600
STC	100	30	30	50	230	32	310,600

# (LS-STC) ロングシャンク千鳥刃Tスロットカッター

SINCE 1935  
**F.K.D.**®

T-Slot Cutters, Staggered Tooth, Long Shank

刃径公差  
D ≤ 16   -0.050~-0.160  
16 < D ≤ 30   -0.065~-0.195  
30 < D ≤ 45   -0.080~-0.240  
45 < D ≤ 75   -0.100~-0.290

刃数  
φ 10~22   6枚  
φ 24~42   8枚  
φ 45~50   10枚  
φ 55~60   12枚  
φ 65~70   14枚  
φ 75   16枚

刃幅公差=0~+0.1  
材質=HSS-Co

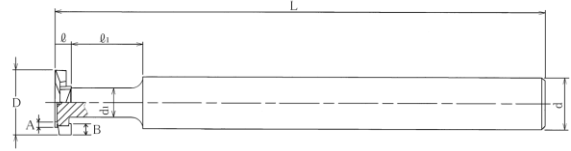
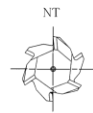

左右振れ角=15° φ ≤ 20  
左右振れ角=12° φ ≥ 21

●注文例=型番、刃径、刃幅、数量「LS-STC 10x3」 ※両サイド刃の長さはP94に掲載。

型番	刃径(D)	刃幅(φ)	首径(d1)	首長(φ1)	全長(L)	シャンク径(d)	標準価格
LS-STC	10	3	4	15	130	10	14,400
LS-STC	10	4	4	15	130	10	14,400
LS-STC	10	5	4	15	130	10	14,400
LS-STC	10	6	4	15	130	10	14,400
LS-STC	10	7	4	15	130	10	14,400
LS-STC	10	8	4	15	130	10	14,400
LS-STC	12	3	5	15	130	10	14,400
LS-STC	12	4	5	15	130	10	14,400
LS-STC	12	5	5	15	130	10	14,400
LS-STC	12	6	5	15	130	10	14,400
LS-STC	12	7	5	15	130	10	14,400
LS-STC	12	8	5	15	130	10	14,400
LS-STC	15	3	6	20	135	12	16,500
LS-STC	15	4	6	20	135	12	16,500
LS-STC	15	5	6	20	135	12	16,500
LS-STC	15	6	6	20	135	12	16,500
LS-STC	15	7	6	20	135	12	16,500
LS-STC	15	8	6	20	135	12	16,500
LS-STC	15	9	6	20	135	12	16,500
LS-STC	15	10	6	20	135	12	16,500
LS-STC	15	11	6	20	135	12	17,600
LS-STC	15	12	6	20	135	12	17,600
LS-STC	16	3	7	20	135	12	17,500
LS-STC	16	4	7	20	135	12	17,500
LS-STC	16	5	7	20	135	12	17,500
LS-STC	16	6	7	20	135	12	17,500
LS-STC	16	7	7	20	135	12	17,500
LS-STC	16	8	7	20	135	12	17,500
LS-STC	16	9	7	20	135	12	17,500
LS-STC	16	10	7	20	135	12	17,500
LS-STC	16	11	7	20	135	12	18,000
LS-STC	16	12	7	20	135	12	18,000
LS-STC	18	3	8	20	150	12	18,600
LS-STC	18	4	8	20	150	12	18,600
LS-STC	18	5	8	20	150	12	18,600
LS-STC	18	6	8	20	150	12	18,600
LS-STC	18	7	8	20	150	12	18,600
LS-STC	18	8	8	20	150	12	18,600
LS-STC	18	9	8	20	150	12	18,600
LS-STC	18	10	8	20	150	12	18,600
LS-STC	18	11	8	20	150	12	19,500
LS-STC	18	12	8	20	150	12	19,500
LS-STC	18	13	8	20	150	12	19,500
LS-STC	18	14	8	20	150	12	19,500
LS-STC	18	15	8	20	150	12	19,500
LS-STC	19	3	8	22	150	12	20,500

型番	刃径(D)	刃幅(φ)	首径(d1)	首長(φ1)	全長(L)	シャンク径(d)	標準価格
LS-STC	19	4	8	22	150	12	20,500
LS-STC	19	5	8	22	150	12	20,500
LS-STC	19	6	8	22	150	12	20,500
LS-STC	19	7	8	22	150	12	20,500
LS-STC	19	8	8	22	150	12	20,500
LS-STC	19	9	8	22	150	12	20,500
LS-STC	19	10	8	22	150	12	20,500
LS-STC	19	11	8	22	150	12	21,700
LS-STC	19	12	8	22	150	12	21,700
LS-STC	20	3	9	22	150	16	20,500
LS-STC	20	4	9	22	150	16	20,500
LS-STC	20	5	9	22	150	16	20,500
LS-STC	20	6	9	22	150	16	20,500
LS-STC	20	7	9	22	150	16	20,500
LS-STC	20	8	9	22	150	16	20,500
LS-STC	20	9	9	22	150	16	20,500
LS-STC	20	10	9	22	150	16	20,500
LS-STC	20	11	9	22	150	16	21,700
LS-STC	20	12	9	22	150	16	21,700
LS-STC	22	3	9.5	22	150	16	23,100
LS-STC	22	4	9.5	22	150	16	23,100
LS-STC	22	5	9.5	22	150	16	23,100
LS-STC	22	6	9.5	22	150	16	23,100
LS-STC	22	7	9.5	22	150	16	23,100
LS-STC	22	8	9.5	22	150	16	23,100
LS-STC	22	9	9.5	22	150	16	23,100
LS-STC	22	10	9.5	22	150	16	23,100
LS-STC	22	11	9.5	22	150	16	24,100
LS-STC	22	12	9.5	22	150	16	24,100
LS-STC	24	3	11	24	150	16	26,300
LS-STC	24	4	11	24	150	16	26,300
LS-STC	24	5	11	24	150	16	26,300
LS-STC	24	6	11	24	150	16	26,300
LS-STC	24	7	11	24	150	16	26,300
LS-STC	24	8	11	24	150	16	26,300
LS-STC	24	9	11	24	150	16	26,300
LS-STC	24	10	11	24	150	16	26,300
LS-STC	24	11	11	24	150	16	27,700
LS-STC	24	12	11	24	150	16	27,700
LS-STC	25	3	11	24	150	16	26,300
LS-STC	25	4	11	24	150	16	26,300
LS-STC	25	5	11	24	150	16	26,300
LS-STC	25	6	11	24	150	16	26,300
LS-STC	25	7	11	24	150	16	26,300
LS-STC	25	8	11	24	150	16	26,300
LS-STC	25	9	11	24	150	16	26,300

# (LS-STC) ロングシャンク千鳥刃Tスロットカッター

SINCE 1935  
**F.K.D.**®

T-Slot Cutters, Staggered Tooth, Long Shank

刃径公差  
D ≤ 16 -0.050 ~ -0.160  
16 < D ≤ 30 -0.065 ~ -0.195  
30 < D ≤ 45 -0.080 ~ -0.240  
45 < D ≤ 75 -0.100 ~ -0.290

刃数  
φ 10 ~ 22 6枚  
φ 24 ~ 42 8枚  
φ 45 ~ 50 10枚  
φ 55 ~ 60 12枚  
φ 65 ~ 70 14枚  
φ 75 16枚

刃幅公差 = 0 ~ +0.1  
材質 = HSS-Co

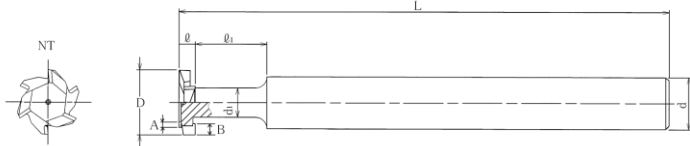

左右振れ角 = 15° φ ≤ 20  
左右振れ角 = 12° φ ≥ 21

●注用例 = 型番、刃径、刃幅、数量 「LS-STC 25x10」 ※両サイド刃の長さはP94に掲載。

型番	刃径 (D)	刃幅 (φ)	首径 (d1)	首長 (φ1)	全長 (L)	シャンク径 (d)	標準価格
LS-STC	25	10	11	24	150	16	26,300
LS-STC	25	11	11	24	150	16	27,700
LS-STC	25	12	11	24	150	16	27,700
LS-STC	25	13	11	24	150	16	27,700
LS-STC	25	14	11	24	150	16	27,700
LS-STC	25	15	11	24	150	16	27,700
LS-STC	25	16	11	24	150	16	27,700
LS-STC	28	3	12	25	150	16	31,900
LS-STC	28	4	12	25	150	16	31,900
LS-STC	28	5	12	25	150	16	31,900
LS-STC	28	6	12	25	150	16	31,900
LS-STC	28	7	12	25	150	16	31,900
LS-STC	28	8	12	25	150	16	31,900
LS-STC	28	9	12	25	150	16	31,900
LS-STC	28	10	12	25	150	16	31,900
LS-STC	28	11	12	25	150	16	33,700
LS-STC	28	12	12	25	150	16	33,700
LS-STC	28	13	12	25	150	16	33,700
LS-STC	28	14	12	25	150	16	33,700
LS-STC	28	15	12	25	150	16	33,700
LS-STC	28	16	12	25	150	16	33,700
LS-STC	30	3	13	26	150	16	37,400
LS-STC	30	4	13	26	150	16	37,400
LS-STC	30	5	13	26	150	16	37,400
LS-STC	30	6	13	26	150	16	37,400
LS-STC	30	7	13	26	150	16	37,400
LS-STC	30	8	13	26	150	16	37,400
LS-STC	30	9	13	26	150	16	37,400
LS-STC	30	10	13	26	150	16	37,400
LS-STC	30	11	13	26	150	16	39,100
LS-STC	30	12	13	26	150	16	39,100
LS-STC	30	13	13	26	150	16	39,100
LS-STC	30	14	13	26	150	16	39,100
LS-STC	30	15	13	26	150	16	39,100
LS-STC	30	16	13	26	150	16	39,100
LS-STC	32	3	15	28	150	16	40,200
LS-STC	32	4	15	28	150	16	40,200
LS-STC	32	5	15	28	150	16	40,200
LS-STC	32	6	15	28	150	16	40,200
LS-STC	32	7	15	28	150	16	40,200
LS-STC	32	8	15	28	150	16	40,200
LS-STC	32	9	15	28	150	16	40,200
LS-STC	32	10	15	28	150	16	40,200
LS-STC	32	11	15	28	150	16	42,200
LS-STC	32	12	15	28	150	16	42,200
LS-STC	32	13	15	28	150	16	42,200

型番	刃径 (D)	刃幅 (φ)	首径 (d1)	首長 (φ1)	全長 (L)	シャンク径 (d)	標準価格
LS-STC	32	14	15	28	150	16	42,200
LS-STC	32	15	15	28	150	16	42,200
LS-STC	32	16	15	28	150	16	42,200
LS-STC	32	17	15	28	150	16	42,200
LS-STC	32	18	15	28	150	16	42,200
LS-STC	32	19	15	28	150	16	42,200
LS-STC	32	20	15	28	150	16	42,200
LS-STC	35	3	15	28	150	16	43,000
LS-STC	35	4	15	28	150	16	43,000
LS-STC	35	5	15	28	150	16	43,000
LS-STC	35	6	15	28	150	16	43,000
LS-STC	35	7	15	28	150	16	43,000
LS-STC	35	8	15	28	150	16	43,000
LS-STC	35	9	15	28	150	16	43,000
LS-STC	35	10	15	28	150	16	43,000
LS-STC	35	11	15	28	150	16	45,400
LS-STC	35	12	15	28	150	16	45,400
LS-STC	35	13	15	28	150	16	45,400
LS-STC	35	14	15	28	150	16	45,400
LS-STC	35	15	15	28	150	16	45,400
LS-STC	35	16	15	28	150	16	45,400
LS-STC	35	17	15	28	150	16	45,400
LS-STC	35	18	15	28	150	16	45,400
LS-STC	35	19	15	28	150	16	45,400
LS-STC	35	20	15	28	150	16	45,400
LS-STC	38	3	18	34	180	20	51,600
LS-STC	38	4	18	34	180	20	51,600
LS-STC	38	5	18	34	180	20	51,600
LS-STC	38	6	18	34	180	20	51,600
LS-STC	38	7	18	34	180	20	51,600
LS-STC	38	8	18	34	180	20	51,600
LS-STC	38	9	18	34	180	20	51,600
LS-STC	38	10	18	34	180	20	51,600
LS-STC	38	11	18	34	180	20	54,500
LS-STC	38	12	18	34	180	20	54,500
LS-STC	38	13	18	34	180	20	54,500
LS-STC	38	14	18	34	180	20	54,500
LS-STC	38	15	18	34	180	20	54,500
LS-STC	38	16	18	34	180	20	54,500
LS-STC	38	17	18	34	180	20	54,500
LS-STC	38	18	18	34	180	20	54,500
LS-STC	38	19	18	34	180	20	54,500
LS-STC	38	20	18	34	180	20	54,500
LS-STC	40	3	19	34	180	20	62,200
LS-STC	40	4	19	34	180	20	62,200
LS-STC	40	5	19	34	180	20	62,200

# (LS-STC) ロングシャンク千鳥刃Tスロットカッター

SINCE 1935  
**F.K.D.**®

T-Slot Cutters, Staggered Tooth, Long Shank

刃径公差  
 $D \leq 16$   $-0.050 \sim -0.160$   
 $16 < D \leq 30$   $-0.065 \sim -0.195$   
 $30 < D \leq 45$   $-0.080 \sim -0.240$   
 $45 < D \leq 75$   $-0.100 \sim -0.290$

刃数  
 $\phi 10 \sim 22$  6枚  
 $\phi 24 \sim 42$  8枚  
 $\phi 45 \sim 50$  10枚  
 $\phi 55 \sim 60$  12枚  
 $\phi 65 \sim 70$  14枚  
 $\phi 75$  16枚

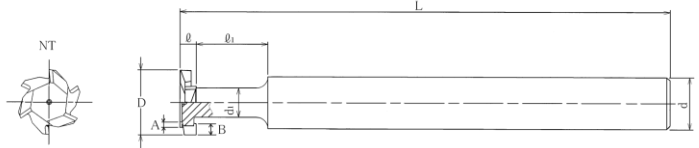

左右傾れ角 = 15°  $\phi \leq 20$   
 左右傾れ角 = 12°  $\phi \geq 21$

刃幅公差 = 0 ~ +0.1  
 材質 = HSS-Co

●注用例 = 型番、刃径、刃幅、数量「LS-STC 40x6」 ※両サイド刃の長さはP94に掲載。

型番	刃径 (D)	刃幅 (ℓ)	首径 (d1)	首長 (ℓ1)	全長 (L)	シャンク径 (d)	標準価格
LS-STC	40	6	19	34	180	20	62,200
LS-STC	40	7	19	34	180	20	62,200
LS-STC	40	8	19	34	180	20	62,200
LS-STC	40	9	19	34	180	20	62,200
LS-STC	40	10	19	34	180	20	62,200
LS-STC	40	11	19	34	180	20	65,000
LS-STC	40	12	19	34	180	20	65,000
LS-STC	40	13	19	34	180	20	65,000
LS-STC	40	14	19	34	180	20	65,000
LS-STC	40	15	19	34	180	20	65,000
LS-STC	40	16	19	34	180	20	65,000
LS-STC	40	17	19	34	180	20	65,000
LS-STC	40	18	19	34	180	20	65,000
LS-STC	40	19	19	34	180	20	65,000
LS-STC	40	20	19	34	180	20	65,000
LS-STC	42	3	20	38	200	25	79,400
LS-STC	42	4	20	38	200	25	79,400
LS-STC	42	5	20	38	200	25	79,400
LS-STC	42	6	20	38	200	25	79,400
LS-STC	42	7	20	38	200	25	79,400
LS-STC	42	8	20	38	200	25	79,400
LS-STC	42	9	20	38	200	25	79,400
LS-STC	42	10	20	38	200	25	79,400
LS-STC	42	11	20	38	200	25	83,300
LS-STC	42	12	20	38	200	25	83,300
LS-STC	42	13	20	38	200	25	83,300
LS-STC	42	14	20	38	200	25	83,300
LS-STC	42	15	20	38	200	25	83,300
LS-STC	42	16	20	38	200	25	83,300
LS-STC	42	18	20	38	200	25	83,300
LS-STC	42	20	20	38	200	25	83,300
LS-STC	45	3	20	38	200	25	79,400
LS-STC	45	4	20	38	200	25	79,400
LS-STC	45	5	20	38	200	25	79,400
LS-STC	45	6	20	38	200	25	79,400
LS-STC	45	7	20	38	200	25	79,400
LS-STC	45	8	20	38	200	25	79,400
LS-STC	45	9	20	38	200	25	79,400
LS-STC	45	10	20	38	200	25	79,400
LS-STC	45	12	20	38	200	25	83,300
LS-STC	45	14	20	38	200	25	83,300
LS-STC	45	15	20	38	200	25	83,300
LS-STC	45	16	20	38	200	25	83,300
LS-STC	45	18	20	38	200	25	83,300
LS-STC	45	20	20	38	200	25	83,300
LS-STC	48	3	20	40	200	25	86,100

型番	刃径 (D)	刃幅 (ℓ)	首径 (d1)	首長 (ℓ1)	全長 (L)	シャンク径 (d)	標準価格
LS-STC	48	4	20	40	200	25	86,100
LS-STC	48	5	20	40	200	25	86,100
LS-STC	48	6	20	40	200	25	86,100
LS-STC	48	7	20	40	200	25	86,100
LS-STC	48	8	20	40	200	25	86,100
LS-STC	48	9	20	40	200	25	86,100
LS-STC	48	10	20	40	200	25	86,100
LS-STC	48	12	20	40	200	25	90,500
LS-STC	48	14	20	40	200	25	90,500
LS-STC	48	15	20	40	200	25	90,500
LS-STC	48	16	20	40	200	25	90,500
LS-STC	48	18	20	40	200	25	90,500
LS-STC	48	20	20	40	200	25	90,500
LS-STC	50	3	20	40	200	25	86,100
LS-STC	50	4	20	40	200	25	86,100
LS-STC	50	5	20	40	200	25	86,100
LS-STC	50	6	20	40	200	25	86,100
LS-STC	50	7	20	40	200	25	86,100
LS-STC	50	8	20	40	200	25	86,100
LS-STC	50	9	20	40	200	25	86,100
LS-STC	50	10	20	40	200	25	86,100
LS-STC	50	12	20	40	200	25	90,500
LS-STC	50	14	20	40	200	25	90,500
LS-STC	50	15	20	40	200	25	90,500
LS-STC	50	16	20	40	200	25	90,500
LS-STC	50	18	20	40	200	25	90,500
LS-STC	50	20	20	40	200	25	90,500
LS-STC	55	3	20	45	200	25	103,500
LS-STC	55	4	20	45	200	25	103,500
LS-STC	55	5	20	45	200	25	103,500
LS-STC	55	6	20	45	200	25	103,500
LS-STC	55	7	20	45	200	25	103,500
LS-STC	55	8	20	45	200	25	103,500
LS-STC	55	9	20	45	200	25	103,500
LS-STC	55	10	20	45	200	25	103,500
LS-STC	55	12	20	45	200	25	108,600
LS-STC	55	14	20	45	200	25	108,600
LS-STC	55	15	20	45	200	25	108,600
LS-STC	55	16	20	45	200	25	108,600
LS-STC	55	18	20	45	200	25	108,600
LS-STC	55	20	20	45	200	25	108,600
LS-STC	55	25	20	45	200	25	113,700
LS-STC	60	3	23	50	200	25	127,600
LS-STC	60	4	23	50	200	25	127,600
LS-STC	60	5	23	50	200	25	127,600
LS-STC	60	6	23	50	200	25	127,600

# (LS-STC) ロングシャンク千鳥刃Tスロットカッター

SINCE 1935  
**F.K.D.**®

T-Slot Cutters, Staggered Tooth, Long Shank

刃径公差  
 $D \leq 16$   $-0.050 \sim -0.160$   
 $16 < D \leq 30$   $-0.065 \sim -0.195$   
 $30 < D \leq 45$   $-0.080 \sim -0.240$   
 $45 < D \leq 75$   $-0.100 \sim -0.290$

刃数  
 $\phi 10 \sim 22$  6枚  
 $\phi 24 \sim 42$  8枚  
 $\phi 45 \sim 50$  10枚  
 $\phi 55 \sim 60$  12枚  
 $\phi 65 \sim 70$  14枚  
 $\phi 75$  16枚

刃幅公差 =  $0 \sim +0.1$   
 材質 = HSS-Co

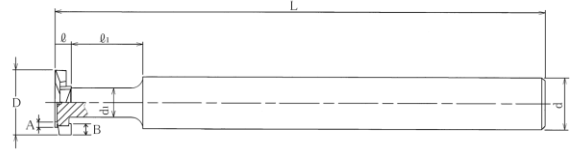
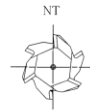

左右振れ角 =  $15^\circ$   $\varnothing \leq 20$   
 左右振れ角 =  $12^\circ$   $\varnothing \geq 21$

●注文例 = 型番、刃径、刃幅、数量 「LS-STC 60x7」 ※両サイド刃の長さはP94に掲載。

型番	刃径 (D)	刃幅 (ℓ)	首径 (d1)	首長 (ℓ1)	全長 (L)	シャンク径 (d)	標準価格
LS-STC	60	7	23	50	200	25	127,600
LS-STC	60	8	23	50	200	25	127,600
LS-STC	60	9	23	50	200	25	127,600
LS-STC	60	10	23	50	200	25	127,600
LS-STC	60	12	23	50	200	25	134,000
LS-STC	60	14	23	50	200	25	134,000
LS-STC	60	15	23	50	200	25	134,000
LS-STC	60	16	23	50	200	25	134,000
LS-STC	60	18	23	50	200	25	134,000
LS-STC	60	20	23	50	200	25	134,000
LS-STC	60	22	23	50	200	25	140,300
LS-STC	60	24	23	50	200	25	140,300
LS-STC	60	25	23	50	200	25	140,300
LS-STC	65	5	23	50	220	25	146,500
LS-STC	65	6	23	50	220	25	146,500
LS-STC	65	7	23	50	220	25	146,500
LS-STC	65	8	23	50	220	25	146,500
LS-STC	65	9	23	50	220	25	146,500
LS-STC	65	10	23	50	220	25	146,500
LS-STC	65	12	23	50	220	25	154,000
LS-STC	65	14	23	50	220	25	154,000
LS-STC	65	15	23	50	220	25	154,000
LS-STC	65	16	23	50	220	25	154,000
LS-STC	65	18	23	50	220	25	154,000
LS-STC	65	20	23	50	220	25	154,000
LS-STC	65	22	23	50	220	25	161,000
LS-STC	65	24	23	50	220	25	161,000
LS-STC	65	25	23	50	220	25	161,000
LS-STC	70	5	23	50	220	25	168,900

型番	刃径 (D)	刃幅 (ℓ)	首径 (d1)	首長 (ℓ1)	全長 (L)	シャンク径 (d)	標準価格
LS-STC	70	6	23	50	220	25	168,900
LS-STC	70	7	23	50	220	25	168,900
LS-STC	70	8	23	50	220	25	168,900
LS-STC	70	9	23	50	220	25	168,900
LS-STC	70	10	23	50	220	25	168,900
LS-STC	70	12	23	50	220	25	177,200
LS-STC	70	14	23	50	220	25	177,200
LS-STC	70	15	23	50	220	25	177,200
LS-STC	70	16	23	50	220	25	177,200
LS-STC	70	18	23	50	220	25	177,200
LS-STC	70	20	23	50	220	25	177,200
LS-STC	70	22	23	50	220	25	185,800
LS-STC	70	24	23	50	220	25	185,800
LS-STC	70	25	23	50	220	25	185,800
LS-STC	75	5	30	50	230	32	189,400
LS-STC	75	6	30	50	230	32	189,400
LS-STC	75	7	30	50	230	32	189,400
LS-STC	75	8	30	50	230	32	189,400
LS-STC	75	9	30	50	230	32	189,400
LS-STC	75	10	30	50	230	32	189,400
LS-STC	75	12	30	50	230	32	199,000
LS-STC	75	14	30	50	230	32	199,000
LS-STC	75	15	30	50	230	32	199,000
LS-STC	75	16	30	50	230	32	199,000
LS-STC	75	18	30	50	230	32	199,000
LS-STC	75	20	30	50	230	32	199,000
LS-STC	75	22	30	50	230	32	208,300
LS-STC	75	24	30	50	230	32	208,300
LS-STC	75	25	30	50	230	32	208,300



### Tスロットカッター

TC		
刃径	A	B
8	2	1.5
9	2	1.5
10	2	1.5
12	2.5	1.5
13	2.5	2
14	2.5	2
15	3	2.5
16	3	2.5
18	3	2.5
19	3.5	3
20	3.5	3
22	4	3
24	4.5	3.5
25	4.5	3.5
26	5	4
28	5.5	4
30	6	5
32	6.5	5
35	7.5	5.5
36	7.5	6
38	8	7
40	8	6
42	8	6
45	8.5	7
48	9.5	8
50	10	8.5
55	11	9.5
60	11	9
65	11	11
70	11	11
75	11	11
80	12	12
90	13	13
100	14	14

LS-TC		
刃径	A	B
10	2	1.5
12	2.5	1.5
15	3	2.5
20	3.5	3
25	4.5	3.5
30	6	4
35	7.5	5.5
40	8	6
45	8.5	7
50	10	8.5

### 千鳥刃Tスロットカッター

STC		
刃径	A	B
10	2.5	2
12	2.5	2
13	3	2.5
15	3.5	3
16	3	3
18	3.5	3
19	3.5	3
20	4	3.5
22	4.5	4
24	4.5	3.5
25	5	4
26	5.5	4.5
28	6	5
30	6	5
32	6.5	5.5
35	7	6
36	7.5	6.5
38	7.5	6.5
40	8	7
42	8.5	7.5
45	9	8
48	9.5	8.5
50	10	9
55	11	9.5
60	11	11
65	11	11
70	11	11
75	11	11
80	12	12
90	13	13
100	14	14

LS-STC		
刃径	A	B
10	2.5	2
12	2.5	2
15	3.5	3
16	3.5	3
18	4	3.5
19	4	3.5
20	4	3.5
22	4.5	4
24	5	4
25	5	4
28	5.5	4.5
30	6	5
32	6.5	5.5
35	7	6
38	7.5	6.5
40	8	7
42	8.5	7.5
45	9	8
48	9.5	8.5
50	10	9
55	11	9.5
60	11	11
65	11	11
70	11	11
75	11	11

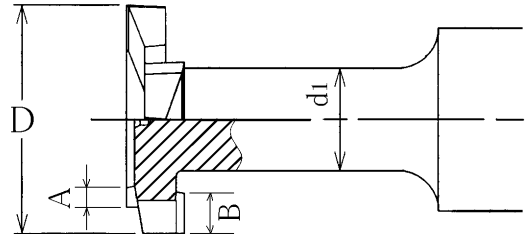
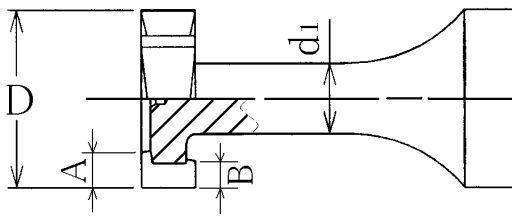

(TSE)  
Tスロットエンドミル  
T-Slot End Mills

SINCE 1935  
F.K.D.®

材質=HSS-Co  
刃数=5枚  
リード角=右振れ30°  
刃径公差=0~+0.05  
刃幅公差=0~+0.1

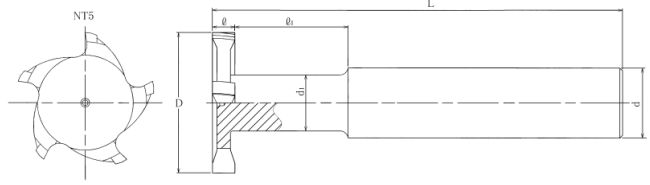

●注文例=型番、刃径、刃幅、数量「TSE 15x5」

型番	刃径 (D)	刃幅 (Ø)	首径 (d1)	首長 (Ø1)	全長 (L)	シャンク径 (d)	標準価格
TSE	15	5	6	20	115	16	16,300
TSE	15	6	6	20	115	16	16,300
TSE	15	7	6	20	115	16	16,300
TSE	15	8	6	20	115	16	16,300
TSE	15	10	6	20	115	16	16,300
TSE	16	5	7	20	115	16	16,800
TSE	16	6	7	20	115	16	16,800
TSE	16	7	7	20	115	16	16,800
TSE	16	8	7	20	115	16	16,800
TSE	16	10	7	20	115	16	16,800
TSE	18	5	8	22	120	16	18,500
TSE	18	6	8	22	120	16	18,500
TSE	18	7	8	22	120	16	18,500
TSE	18	8	8	22	120	16	18,500
TSE	18	10	8	22	120	16	18,500
TSE	19	5	9	22	120	16	20,200
TSE	19	6	9	22	120	16	20,200
TSE	19	7	9	22	120	16	20,200
TSE	19	8	9	22	120	16	20,200
TSE	19	10	9	22	120	16	20,200
TSE	20	5	9	22	120	16	20,200
TSE	20	6	9	22	120	16	20,200
TSE	20	7	9	22	120	16	20,200
TSE	20	8	9	22	120	16	20,200
TSE	20	10	9	22	120	16	20,200
TSE	22	5	9.5	22	120	16	22,400
TSE	22	6	9.5	22	120	16	22,400
TSE	22	7	9.5	22	120	16	22,400
TSE	22	8	9.5	22	120	16	22,400
TSE	22	10	9.5	22	120	16	22,400
TSE	22	12	9.5	22	120	16	23,700
TSE	24	5	10	24	125	16	26,300
TSE	24	6	10	24	125	16	26,300
TSE	24	7	10	24	125	16	26,300
TSE	24	8	10	24	125	16	26,300
TSE	24	10	10	24	125	16	26,300
TSE	24	12	10	24	125	16	27,500
TSE	25	5	11	24	125	16	26,300
TSE	25	6	11	24	125	16	26,300
TSE	25	7	11	24	125	16	26,300
TSE	25	8	11	24	125	16	26,300
TSE	25	10	11	24	125	16	26,300
TSE	25	12	11	24	125	16	27,500
TSE	25	15	11	24	125	16	27,500
TSE	26	5	11	24	125	16	31,200
TSE	26	6	11	24	125	16	31,200

型番	刃径 (D)	刃幅 (Ø)	首径 (d1)	首長 (Ø1)	全長 (L)	シャンク径 (d)	標準価格
TSE	26	7	11	24	125	16	31,200
TSE	26	8	11	24	125	16	31,200
TSE	26	10	11	24	125	16	31,200
TSE	26	12	11	24	125	16	32,900
TSE	26	15	11	24	125	16	32,900
TSE	28	5	11	24	125	16	31,200
TSE	28	6	11	24	125	16	31,200
TSE	28	7	11	24	125	16	31,200
TSE	28	8	11	24	125	16	31,200
TSE	28	10	11	24	125	16	31,200
TSE	28	12	11	24	125	16	32,900
TSE	28	15	11	24	125	16	32,900
TSE	30	5	13	26	125	20	36,400
TSE	30	6	13	26	125	20	36,400
TSE	30	7	13	26	125	20	36,400
TSE	30	8	13	26	125	20	36,400
TSE	30	10	13	26	125	20	36,400
TSE	30	12	13	26	125	20	38,100
TSE	30	15	13	26	125	20	38,100
TSE	32	7	15	28	130	20	39,500
TSE	32	8	15	28	130	20	39,500
TSE	32	10	15	28	130	20	39,500
TSE	32	12	15	28	130	20	41,500
TSE	32	15	15	28	130	20	41,500
TSE	32	16	15	28	130	20	41,500
TSE	32	18	15	28	130	20	41,500
TSE	32	20	15	28	130	20	41,500
TSE	35	7	17	28	130	20	41,500
TSE	35	8	17	28	130	20	41,500
TSE	35	10	17	28	130	20	41,500
TSE	35	12	17	28	130	20	43,200
TSE	35	15	17	28	130	20	43,200
TSE	35	16	17	28	130	20	43,200
TSE	35	18	17	28	130	20	43,200
TSE	35	20	17	28	130	20	43,200
TSE	38	7	18	34	135	25	50,700
TSE	38	8	18	34	135	25	50,700
TSE	38	10	18	34	135	25	50,700
TSE	38	12	18	34	135	25	53,200
TSE	38	15	18	34	135	25	53,200
TSE	38	16	18	34	135	25	53,200
TSE	38	18	18	34	135	25	53,200
TSE	38	20	18	34	135	25	53,200
TSE	40	7	19	34	135	25	60,400
TSE	40	8	19	34	135	25	60,400
TSE	40	10	19	34	135	25	60,400

# (TSE) Tスロットエンドミル

T-Slot End Mills



材質=HSS-Co  
 刃数=5枚  
 リード角=右振り30°  
 刃径公差=0~+0.05  
 刃幅公差=0~+0.1

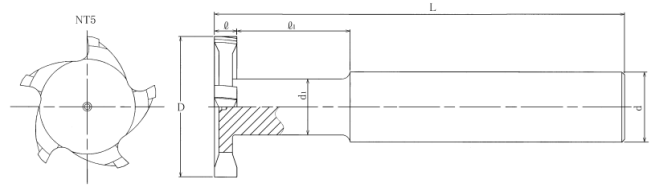

●注文例=型番、刃径、刃幅、数量「TSE 40x12」

型番	刃径 (D)	刃幅 (Ø)	首径 (d1)	首長 (Ø1)	全長 (L)	シャンク径 (d)	標準価格
TSE	40	12	19	34	135	25	63,300
TSE	40	15	19	34	135	25	63,300
TSE	40	16	19	34	135	25	63,300
TSE	40	18	19	34	135	25	63,300
TSE	40	20	19	34	135	25	63,300
TSE	45	8	20	38	140	25	77,200
TSE	45	10	20	38	140	25	77,200
TSE	45	12	20	38	140	25	80,900
TSE	45	15	20	38	140	25	80,900
TSE	45	16	20	38	140	25	80,900
TSE	45	18	20	38	140	25	80,900
TSE	45	20	20	38	140	25	80,900
TSE	45	22	20	38	140	25	84,600
TSE	45	25	20	38	140	25	84,600
TSE	50	8	20	40	145	25	84,600
TSE	50	10	20	40	145	25	84,600
TSE	50	12	20	40	145	25	88,800
TSE	50	15	20	40	145	25	88,800
TSE	50	16	20	40	145	25	88,800
TSE	50	18	20	40	145	25	88,800
TSE	50	20	20	40	145	25	88,800

型番	刃径 (D)	刃幅 (Ø)	首径 (d1)	首長 (Ø1)	全長 (L)	シャンク径 (d)	標準価格
TSE	50	22	20	40	145	25	93,100
TSE	50	25	20	40	145	25	93,100
TSE	50	30	20	40	145	25	93,100
TSE	55	10	20	42	155	25	100,900
TSE	55	12	20	42	155	25	105,900
TSE	55	15	20	42	155	25	105,900
TSE	55	16	20	42	155	25	105,900
TSE	55	18	20	42	155	25	105,900
TSE	55	20	20	42	155	25	105,900
TSE	55	22	20	42	155	25	111,000
TSE	55	25	20	42	155	25	111,000
TSE	55	30	20	42	155	25	111,000
TSE	60	10	23	45	170	25	124,100
TSE	60	12	23	45	170	25	130,100
TSE	60	15	23	45	170	25	130,100
TSE	60	16	23	45	170	25	130,100
TSE	60	18	23	45	170	25	130,100
TSE	60	20	23	45	170	25	130,100
TSE	60	22	23	45	170	25	136,500
TSE	60	25	23	45	170	25	136,500
TSE	60	30	23	45	170	25	136,500

# (SAC) 柄付アングルカッター

SINCE 1935  
**F.K.D.**®

Dovetail Cutters

材質=HSS

刃数

φ10~12 6枚 φ65 14枚  
φ15~25 8枚 φ70 16枚  
φ30~45 10枚 φ75 18枚  
φ50~60 12枚 φ80~100 20枚

刃径公差=0~+0.5

角度公差=±15'

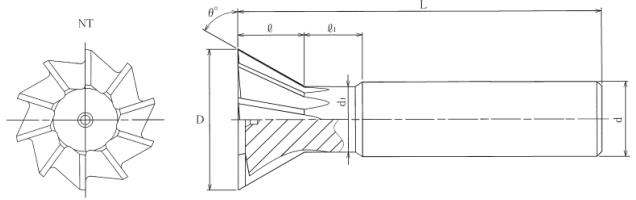

●注文例=型番、角度、刃径、数量 「SAC 30°x10」

型番	角度 (θ°)	刃径 (D)	刃幅 (φ)	首径 (d1)	首長 (l1)	全長 (L)	シャンク径 (d)	標準価格
SAC	30°	10	2	3	7	50	8	11,400
		12	2.3	4	9.7	52	8	11,400
		15	2.6	6	8.4	59	10	11,400
		20	3.8	7	10.2	64	10	15,200
		25	4.6	9	13.4	68	12	19,500
		30	5.2	12	16.8	76	16	21,600
		35	6.4	13	20.6	82	16	31,100
		40	7	16	23	90	20	38,100
		45	8.4	16	26.6	96	20	52,600
		50	9.3	18	30.7	105	25	62,200
		55	10	20	32.9	110	25	76,700
		60	11.6	20	35.4	115	25	82,900
SAC	45°	10	3	4	8	50	8	10,300
		12	3.5	5	8.5	52	8	10,300
		15	4	7	10	59	10	10,300
		20	6	8	13	64	10	13,800
		25	7.5	10	15.5	68	12	17,700
		30	8	14	18	76	16	19,500
		35	10	15	22	82	16	28,200
		40	11	18	24	90	20	34,500
		45	13.5	18	27.5	96	20	47,900
		50	15	20	30	105	25	56,400
		55	16.5	22	33.5	110	25	69,600
		60	19	22	36	115	25	75,400
		65	20.5	24	39.5	130	25	115,700
		70	23	24	42	140	25	126,000
		75	23.5	28	46.5	150	32	148,400
		80	25	30	55	160	32	165,400
90	27.5	35	52.5	160	42	212,400		
100	30	40	55	170	42	276,100		
SAC	50°	10	3.5	4	8.5	50	8	11,400
		12	4.2	5	7.8	52	8	11,400
		15	4.8	7	9.2	59	10	11,400
		20	7.1	8	11.9	64	10	15,200
		25	9	10	14	68	12	19,500
		30	9.5	14	16.5	76	16	21,600
		35	12	15	20	82	16	31,100
		40	13.1	18	21.9	90	20	38,100
		45	16	18	25	96	20	52,600
		50	17.8	20	27.2	105	25	62,200
		55	19.6	22	30.4	110	25	76,700
		60	22.6	22	32.4	115	25	82,900
SAC	60°	10	5.2	4	7.8	50	8	9,600
		12	6	5	6	52	8	10,000
		15	6.9	7	7.1	59	10	10,300
		20	10.4	8	8.6	64	10	13,800
		25	13	10	10	68	12	17,700
		30	13.8	14	12.2	76	16	19,500

型番	角度 (θ°)	刃径 (D)	刃幅 (φ)	首径 (d1)	首長 (l1)	全長 (L)	シャンク径 (d)	標準価格
SAC	60°	35	17.3	15	14.7	82	16	28,200
		40	19	18	16	90	20	34,500
		45	23.4	18	17.6	96	20	47,900
		50	26	20	19	105	25	56,400
		55	28.6	22	21.4	110	25	69,600
		60	32.9	22	22.1	115	25	75,400
		65	32.9	27	27.1	130	32	115,700
		70	36.4	28	28.6	140	32	126,000
		75	39	30	31	150	32	148,400
		80	43.3	30	36.7	160	32	165,400
		90	43.3	40	36.7	160	42	212,400
		100	52	40	33	170	42	276,100
		SAC	70°	10	5.5	4	7.5	50
12	6			5	6	52	8	11,400
15	7			7	7	59	10	11,400
20	10			8	9	64	10	15,200
25	13			10	10	68	12	19,500
30	16			14	10	76	16	21,600
35	20			15	12	82	16	31,100
40	23			18	12	90	20	38,100
45	26			18	15	96	20	52,600
50	30			20	15	105	25	62,200
55	32			22	18	110	25	76,700
60	35			22	20	115	25	82,900
SAC	75°	10	5.5	4	5.5	50	8	11,400
		12	6	5	6	52	8	11,400
		15	7	7	7	59	10	11,400
		20	11	8	8	64	10	15,200
		25	13	10	10	68	12	19,500
		30	16	14	10	76	16	21,600
		35	20	15	12	82	16	31,100
		40	23	18	12	90	20	38,100
		45	26	18	15	96	20	52,600
		50	30	20	15	105	25	62,200
		55	32	22	18	110	25	76,700
		60	35	22	20	115	25	82,900
SAC	80°	10	5.5	4	7.5	50	8	11,400
		12	6	5	6	52	8	11,400
		15	8	7	6	59	10	11,400
		20	12	8	7	64	10	15,200
		25	13	10	10	68	12	19,500
		30	16	14	10	76	16	21,600
		35	20	15	12	82	16	31,100
		40	23	18	12	90	20	38,100
		45	26	18	15	96	20	52,600
		50	30	20	15	105	25	62,200
		55	32	22	18	110	25	76,700
		60	35	22	20	115	25	82,900

# (SWC) 柄付ダブルアングルカッター

Double Angle Cutters

SINCE 1935  
F.K.D.®

材質=HSS

刃数

刃径公差=0~+1

角度公差=±15'

φ10 8枚  
φ15~25 10枚  
φ30~35 12枚  
φ40~45 14枚  
φ50 16枚  
φ60 18枚

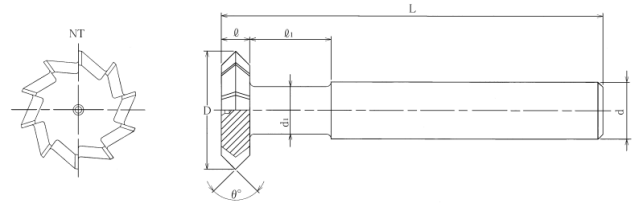

●注文例=型番、角度、刃径、数量「SWC 60°x15」

型番	角度 (θ°)	刃径 (D)	刃幅 (φ)	首径 (d1)	首長 (l1)	全長 (L)	シャンク径 (d)	標準価格
SWC	60°	15	4	8	17	70	10	11,200
		20	5	8	17	80	12	15,200
		25	6	10	17	80	12	18,500
		30	8	14	18	85	16	22,000
		35	10	14	18	90	16	30,900
		40	12	16	20	95	20	38,100
		45	16	16	20	100	20	50,700
		50	18	18	22	110	25	63,300
		60	20	20	24	120	25	86,000
SWC	90°	10	3	4	10	55	6	10,000
		15	4	8	17	70	10	11,200
		20	5	8	17	80	12	15,200
		25	6	10	17	80	12	18,500
		30	8	14	18	85	16	22,000
		35	10	14	18	90	16	30,900
		40	12	16	20	95	20	38,100
		45	16	16	20	100	20	50,700
		50	18	18	22	110	25	63,300
60	20	20	24	120	25	86,000		

型番	角度 (θ°)	刃径 (D)	刃幅 (φ)	首径 (d1)	首長 (l1)	全長 (L)	シャンク径 (d)	標準価格
SWC	120°	10	3	4	10	55	6	10,000
		15	5	8	17	70	10	11,200
		20	5	8	17	80	12	15,200
		25	6	10	17	80	12	18,500
		30	8	14	18	85	16	22,000
		35	10	14	18	90	16	30,900
		40	12	16	20	95	20	38,100
		45	16	16	20	100	20	50,700
		50	18	18	22	110	25	63,300
60	20	20	24	120	25	86,000		

# (SPC) 柄付傘型カッター

Face Angle Cutters

材質=HSS

刃数

太径公差=0~+0.5

角度公差=±15'

φ15~25 8枚  
φ30~40 10枚  
φ45~60 12枚  
φ65~80 14枚

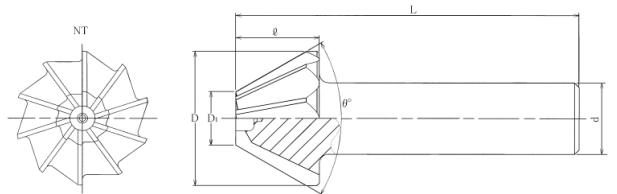

●注文例=型番、角度、刃径、数量「SPC 60°x15」

型番	角度 (θ°)	太径 (D)	小径 (D1)	刃長 (φ)	全長 (L)	シャンク径 (d)	標準価格
SPC	両角 60°	15	6	11	59	8	12,900
		20	8	13.5	64	10	16,800
		25	10	16	68	12	20,000
		30	12	18.5	76	16	24,200
		35	14	23	82	16	34,200
		40	16	26	90	25	41,800
		45	18	28	96	25	55,300
		50	20	31	105	32	69,600
		60	24	36	115	32	94,900
		65	26	40	130	32	105,200
		70	28	42	140	32	113,600
		75	30	45	150	32	134,000
		80	32	48	160	32	149,100

型番	角度 (θ°)	太径 (D)	小径 (D1)	刃長 (φ)	全長 (L)	シャンク径 (d)	標準価格
SPC	両角 90°	15	6	8	59	8	12,900
		20	8	9	64	10	16,800
		25	10	10.5	68	12	20,000
		30	12	12	76	16	24,200
		35	14	15	82	16	34,200
		40	16	17	90	25	41,800
		45	18	19	96	25	55,300
		50	20	20	105	32	69,600
		60	24	23	115	32	94,900
		65	26	26	115	32	105,200
		70	28	27	125	32	113,600
		75	30	29	130	32	134,000
		80	32	30	140	32	149,100

# (CR) センターリーマ Center Reamers

SINCE 1935  
**F.K.D.**®

材質=HSS

太径公差=+0.2~+0.6

角度公差=±15'

刃数

φ 6~ 8 5枚

φ 10~20 7枚

φ 25~50 9枚

φ 60 11枚

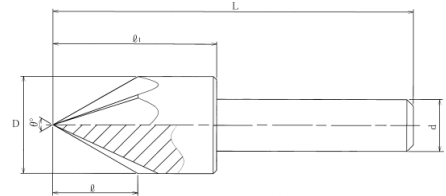

●注文例=型番、角度、太径、数量「CR 60°x6」

型番	角度 (θ°)	小径	太径 (D)	外径長 (ℓ1)	刃長 (ℓ)	全長 (L)	シャンク径 (d)	標準価格
CR	60°	トンガリセンター	6	13	5.2	43	6	3,100
			8	18	6.93	48	6	3,500
			10	18	8.66	48	6	4,800
			12	25	10.39	55	8	5,200
			16	25	13.86	55	10	7,000
			20	25	17.32	55	10	7,700
			25	35	21.65	70	12	10,700
			30	38	25.98	73	12	13,800
			35	43	30.31	80	12	24,400
			40	45	34.64	85	12	32,800
			45	48	38.97	88	12	45,300
CR	90°	トンガリセンター	6	11	3	41	6	3,100
			8	15	4	45	6	3,300
			10	15	5	45	6	4,800
			12	20	6	50	8	5,100
			16	20	8	50	10	6,700
			20	20	10	50	10	7,400

型番	角度 (θ°)	小径	太径 (D)	外径長 (ℓ1)	刃長 (ℓ)	全長 (L)	シャンク径 (d)	標準価格
CR	90°	トンガリセンター	25	25	12.5	60	12	10,300
			30	30	15	65	12	12,300
			35	30	17.5	67	12	20,600
			40	30	20	70	12	27,700
			45	33	22.5	73	12	41,500
			50	37	25	80	12	52,000
			10	60	45	25	100	16
CR	120°	トンガリセンター	6	10	1.73	41	6	3,100
			8	13	2.31	45	6	3,500
			10	13	2.89	45	6	4,800
			12	15	3.46	50	8	5,200
			16	15	4.62	50	10	7,000
			20	20	5.77	50	10	7,700
			25	20	7.22	60	12	10,700
			30	25	8.66	65	12	13,800
			35	25	10.1	67	12	24,400
			40	25	11.55	70	12	32,800
			45	30	12.99	73	12	45,300
50	30	14.43	80	12	60,400			

# (CR-MT) センターリーマ(テーパーシャンク) Center Reamers, MT Shank

材質=HSS

太径公差=+0.3~+0.5

角度公差=±15'

刃数

φ 40~50 9枚

φ 60 11枚

φ 80 13枚

φ 100 15枚

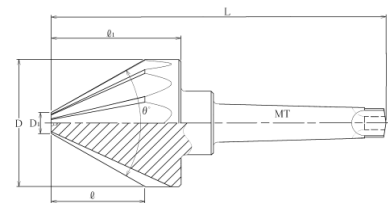
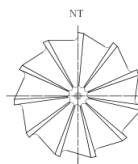

●注文例=型番、角度、太径、シャンク、数量「CR-MT 60°x40xMT2」

型番	角度 (θ°)	小径 (D1)	太径 (D)	外径長 (ℓ1)	刃長 (ℓ)	全長 (L)	シャンク	標準価格
CR-MT	60°	6	40	43	29.4	133	MT2	39,600
		7	50	53	37.2	145	MT2	70,800
		10	60	60	43.3	155	MT2	98,200
		10	80	79	60.6	193	MT3	196,500
		10	100	102	77.9	216	MT3	314,200

型番	角度 (θ°)	小径 (D1)	太径 (D)	外径長 (ℓ1)	刃長 (ℓ)	全長 (L)	シャンク	標準価格
CR-MT	90°	6	40	31	17	121	MT2	35,500
		7	50	38	21.5	130	MT2	63,100
		10	60	42	25	136.5	MT2	94,300
		10	80	54	35	168	MT3	165,100
		10	100	69	45	183	MT3	267,300

# (CC) チャタレス面取フライス

Chatterless Countersinks

SINCE 1935  
F.K.D.®

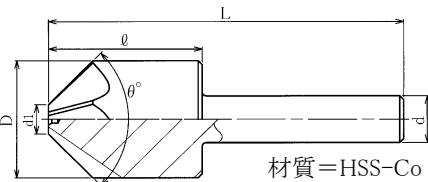
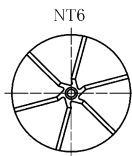

材質=HSS-Co  
刃数=6枚

- 6枚刃により切削力が向上、ビブりのない素晴らしい切れ味、フライス加工での横走も可能、加工中の不快な金属音も大幅に減少。
- 合金鋼、炭素鋼、アルミ、ステンレス等への皿面取り、C面取り加工に最適。
- 再研磨が容易に行えます。
- マシニングセンター、フライス盤、ボール盤等でご使用下さい。

●注文例=型番、角度、太径、数量 「CC 60°x 6」

型番	角度 (θ°)	太径 (D)	小径 (d1)	全長 (L)	外径長 (ℓ)	刃長	シャンク径 (d)	標準価格
CC	60°	6	1.5	60	15	3.9	6	4,300
		8	2	60	15	5.2	6	4,400
		10	2.5	60	15	6.5	8	6,700
		12	3	60	18	7.8	8	7,300
		15	3.7	70	20	9.8	10	9,800
		16	4	70	20	10.4	10	10,400
		18	4.5	70	24	11.7	10	10,700
		20	5	80	28	13	10	11,200
		22	5.5	80	30	14.3	12	15,000
		25	6.2	80	34	16.3	12	15,600
		30	7.5	90	39	19.5	12	18,700
		35	8.7	90	45	22.8	12	30,600
CC	90°	6	1.5	60	15	2.25	6	4,300
		8	2	60	15	3	6	4,400
		10	2.5	60	15	3.75	8	6,700
		12	3	60	18	4.5	8	7,300
		15	3.7	70	20	5.65	10	9,800
		16	4	70	20	6	10	10,400
		18	4.5	70	24	6.75	10	10,700
		20	5	80	28	7.5	10	11,200

型番	角度 (θ°)	太径 (D)	小径 (d1)	全長 (L)	外径長 (ℓ)	刃長	シャンク径 (d)	標準価格
CC	90°	22	5.5	80	30	8.25	12	15,000
		25	6.2	80	34	9.4	12	15,600
		30	7.5	90	39	11.25	12	18,700
		35	8.7	90	45	13.15	12	30,600
		40	10	100	48	15	12	41,200
		45	11.2	110	51	16.9	12	63,200
		50	12.5	120	54	18.75	12	75,100
		CC	120°	6	1.5	60	15	1.3
8	2			60	15	1.73	6	4,400
10	2.5			60	15	2.17	8	6,700
12	3			60	18	2.6	8	7,300
15	3.7			70	20	3.26	10	9,800
16	4			70	20	3.46	10	10,400
18	4.5			70	24	3.9	10	10,700
20	5			80	28	4.33	10	11,200
22	5.5			80	30	4.76	12	15,000
25	6.2			80	34	5.43	12	15,600
30	7.5			90	39	6.5	12	18,700
35	8.7			90	45	7.59	12	30,600
40	10			100	48	8.66	12	41,200
45	11.2			110	51	9.76	12	63,200
50	12.5			120	54	10.83	12	75,100

# (3C) 3Cミル(六角穴付ボルトMC用面取付座繰りカッター)

3C Mills (Centering, Counterbore & Chamfering)

マシニングセンターによって平面部は無論の事、従来ドリルの入って行きにくかった斜面や曲面の部位に対してもセンター・座繰り・面取加工を一度の工程でこなしてしまう優れたもの。

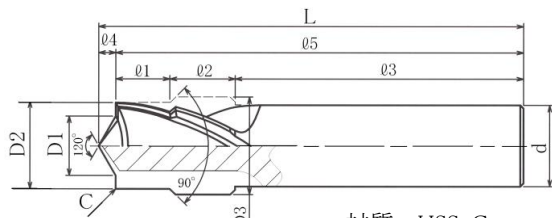
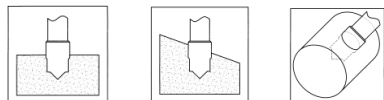

材質=HSS-Co

●注文例=型番、呼称、数量 「3C 3」

型番	呼称	先端径 (D1)	座繰り径 (D2)	面径 (D3)	C面	ℓ1	ℓ2	ℓ4	全長 (L)	シャンク径 (d)	標準価格
3C	3	4	6	8	1	3.5	6	1.15	70	6	9,500
3C	4	4.5	7.5	9.5	1	4.5	8	1.3	75	8	10,400
3C	5	6	9	11	1	5.5	10	1.73	90	10	11,200
3C	6	7.2	10.5	13	1.25	6.5	12	2.08	100	12	13,800
3C	8	10.2	13.5	16	1.25	8.5	12	2.94	110	12	16,000
3C	10	12.2	17	19	1	10.5	15	3.52	115	16	20,300
3C	12	14.2	19	21	1	12.5	15	4.1	120	20	25,800
3C	14	16.2	24.5	28	1.75	14.5	20	4.68	125	25	34,000
3C	16	18.2	26.5	30	1.75	16.5	20	5.25	130	25	41,600

# (CB) 沈めフライス(六角穴付ボルト用) Cap Screw Counterbores



材質=HSS  
刃数=4枚  
リード角=右振れ25°  
外径公差=0~+0.2  
案内径公差=0~-0.05

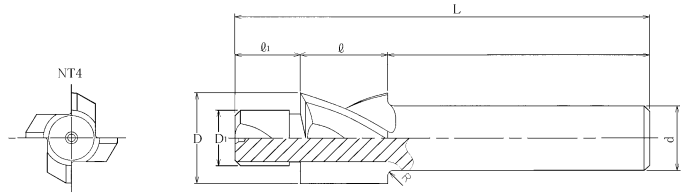

●注文例=型番、呼称、数量「CB 3」

型番	呼称	案内径 (D1)	案内長 (L1)	外径 (D)	刃長 (L)	全長 (L)	シャンク径 (d)	標準価格
CB 3	3	3.2	4	5.9	6	38	6	3,600
CB 4	4	4.2	5	7.4	8	45	6	3,800
CB 5	5	5.2	7	8.9	10	53	6	4,300
CB 6	6	6.2	8	10.4	12	60	8	5,200
CB 8	8	8.2	10	13.4	14	69	10	6,700
CB 10	10	10.3	12	16.8	16	76	12	8,500
CB 12	12	12.3	14	18.8	18	85	12	11,200
CB 14	14	14.3	16	24	20	90	12	13,400
CB 16	16	16.3	18	26	22	100	12	17,800

○インチサイズ

型番	呼称	案内径 (D1)	案内長 (L1)	外径 (D)	刃長 (L)	全長 (L)	シャンク径 (d)	標準価格
CB 1/8"	1/8"	3.4	4	6.2	6	38	6	3,800
CB 3/16"	3/16"	4.96	7	8.7	10	53	6	4,200
CB 1/4"	1/4"	6.55	8	11	12	60	8	5,900
CB 5/16"	5/16"	8.25	10	14	14	69	10	6,700
CB 3/8"	3/8"	9.8	12	15	16	76	12	8,500
CB 1/2"	1/2"	13.2	14	20	18	85	12	12,600
CB 5/8"	5/8"	16.5	18	26	22	100	12	18,700

# (CBT) 沈めフライス(六角穴付ボルト用)テーパシャンク Cap Screw Counterbores, MT Shank

材質=HSS  
刃数=4枚  
リード角=右振れ15°  
外径公差=0~+0.2  
案内径公差=0~-0.05

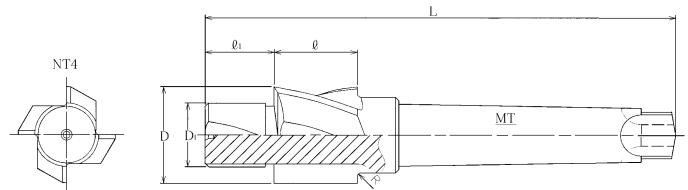

●注文例=型番、呼称、シャンク、数量「CBT 10xMT1」

型番	呼称	案内径 (D1)	案内長 (L1)	外径 (D)	刃長 (L)	全長 (L)	シャンク	標準価格
CBT 10	10	10.3	12	16.8	16	101.5	MT1	11,400
CBT 12	12	12.4	14	18.8	18	106.5	MT1	13,000
CBT 14	14	14.4	16	24	20	110.5	MT1	15,600
CBT 16	16	16.5	18	26	22	130.5	MT2	19,300
CBT 18	18	18.5	20	28	24	134.5	MT2	23,600
CBT 20	20	21	22	30	26	138.5	MT2	29,800
CBT 22	22	23	24	32	28	142.5	MT2	39,700
CBT 24	24	25	26	36	32	170	MT3	51,200
CBT 30	30	31.5	32	45	38	182	MT3	73,900
CBT 36	36	37.5	39	53	44	196	MT3	94,600
CBT 42	42	44	45	59	52	210	MT3	114,700
CBT 45	45	47	48	64	55	243	MT4	176,300
CBT 48	48	50	51	67	58	249	MT4	205,100

MTシャンク

○インチサイズ

型番	呼称	案内径 (D1)	案内長 (L1)	外径 (D)	刃長 (L)	全長 (L)	シャンク	標準価格
CBT 3/8"	3/8"	9.8	12	15	16	101.5	MT1	11,600
CBT 1/2"	1/2"	13.2	14	20	18	106.5	MT1	14,000
CBT 5/8"	5/8"	16.5	18	26	22	130.5	MT2	19,300
CBT 3/4"	3/4"	20	22	29	26	138.5	MT2	25,400
CBT 7/8"	7/8"	23	24	32	28	142.5	MT2	39,700
CBT 1"	1"	26.5	26	37	32	170	MT3	53,000
CBT 1.1/4"	1.1/4"	33	32	49	42	187	MT3	76,000
CBT 1.1/2"	1.1/2"	40	39	57	50	202	MT3	106,600
CBT 1.3/4"	1.3/4"	46	48	64	56	244	MT4	180,500
CBT 2"	2"	53	51	70	62	253	MT4	258,200



# (EP-CB) 押し出しピン用沈めフライス

SINCE 1935  
F.K.D.®

Ejector Pin Counterbores

材質=HSS-Co  
刃数=4枚  
リード角(右振り)  
2~3.5=15°  
4~16=25°  
外径公差=0~+0.2

案内径公差  
2~2.5 -0.014~-0.024  
3~5 -0.020~-0.032  
6~9 -0.025~-0.040  
10~16 -0.032~-0.050

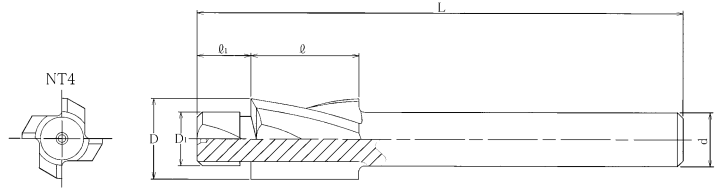

●注文例=型番、呼称、数量「EP-CB 2」

型番	呼称	案内径 (D1)	案内長 (l1)	外径 (D)	刃長 (l)	全長 (L)	シャンク径 (d)	標準価格
EP-CB 2	2	2	3	6	8	50	6	5,300
EP-CB 2.5	2.5	2.5	3	6	8	50	6	5,300
EP-CB 3	3	3	3	6	8	50	6	5,300
EP-CB 3.5	3.5	3.5	4	8	10	50	6	5,300
EP-CB 4	4	4	4	8	10	50	6	5,300
EP-CB 4.5	4.5	4.5	5	9	12	65	6	6,100
EP-CB 5	5	5	5	9	12	65	6	6,100
EP-CB 6	6	6	6	10	15	70	8	7,100

型番	呼称	案内径 (D1)	案内長 (l1)	外径 (D)	刃長 (l)	全長 (L)	シャンク径 (d)	標準価格
EP-CB 7	7	7	6	11	15	70	8	7,400
EP-CB 8	8	8	8	13	18	80	10	9,200
EP-CB 9	9	9	8	14	18	80	10	9,200
EP-CB 10	10	10	10	15	20	90	10	10,000
EP-CB 12	12	12	10	17	20	90	10	12,600
EP-CB 14	14	14	12	19	25	100	12	14,900
EP-CB 16	16	16	13	21	25	100	12	17,800

# (MS-CB) 皿小ネジ用沈めフライス

Machine Screw Counterbores

●注文例=型番、呼称、数量「MS-CB 3」

型番	呼称	案内径 (D1)	案内長 (l1)	外径 (D)	刃長 (l)	全長 (L)	シャンク径 (d)	標準価格
MS-CB 3	3	3.2	4	7.5	6	38	6	4,200
MS-CB 4	4	4.2	5	9.5	8	45	6	4,300
MS-CB 5	5	5.2	7	12	10	53	8	5,200
MS-CB 6	6	6.2	8	14	12	60	10	6,700
MS-CB 8	8	8.2	10	18.5	14	69	10	9,100

材質=HSS  
刃数=4枚

リード角=右振り12°  
外径公差=0~+0.2

案内径公差=0~-0.05

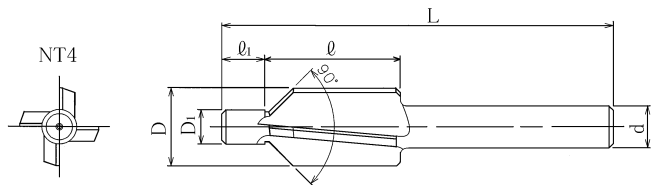

# (LS-CB) ロングシャンク沈めフライス (JIS規格)

Long Shank Cap Screw Counterbores (JIS Cap Screw)

外径公差

3~5 +0.042~+0.078  
6~8 +0.050~+0.093  
10 +0.060~+0.103  
12~14 +0.073~+0.125  
16~18 +0.088~+0.140  
20~24 +0.112~+0.174  
30 +0.136~+0.198  
1/4~5/16 +0.050~+0.093  
3/8 +0.060~+0.103  
1/2 +0.073~+0.125

案内径公差

3~5 -0.020~-0.038  
6~8 -0.025~-0.047  
10~16 -0.032~-0.059  
18~30 -0.043~-0.073  
1/4~3/8 -0.025~-0.047  
1/2 -0.032~-0.059

材質=HSS-Co  
刃数=4枚

リード角=右振り25°

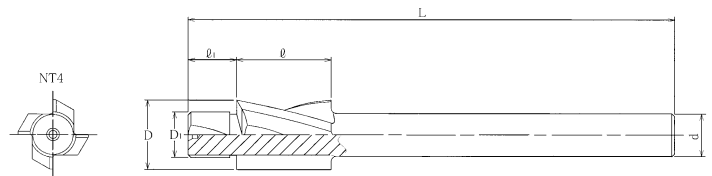

●注文例=型番、呼称、数量「LS-CB 3」

型番	呼称	案内径 (D1)	案内長 (l1)	外径 (D)	刃長 (l)	全長 (L)	シャンク径 (d)	標準価格
LS-CB 3	3	3.2	4	6.5	14	110	6	8,000
LS-CB 4	4	4.3	5	8	14	120	6	8,000
LS-CB 5	5	5.3	7	9.5	18	120	8	10,200
LS-CB 6	6	6.4	8	11	18	120	8	10,400
LS-CB 8	8	8.4	10	14	22	120	10	12,200
LS-CB 10	10	10.5	12	17.5	25	160	12	14,600
LS-CB 12	12	13	14	20	25	160	12	16,300
LS-CB 14	14	15	16	23	30	180	12	20,800
LS-CB 16	16	17	18	26	35	180	16	25,700

型番	呼称	案内径 (D1)	案内長 (l1)	外径 (D)	刃長 (l)	全長 (L)	シャンク径 (d)	標準価格
LS-CB 18	18	19	20	29	35	200	16	28,800
LS-CB 20	20	21	20	32	40	200	16	32,900
LS-CB 22	22	23	24	35	40	200	16	39,000
LS-CB 24	24	25	25	39	40	220	20	49,400
LS-CB 30	30	31.5	30	48	40	220	20	73,900
LS-CB 1/4"	1/4"	6.7	8	12	18	120	8	10,900
LS-CB 5/16"	5/16"	8.5	10	14	22	120	10	12,200
LS-CB 3/8"	3/8"	10	12	16	25	160	12	14,600
LS-CB 1/2"	1/2"	14	14	21	25	160	12	18,700

特定代理店在庫

# (DCB) ドリル付沈めフライス(六角穴付ボルト用)

SINCE 1935

F.K.D.®

材質=HSS  
刃数=2枚

リード角=右振れ25°  
外径公差=0~+0.2  
ドリル径公差=0~-0.05

●注文例=型番、呼称、数量「DCB 3」

型番	呼称	ドリル径 (D1)	ドリル長 (ℓ1)	外径 (D)	刃長 (ℓ)	全長 (L)	シャンク径 (d)	標準価格
DCB 3	3	3.5	15	5.9	7	50	6	3,600
DCB 4	4	4.5	15	7.4	9	55	6	4,300
DCB 5	5	5.5	20	8.9	12	63	8	4,600
DCB 6	6	6.5	25	10.4	13	70	8	5,300
DCB 8	8	8.5	30	13.4	16	79	10	6,900
DCB 10	10	10.6	35	16.8	20	87	12	9,100
DCB 12	12	12.7	35	18.8	23	92	12	11,600
DCB 14	14	15	35	24	29	98	12	16,300

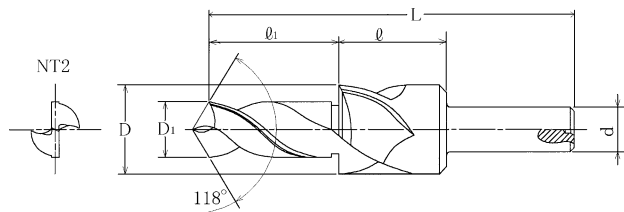

特定代理店在庫

# (DCS) ドリル付皿小ネジ用沈めフライス

Machine Screw Counterbores with Drill

材質=HSS  
刃数=2枚

リード角=右振れ25°  
外径公差=0~+0.2  
ドリル径公差=0~-0.05

●注文例=型番、呼称、数量「DCS 3」

型番	呼称	ドリル径 (D1)	ドリル長 (ℓ1)	外径 (D)	刃長 (ℓ)	全長 (L)	シャンク径 (d)	標準価格
DCS 3	3	3.5	10	7.5	10	44	6	3,800
DCS 4	4	4.5	15	9.5	14	55	6	4,700
DCS 5	5	5.5	15	12	16	61	8	5,900
DCS 6	6	6.5	20	14	16	71	10	7,000
DCS 8	8	8.5	22	18.5	18	76	10	9,700

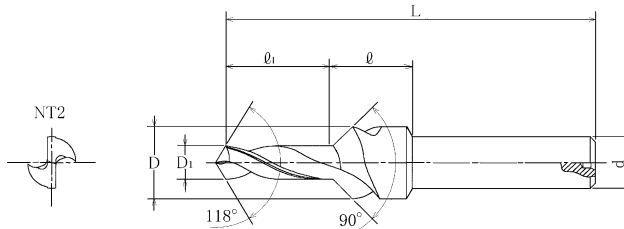

特定代理店在庫

# (DSS) ドリル付皿小ネジ下穴用沈めフライス

Machine Screw Counterbores with Drill, (Pre-Tapping Sizes)

材質=HSS  
刃数=2枚

リード角=右振れ25°  
外径公差=0~+0.2  
ドリル径公差=0~-0.05

●注文例=型番、呼称、数量「DSS 4」

型番	呼称	ドリル径 (D1)	ドリル長 (ℓ1)	外径 (D)	刃長 (ℓ)	全長 (L)	シャンク径 (d)	標準価格
DSS 4	4	3.3	15	9.5	14	55	6	4,800
DSS 5	5	4.2	15	12	16	61	8	5,900
DSS 6	6	5	20	14	16	71	10	7,000
DSS 8	8	6.8	22	18.5	18	76	10	9,700

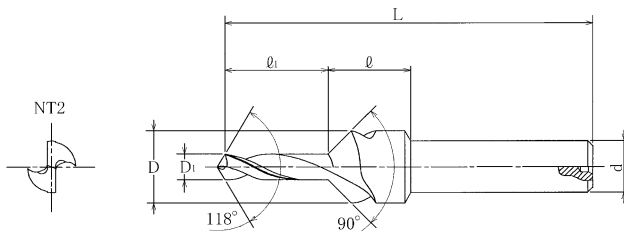

(SC)  
普通刃サイドカッター  
Side Milling Cutters, Straight Tooth

SINCE 1935  
F.K.D.®

材質=HSS

刃数

サイド刃高さ(H)

刃径公差=0~+0.5

φ 50 3~15 18枚 φ 125 3~12 30枚  
φ 60 3~16 20枚 13~30 28枚  
φ 65 3~15 20枚 φ 150 3~12 34枚  
φ 75 3~25 22枚 13~30 32枚  
φ 80 3~15 24枚 φ 175 5~12 36枚  
φ 90 3~16 24枚 13~30 34枚  
φ 100 3~12 28枚 φ 200 5~12 38枚  
13~30 26枚 13~30 36枚

φ 50 6 φ 100 14  
φ 60 8 φ 125 17.5  
φ 65 8.5 φ 150 18  
φ 75 10.5 φ 175 22.5  
φ 80 11 φ 200 25  
φ 90 12

刃幅公差

3 ~ 7 0~+0.05  
7.5~11 0~+0.06  
11.5~30 0~+0.07

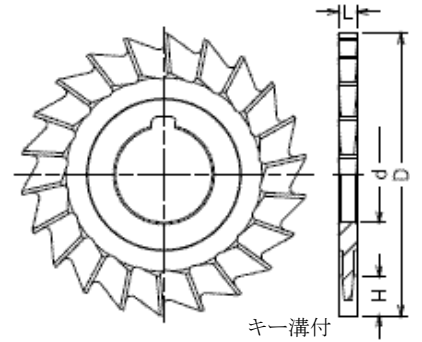

キー溝付

●注文例=型番、刃径、刃幅、穴径、数量「SC 75x3x25.4」 ※◎印受注生産にて受け承ります。

型番	刃径(D)	刃幅(L)	穴径(d)	標準価格
◎SC	50	3	15.875	11,400
◎SC	50	4	15.875	11,400
◎SC	50	5	15.875	10,800
◎SC	50	6	15.875	11,300
◎SC	50	7	15.875	11,300
◎SC	50	8	15.875	12,500
◎SC	50	9	15.875	12,800
◎SC	50	10	15.875	13,700
◎SC	50	12	15.875	14,800
◎SC	50	15	15.875	19,000
◎SC	60	3	25.4	13,700
◎SC	60	4	25.4	13,700
◎SC	60	5	25.4	12,800
◎SC	60	6	25.4	13,400
◎SC	60	7	25.4	14,000
◎SC	60	8	25.4	15,200
◎SC	60	9	25.4	16,000
◎SC	60	10	25.4	16,800
◎SC	60	11	25.4	17,800
◎SC	60	12	25.4	18,200
◎SC	60	14	25.4	19,400
◎SC	60	15	25.4	20,400
◎SC	60	16	25.4	21,800
◎SC	65	3	25.4	14,900
◎SC	65	4	25.4	14,900
◎SC	65	5	25.4	14,900
◎SC	65	6	25.4	14,900
◎SC	65	7	25.4	16,000
◎SC	65	8	25.4	16,800
◎SC	65	9	25.4	18,000
◎SC	65	10	25.4	19,000
◎SC	65	11	25.4	19,300
◎SC	65	12	25.4	20,300
◎SC	65	14	25.4	22,200
◎SC	65	15	25.4	23,300
SC	75	3	25.4	17,500
SC	75	3.5	25.4	16,000
SC	75	4	25.4	16,000
SC	75	4.5	25.4	15,500
SC	75	5	25.4	15,500
SC	75	5.5	25.4	15,500
SC	75	6	25.4	15,500
SC	75	6.5	25.4	16,700

型番	刃径(D)	刃幅(L)	穴径(d)	標準価格
SC	75	7	25.4	16,700
SC	75	7.5	25.4	16,700
SC	75	8	25.4	16,700
SC	75	8.5	25.4	18,200
SC	75	9	25.4	18,200
SC	75	10	25.4	18,200
SC	75	11	25.4	20,300
SC	75	12	25.4	20,300
SC	75	13	25.4	22,100
SC	75	14	25.4	22,100
SC	75	15	25.4	23,600
SC	75	16	25.4	23,600
SC	75	17	25.4	28,400
SC	75	18	25.4	28,400
SC	75	19	25.4	33,000
SC	75	20	25.4	33,000
SC	75	22	25.4	37,700
SC	75	23	25.4	39,200
SC	75	24	25.4	39,200
SC	75	25	25.4	40,300
◎SC	80	3	25.4	24,200
◎SC	80	4	25.4	22,300
◎SC	80	5	25.4	23,200
◎SC	80	6	25.4	23,600
◎SC	80	7	25.4	24,700
◎SC	80	8	25.4	25,800
◎SC	80	9	25.4	27,500
◎SC	80	10	25.4	28,600
◎SC	80	11	25.4	29,400
◎SC	80	12	25.4	32,000
◎SC	80	14	25.4	35,800
◎SC	80	15	25.4	37,400
◎SC	90	3	25.4	26,300
◎SC	90	4	25.4	23,600
◎SC	90	5	25.4	24,200
◎SC	90	6	25.4	25,100
◎SC	90	7	25.4	26,300
◎SC	90	8	25.4	27,500
◎SC	90	9	25.4	28,600
◎SC	90	10	25.4	29,400
◎SC	90	11	25.4	31,400
◎SC	90	12	25.4	33,500
◎SC	90	14	25.4	37,000

(SC)  
普通刃サイドカッター  
Side Milling Cutters, Straight Tooth

SINCE 1935  
F.K.D.®

材質=HSS

刃数

刃径公差=0~+0.5

刃幅公差

3 ~ 7 0~+0.05

7.5~11 0~+0.06

11.5~30 0~+0.07

φ 50	3~15	18枚	φ 125	3~12	30枚
φ 60	3~16	20枚		13~30	28枚
φ 65	3~15	20枚	φ 150	3~12	34枚
φ 75	3~25	22枚		13~30	32枚
φ 80	3~15	24枚	φ 175	5~12	36枚
φ 90	3~16	24枚		13~30	34枚
φ 100	3~12	28枚	φ 200	5~12	38枚
		13~30	26枚	13~30	36枚

サイド刃高さ(H)

φ 50	6	φ 100	14
φ 60	8	φ 125	17.5
φ 65	8.5	φ 150	18
φ 75	10.5	φ 175	22.5
φ 80	11	φ 200	25
φ 90	12		

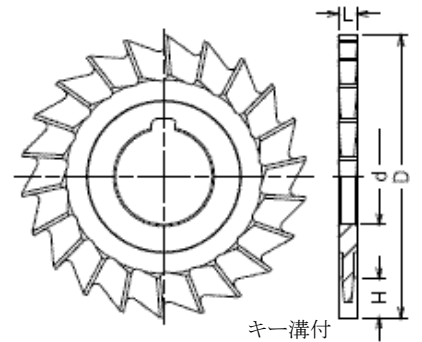

●注文例=型番、刃径、刃幅、穴径、数量「SC 100x3x25.4」 ※◎印受注生産にて受け承ります。

型番	刃径(D)	刃幅(L)	穴径(d)	標準価格
◎SC	90	15	25.4	39,500
◎SC	90	16	25.4	41,000
SC	100	3	25.4	26,400
SC	100	3.5	25.4	23,600
SC	100	4	25.4	23,600
SC	100	4.5	25.4	23,600
SC	100	5	25.4	23,600
SC	100	5.5	25.4	23,600
SC	100	6	25.4	23,600
SC	100	6.5	25.4	25,700
SC	100	7	25.4	25,700
SC	100	7.5	25.4	25,700
SC	100	8	25.4	25,700
SC	100	8.5	25.4	28,400
SC	100	9	25.4	28,400
SC	100	9.5	25.4	28,400
SC	100	10	25.4	28,400
SC	100	10.5	25.4	33,000
SC	100	11	25.4	33,000
SC	100	12	25.4	33,000
SC	100	13	25.4	36,100
SC	100	14	25.4	36,100
SC	100	15	25.4	38,900
SC	100	16	25.4	39,800
SC	100	17	25.4	44,300
SC	100	18	25.4	44,300
SC	100	19	25.4	47,500
SC	100	20	25.4	47,500
SC	100	22	25.4	55,000
SC	100	23	25.4	60,400
SC	100	24	25.4	60,400
SC	100	25	25.4	64,300
SC	100	26	25.4	67,700
SC	100	28	25.4	74,800
SC	100	29	25.4	82,400
SC	100	30	25.4	82,400
◎SC	100	3	31.75	26,400
◎SC	100	4	31.75	23,600
◎SC	100	5	31.75	23,600
◎SC	100	6	31.75	23,600
◎SC	100	7	31.75	25,700
◎SC	100	8	31.75	25,700
◎SC	100	9	31.75	28,400

型番	刃径(D)	刃幅(L)	穴径(d)	標準価格
◎SC	100	10	31.75	28,400
◎SC	100	11	31.75	33,000
◎SC	100	12	31.75	33,000
◎SC	100	13	31.75	36,100
◎SC	100	14	31.75	36,100
◎SC	100	15	31.75	38,900
◎SC	100	16	31.75	39,800
◎SC	100	18	31.75	44,300
◎SC	100	20	31.75	47,500
SC	125	3	25.4	51,100
SC	125	3.5	25.4	44,000
SC	125	4	25.4	44,000
SC	125	4.5	25.4	42,200
SC	125	5	25.4	42,200
SC	125	5.5	25.4	42,200
SC	125	6	25.4	42,200
SC	125	7	25.4	42,200
SC	125	7.5	25.4	44,000
SC	125	8	25.4	44,000
SC	125	8.5	25.4	45,700
SC	125	9	25.4	45,700
SC	125	9.5	25.4	45,700
SC	125	10	25.4	45,700
SC	125	10.5	25.4	50,600
SC	125	11	25.4	50,600
SC	125	12	25.4	50,600
SC	125	12.5	25.4	56,800
SC	125	13	25.4	56,800
SC	125	14	25.4	56,800
SC	125	15	25.4	60,400
SC	125	16	25.4	62,200
SC	125	17	25.4	69,600
SC	125	18	25.4	69,600
SC	125	19	25.4	80,400
SC	125	20	25.4	80,400
SC	125	22	25.4	83,900
SC	125	24	25.4	89,500
SC	125	25	25.4	94,900
SC	125	26	25.4	94,900
SC	125	28	25.4	102,200
SC	125	29	25.4	109,600
SC	125	30	25.4	109,600
◎SC	125	3	31.75	51,100

(SC)  
普通刃サイドカッター  
Side Milling Cutters, Straight Tooth



材質=HSS

刃数

刃径公差=0~+0.5

刃幅公差

3 ~ 7 0~+0.05

7.5~11 0~+0.06

11.5~30 0~+0.07

φ 50	3~15	18枚	φ 125	3~12	30枚	
φ 60	3~16	20枚		13~30	28枚	
φ 65	3~15	20枚	φ 150	3~12	34枚	
φ 75	3~25	22枚		13~30	32枚	
φ 80	3~15	24枚	φ 175	5~12	36枚	
φ 90	3~16	24枚		13~30	34枚	
φ 100	3~12	28枚	φ 200	5~12	38枚	
				13~30	26枚	
					13~30	36枚

サイド刃高さ(H)

φ 50	6	φ 100	14
φ 60	8	φ 125	17.5
φ 65	8.5	φ 150	18
φ 75	10.5	φ 175	22.5
φ 80	11	φ 200	25
φ 90	12		

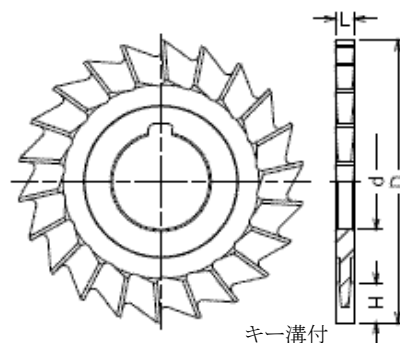

キー溝付

●注文例=型番、刃径、刃幅、穴径、数量「SC 150x4x25.4」 ※◎印受注生産にて受け承ります。

型番	刃径(D)	刃幅(L)	穴径(d)	標準価格
◎SC	125	4	31.75	44,000
◎SC	125	5	31.75	42,200
◎SC	125	6	31.75	42,200
◎SC	125	7	31.75	42,200
◎SC	125	8	31.75	44,000
◎SC	125	9	31.75	45,700
◎SC	125	10	31.75	45,700
◎SC	125	11	31.75	50,600
◎SC	125	12	31.75	50,600
◎SC	125	13	31.75	56,800
◎SC	125	14	31.75	56,800
◎SC	125	15	31.75	60,400
◎SC	125	16	31.75	62,200
◎SC	125	18	31.75	69,600
◎SC	125	20	31.75	80,400
SC	150	4	25.4	62,200
SC	150	5	25.4	62,200
SC	150	6	25.4	62,200
SC	150	7	25.4	62,200
SC	150	8	25.4	62,200
SC	150	9	25.4	65,900
SC	150	10	25.4	65,900
SC	150	10.5	25.4	73,000
SC	150	11	25.4	73,000
SC	150	12	25.4	73,000
SC	150	12.5	25.4	83,900
SC	150	13	25.4	83,900
SC	150	14	25.4	83,900
SC	150	15	25.4	88,000
SC	150	16	25.4	91,200
SC	150	17	25.4	98,600
SC	150	18	25.4	98,600
SC	150	19	25.4	109,600
SC	150	20	25.4	109,600
SC	150	22	25.4	120,500
SC	150	24	25.4	131,400
SC	150	25	25.4	135,200
SC	150	26	25.4	138,800
SC	150	28	25.4	146,000
SC	150	30	25.4	153,500
◎SC	150	4	31.75	62,200
◎SC	150	5	31.75	62,200
◎SC	150	6	31.75	62,200

型番	刃径(D)	刃幅(L)	穴径(d)	標準価格
◎SC	150	7	31.75	62,200
◎SC	150	8	31.75	62,200
◎SC	150	9	31.75	65,900
◎SC	150	10	31.75	65,900
◎SC	150	11	31.75	73,000
◎SC	150	12	31.75	73,000
◎SC	150	13	31.75	83,900
◎SC	150	14	31.75	83,900
◎SC	150	15	31.75	88,000
◎SC	150	16	31.75	91,200
◎SC	150	18	31.75	98,600
◎SC	150	20	31.75	109,600
SC	175	6	25.4	94,900
SC	175	7	25.4	94,900
SC	175	8	25.4	98,600
SC	175	9	25.4	102,200
SC	175	10	25.4	102,200
SC	175	11	25.4	117,000
SC	175	12	25.4	117,000
SC	175	14	25.4	127,900
SC	175	15	25.4	127,900
SC	175	16	25.4	135,200
SC	175	18	25.4	153,500
SC	175	20	25.4	168,000
SC	175	22	25.4	171,800
SC	175	24	25.4	193,400
SC	175	25	25.4	200,900
SC	175	26	25.4	208,100
SC	175	28	25.4	211,800
SC	175	30	25.4	219,100
◎SC	175	6	31.75	94,900
◎SC	175	8	31.75	98,600
◎SC	175	10	31.75	102,200
◎SC	175	12	31.75	117,000
◎SC	175	15	31.75	127,900
◎SC	175	16	31.75	135,200
◎SC	175	18	31.75	153,500
◎SC	175	20	31.75	168,000
SC	200	6	25.4	135,200
SC	200	7	25.4	135,200
SC	200	8	25.4	135,200
SC	200	9	25.4	146,000
SC	200	10	25.4	146,000

(SC)  
普通刃サイドカッター  
Side Milling Cutters, Straight Tooth

SINCE 1935  
F.K.D.®

材質=HSS

刃数

刃径公差=0~+0.5

刃幅公差

3 ~ 7 0~+0.05

7.5~11 0~+0.06

11.5~30 0~+0.07

φ 50	3~15	18枚	φ 125	3~12	30枚	
φ 60	3~16	20枚		13~30	28枚	
φ 65	3~15	20枚	φ 150	3~12	34枚	
φ 75	3~25	22枚		13~30	32枚	
φ 80	3~15	24枚	φ 175	5~12	36枚	
φ 90	3~16	24枚		13~30	34枚	
φ 100	3~12	28枚	φ 200	5~12	38枚	
		13~30	26枚		13~30	36枚

サイド刃高さ(H)

φ 50	6	φ 100	14
φ 60	8	φ 125	17.5
φ 65	8.5	φ 150	18
φ 75	10.5	φ 175	22.5
φ 80	11	φ 200	25
φ 90	12		

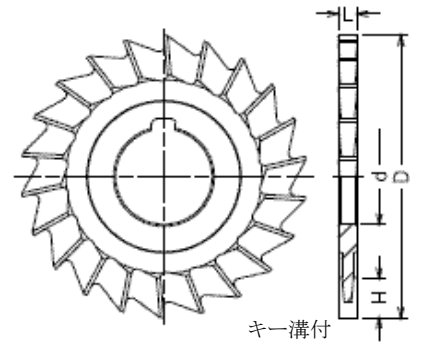

キー溝付

●注文例=型番、刃径、刃幅、穴径、数量「SC 200x11x25.4」 ※◎印受注生産にて受け承ります。

型番	刃径(D)	刃幅(L)	穴径(d)	標準価格
SC	200	11	25.4	153,500
SC	200	12	25.4	153,500
SC	200	14	25.4	164,400
SC	200	15	25.4	182,800
SC	200	16	25.4	182,800
SC	200	18	25.4	200,900
SC	200	20	25.4	222,600
SC	200	22	25.4	237,200
SC	200	24	25.4	244,600
SC	200	25	25.4	248,400
SC	200	26	25.4	251,900

型番	刃径(D)	刃幅(L)	穴径(d)	標準価格
SC	200	28	25.4	259,300
SC	200	30	25.4	266,600
◎SC	200	6	31.75	135,200
◎SC	200	8	31.75	135,200
◎SC	200	10	31.75	146,000
◎SC	200	12	31.75	153,500
◎SC	200	15	31.75	182,800
◎SC	200	16	31.75	182,800
◎SC	200	18	31.75	200,900
◎SC	200	20	31.75	222,600

○(インチ幅サイズ)

●注文例=型番、刃径、刃幅、穴径、数量「SC 75x1/8"x25.4」

型番	刃径(D)	刃幅(L)	穴径(d)	標準価格
SC	75	1/8"	25.4	17,500
SC	75	1/4"	25.4	16,700
SC	75	5/16"	25.4	16,700
SC	75	3/8"	25.4	18,200
SC	75	1/2"	25.4	22,100

型番	刃径(D)	刃幅(L)	穴径(d)	標準価格
SC	100	1/8"	25.4	26,400
SC	100	3/16"	25.4	23,600
SC	100	1/4"	25.4	25,700
SC	100	5/16"	25.4	25,700
SC	100	3/8"	25.4	28,400
SC	100	1/2"	25.4	36,100
SC	125	1/4"	25.4	42,200
SC	125	1/2"	25.4	56,800

(SSC)  
千鳥刃サイドカッター  
Side Milling Cutters, Staggered Tooth

SINCE 1935  
F.K.D.®

材質=HSS-Co

サイド刃高さ(H)

刃数

左右振れ角

刃径公差=0~+0.5

φ 75 10.5

φ 75 16枚

L ≤ 16 15°

φ 100 14

φ 100 18枚

16 < L < 25 12°

φ 125 16

φ 125 22枚

25 ≤ L 10°

刃幅公差

φ 150 18

φ 150 24枚

3 ~ 7 0~+0.05

φ 175 20

φ 175 26枚

7.5~11 0~+0.06

φ 200 22

φ 200 28枚

11.5~30 0~+0.07

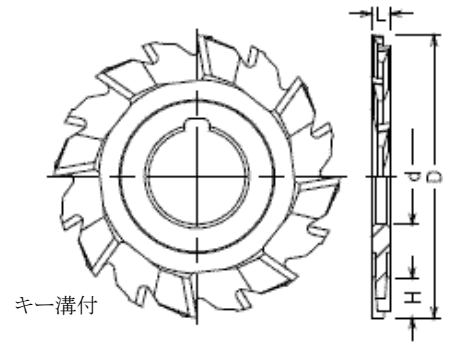

●注文例=型番、刃径、刃幅、穴径、数量「SSC 75x3x25.4」

型番	刃径 (D)	刃幅 (L)	穴径 (d)	標準価格
SSC	75	3	25.4	23,600
SSC	75	3.5	25.4	22,100
SSC	75	4	25.4	22,100
SSC	75	4.5	25.4	20,300
SSC	75	5	25.4	20,300
SSC	75	5.5	25.4	20,300
SSC	75	6	25.4	20,300
SSC	75	6.5	25.4	22,100
SSC	75	7	25.4	22,100
SSC	75	7.5	25.4	22,100
SSC	75	8	25.4	22,100
SSC	75	8.5	25.4	23,600
SSC	75	9	25.4	23,600
SSC	75	9.5	25.4	23,600
SSC	75	10	25.4	23,600
SSC	75	10.5	25.4	25,700
SSC	75	11	25.4	25,700
SSC	75	11.5	25.4	25,700
SSC	75	12	25.4	25,700
SSC	75	12.5	25.4	29,400
SSC	75	13	25.4	29,400
SSC	75	14	25.4	29,400
SSC	75	15	25.4	31,600
SSC	75	16	25.4	31,600
SSC	75	17	25.4	36,700
SSC	75	18	25.4	36,700
SSC	75	19	25.4	44,000
SSC	75	20	25.4	44,000
SSC	75	21	25.4	46,600
SSC	75	22	25.4	46,600
SSC	75	23	25.4	49,400
SSC	75	24	25.4	49,400
SSC	75	25	25.4	52,200
SSC	75	26	25.4	56,300
SSC	75	27	25.4	60,400
SSC	75	28	25.4	60,400
SSC	75	30	25.4	68,000
SSC	100	3	25.4	34,800
SSC	100	3.5	25.4	32,000
SSC	100	4	25.4	32,000
SSC	100	4.5	25.4	31,600
SSC	100	5	25.4	31,600
SSC	100	5.5	25.4	31,600

型番	刃径 (D)	刃幅 (L)	穴径 (d)	標準価格
SSC	100	6	25.4	31,600
SSC	100	6.5	25.4	34,200
SSC	100	7	25.4	34,200
SSC	100	7.5	25.4	34,200
SSC	100	8	25.4	34,200
SSC	100	8.5	25.4	36,700
SSC	100	9	25.4	36,700
SSC	100	9.5	25.4	36,700
SSC	100	10	25.4	36,700
SSC	100	10.5	25.4	44,000
SSC	100	11	25.4	44,000
SSC	100	11.5	25.4	44,000
SSC	100	12	25.4	44,000
SSC	100	12.5	25.4	48,600
SSC	100	13	25.4	48,600
SSC	100	14	25.4	48,600
SSC	100	15	25.4	53,300
SSC	100	16	25.4	55,000
SSC	100	17	25.4	58,800
SSC	100	18	25.4	58,800
SSC	100	19	25.4	69,600
SSC	100	20	25.4	69,600
SSC	100	21	25.4	73,000
SSC	100	22	25.4	73,000
SSC	100	23	25.4	80,400
SSC	100	24	25.4	80,400
SSC	100	25	25.4	83,900
SSC	100	26	25.4	88,000
SSC	100	27	25.4	94,900
SSC	100	28	25.4	94,900
SSC	100	30	25.4	102,200
SSC	100	3	31.75	34,800
SSC	100	3.5	31.75	32,000
SSC	100	4	31.75	32,000
SSC	100	5	31.75	31,600
SSC	100	6	31.75	31,600
SSC	100	7	31.75	34,200
SSC	100	8	31.75	34,200
SSC	100	9	31.75	36,700
SSC	100	10	31.75	36,700
SSC	100	11	31.75	44,000
SSC	100	12	31.75	44,000
SSC	100	13	31.75	48,600

# (SSC) 千鳥刃サイドカッター

Side Milling Cutters, Staggered Tooth

SINCE 1935  
F.K.D.®

材質=HSS-Co

サイド刃高さ(H)

刃数

左右振れ角

刃径公差=0~+0.5

φ 75 10.5

φ 75 16枚

L ≤ 16 15°

φ 100 14

φ 100 18枚

16 < L < 25 12°

φ 125 16

φ 125 22枚

25 ≤ L 10°

刃幅公差

φ 150 18

φ 150 24枚

3 ~ 7 0~+0.05

φ 175 20

φ 175 26枚

7.5~11 0~+0.06

φ 200 22

φ 200 28枚

11.5~30 0~+0.07

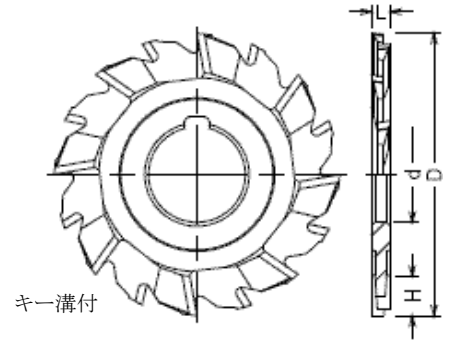

●注文例=型番、刃径、刃幅、穴径、数量「SSC 100x14x31.75」

型番	刃径 (D)	刃幅 (L)	穴径 (d)	標準価格
SSC	100	14	31.75	48,600
SSC	100	15	31.75	53,300
SSC	100	16	31.75	55,000
SSC	100	17	31.75	58,800
SSC	100	18	31.75	58,800
SSC	100	19	31.75	69,600
SSC	100	20	31.75	69,600
SSC	100	22	31.75	73,000
SSC	100	24	31.75	80,400
SSC	100	25	31.75	83,900
SSC	100	26	31.75	88,000
SSC	100	28	31.75	94,900
SSC	100	30	31.75	102,200
SSC	125	3	25.4	58,800
SSC	125	3.5	25.4	58,800
SSC	125	4	25.4	58,800
SSC	125	4.5	25.4	56,300
SSC	125	5	25.4	56,300
SSC	125	5.5	25.4	56,300
SSC	125	6	25.4	56,300
SSC	125	6.5	25.4	56,300
SSC	125	7	25.4	56,300
SSC	125	7.5	25.4	56,300
SSC	125	8	25.4	56,300
SSC	125	8.5	25.4	60,400
SSC	125	9	25.4	60,400
SSC	125	9.5	25.4	60,400
SSC	125	10	25.4	60,400
SSC	125	10.5	25.4	66,400
SSC	125	11	25.4	66,400
SSC	125	11.5	25.4	66,400
SSC	125	12	25.4	66,400
SSC	125	12.5	25.4	69,600
SSC	125	13	25.4	69,600
SSC	125	14	25.4	72,600
SSC	125	15	25.4	78,500
SSC	125	16	25.4	78,500
SSC	125	17	25.4	86,600
SSC	125	18	25.4	86,600
SSC	125	19	25.4	100,600
SSC	125	20	25.4	100,600
SSC	125	22	25.4	106,100
SSC	125	24	25.4	112,400
SSC	125	25	25.4	118,600
SSC	125	26	25.4	120,500
SSC	125	28	25.4	140,600
SSC	125	30	25.4	148,800
SSC	150	3	25.4	88,000
SSC	150	3.5	25.4	88,000
SSC	150	4	25.4	88,000
SSC	150	4.5	25.4	80,400
SSC	150	5	25.4	80,400
SSC	150	5.5	25.4	80,400
SSC	150	6	25.4	80,400
SSC	150	6.5	25.4	80,400
SSC	150	7	25.4	80,400
SSC	150	7.5	25.4	80,400
SSC	150	8	25.4	80,400

型番	刃径 (D)	刃幅 (L)	穴径 (d)	標準価格
SSC	125	23	25.4	112,400
SSC	125	24	25.4	112,400
SSC	125	25	25.4	118,600
SSC	125	26	25.4	120,500
SSC	125	27	25.4	140,600
SSC	125	28	25.4	140,600
SSC	125	29	25.4	148,800
SSC	125	30	25.4	148,800
SSC	125	3	31.75	58,800
SSC	125	4	31.75	58,800
SSC	125	5	31.75	56,300
SSC	125	6	31.75	56,300
SSC	125	7	31.75	56,300
SSC	125	8	31.75	56,300
SSC	125	9	31.75	60,400
SSC	125	10	31.75	60,400
SSC	125	11	31.75	66,400
SSC	125	12	31.75	66,400
SSC	125	13	31.75	69,600
SSC	125	14	31.75	72,600
SSC	125	15	31.75	78,500
SSC	125	16	31.75	78,500
SSC	125	17	31.75	86,600
SSC	125	18	31.75	86,600
SSC	125	19	31.75	100,600
SSC	125	20	31.75	100,600
SSC	125	22	31.75	106,100
SSC	125	24	31.75	112,400
SSC	125	25	31.75	118,600
SSC	125	26	31.75	120,500
SSC	125	28	31.75	140,600
SSC	125	30	31.75	148,800
SSC	150	3	25.4	88,000
SSC	150	3.5	25.4	88,000
SSC	150	4	25.4	88,000
SSC	150	4.5	25.4	80,400
SSC	150	5	25.4	80,400
SSC	150	5.5	25.4	80,400
SSC	150	6	25.4	80,400
SSC	150	6.5	25.4	80,400
SSC	150	7	25.4	80,400
SSC	150	7.5	25.4	80,400
SSC	150	8	25.4	80,400



(SSC)  
千鳥刃サイドカッター  
Side Milling Cutters, Staggered Tooth

SINCE 1935  
F.K.D.®

材質=HSS-Co

サイド刃高さ(H)

刃数

左右振れ角

刃径公差=0~+0.5

φ 75 10.5

φ 75 16枚

L ≤ 16 15°

φ 100 14

φ 100 18枚

16 < L < 25 12°

φ 125 16

φ 125 22枚

25 ≤ L 10°

刃幅公差

φ 150 18

φ 150 24枚

3 ~ 7 0~+0.05

φ 175 20

φ 175 26枚

7.5~11 0~+0.06

φ 200 22

φ 200 28枚

11.5~30 0~+0.07

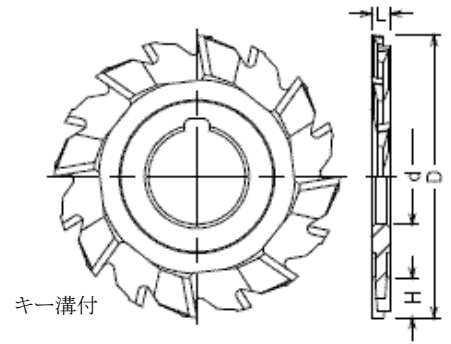

●注文例=型番、刃径、刃幅、穴径、数量「SSC 150x8.5x25.4」

型番	刃径 (D)	刃幅 (L)	穴径 (d)	標準価格
SSC	150	8.5	25.4	88,000
SSC	150	9	25.4	88,000
SSC	150	9.5	25.4	88,000
SSC	150	10	25.4	88,000
SSC	150	10.5	25.4	94,900
SSC	150	11	25.4	94,900
SSC	150	12	25.4	94,900
SSC	150	12.5	25.4	106,000
SSC	150	13	25.4	106,000
SSC	150	14	25.4	106,000
SSC	150	15	25.4	117,000
SSC	150	16	25.4	120,500
SSC	150	17	25.4	127,900
SSC	150	18	25.4	127,900
SSC	150	19	25.4	146,000
SSC	150	20	25.4	146,000
SSC	150	21	25.4	157,000
SSC	150	22	25.4	157,000
SSC	150	23	25.4	168,000
SSC	150	24	25.4	168,000
SSC	150	25	25.4	178,800
SSC	150	26	25.4	182,800
SSC	150	27	25.4	200,900
SSC	150	28	25.4	200,900
SSC	150	30	25.4	219,100
SSC	150	3	31.75	88,000
SSC	150	3.5	31.75	88,000
SSC	150	4	31.75	88,000
SSC	150	4.5	31.75	80,400
SSC	150	5	31.75	80,400
SSC	150	5.5	31.75	80,400
SSC	150	6	31.75	80,400
SSC	150	6.5	31.75	80,400
SSC	150	7	31.75	80,400
SSC	150	7.5	31.75	80,400
SSC	150	8	31.75	80,400
SSC	150	8.5	31.75	88,000
SSC	150	9	31.75	88,000
SSC	150	9.5	31.75	88,000
SSC	150	10	31.75	88,000
SSC	150	10.5	31.75	94,900
SSC	150	11	31.75	94,900
SSC	150	12	31.75	94,900

型番	刃径 (D)	刃幅 (L)	穴径 (d)	標準価格
SSC	150	12.5	31.75	106,000
SSC	150	13	31.75	106,000
SSC	150	14	31.75	106,000
SSC	150	15	31.75	117,000
SSC	150	16	31.75	120,500
SSC	150	17	31.75	127,900
SSC	150	18	31.75	127,900
SSC	150	19	31.75	146,000
SSC	150	20	31.75	146,000
SSC	150	22	31.75	157,000
SSC	150	24	31.75	168,000
SSC	150	25	31.75	178,800
SSC	150	26	31.75	182,800
SSC	150	28	31.75	200,900
SSC	150	30	31.75	219,100
SSC	175	4	25.4	160,700
SSC	175	5	25.4	160,700
SSC	175	6	25.4	146,000
SSC	175	7	25.4	146,000
SSC	175	8	25.4	140,600
SSC	175	9	25.4	140,600
SSC	175	10	25.4	140,600
SSC	175	11	25.4	148,100
SSC	175	12	25.4	148,100
SSC	175	13	25.4	155,200
SSC	175	14	25.4	162,600
SSC	175	15	25.4	175,400
SSC	175	16	25.4	175,400
SSC	175	17	25.4	195,600
SSC	175	18	25.4	195,600
SSC	175	19	25.4	220,900
SSC	175	20	25.4	220,900
SSC	175	22	25.4	233,600
SSC	175	24	25.4	246,500
SSC	175	25	25.4	257,400
SSC	175	26	25.4	266,600
SSC	175	28	25.4	273,600
SSC	175	30	25.4	281,200
SSC	175	4	31.75	160,700
SSC	175	5	31.75	160,700
SSC	175	6	31.75	146,000
SSC	175	7	31.75	146,000
SSC	175	8	31.75	140,600

# (SSC) 千鳥刃サイドカッター

Side Milling Cutters, Staggered Tooth

SINCE 1935  
F.K.D.®

材質=HSS-Co

サイド刃高さ(H)

刃数

左右振れ角

刃径公差=0~+0.5

φ 75 10.5

φ 75 16枚

L ≤ 16 15°

φ 100 14

φ 100 18枚

16 < L < 25 12°

φ 125 16

φ 125 22枚

25 ≤ L 10°

刃幅公差

φ 150 18

φ 150 24枚

3 ~ 7 0~+0.05

φ 175 20

φ 175 26枚

7.5~11 0~+0.06

φ 200 22

φ 200 28枚

11.5~30 0~+0.07

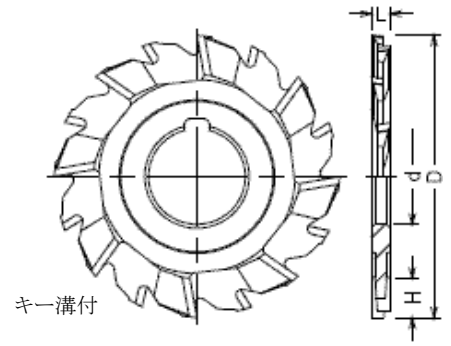

●注文例=型番、刃径、刃幅、穴径、数量「SSC 175x8x31.75」

型番	刃径 (D)	刃幅 (L)	穴径 (d)	標準価格
SSC	175	9	31.75	140,600
SSC	175	10	31.75	140,600
SSC	175	11	31.75	148,100
SSC	175	12	31.75	148,100
SSC	175	13	31.75	155,200
SSC	175	14	31.75	162,600
SSC	175	15	31.75	175,400
SSC	175	16	31.75	175,400
SSC	175	17	31.75	195,600
SSC	175	18	31.75	195,600
SSC	175	19	31.75	220,900
SSC	175	20	31.75	220,900
SSC	175	22	31.75	233,600
SSC	175	24	31.75	246,500
SSC	175	25	31.75	257,400
SSC	175	26	31.75	266,600
SSC	175	28	31.75	273,600
SSC	175	30	31.75	281,200
SSC	200	4	25.4	211,800
SSC	200	5	25.4	211,800
SSC	200	6	25.4	200,900
SSC	200	7	25.4	200,900
SSC	200	8	25.4	200,900
SSC	200	9	25.4	200,900
SSC	200	10	25.4	200,900
SSC	200	11	25.4	208,100
SSC	200	12	25.4	208,100
SSC	200	13	25.4	213,500
SSC	200	14	25.4	213,500
SSC	200	15	25.4	237,200
SSC	200	16	25.4	237,200
SSC	200	17	25.4	266,600
SSC	200	18	25.4	266,600
SSC	200	20	25.4	290,200
SSC	200	22	25.4	301,200
SSC	200	24	25.4	310,200
SSC	200	25	25.4	321,200
SSC	200	26	25.4	326,800
SSC	200	28	25.4	334,000
SSC	200	30	25.4	341,300
SSC	200	4	31.75	211,800
SSC	200	5	31.75	211,800

型番	刃径 (D)	刃幅 (L)	穴径 (d)	標準価格
SSC	200	6	31.75	200,900
SSC	200	7	31.75	200,900
SSC	200	8	31.75	200,900
SSC	200	9	31.75	200,900
SSC	200	10	31.75	200,900
SSC	200	11	31.75	208,100
SSC	200	12	31.75	208,100
SSC	200	13	31.75	213,500
SSC	200	14	31.75	213,500
SSC	200	15	31.75	237,200
SSC	200	16	31.75	237,200
SSC	200	17	31.75	266,600
SSC	200	18	31.75	266,600
SSC	200	20	31.75	290,200
SSC	200	22	31.75	301,200
SSC	200	24	31.75	310,200
SSC	200	25	31.75	321,200
SSC	200	26	31.75	326,800
SSC	200	28	31.75	334,000
SSC	200	30	31.75	341,300

○インチサイズ

●注文例=型番、刃径、刃幅、穴径、数量「SSC 75x1/4"x25.4」

型番	刃径 (D)	刃幅 (L)	穴径 (d)	標準価格
SSC	75	1/4"	25.4	22,100
SSC	75	3/8"	25.4	23,600
SSC	75	1/2"	25.4	29,400
SSC	100	1/4"	25.4	34,200
SSC	100	3/8"	25.4	36,700
SSC	100	1/2"	25.4	48,600
SSC	100	1/4"	31.75	34,200
SSC	100	1/2"	31.75	48,600
SSC	125	1/4"	25.4	56,300
SSC	125	3/8"	25.4	60,400
SSC	125	1/2"	25.4	69,600
SSC	125	1/2"	31.75	69,600
SSC	150	1/4"	25.4	80,400
SSC	150	3/8"	25.4	88,000
SSC	150	1/2"	25.4	106,000
SSC	150	1/2"	31.75	106,000
SSC	175	1/2"	25.4	155,200
SSC	175	1/2"	31.75	155,200

# (AC-RH) 右刃 シングルアングルカッター

Single Angle Cutters, Right Hand

SINCE 1935  
F.K.D.®

材質=HSS  
刃径公差=0~+1.0  
刃幅公差=±0.2  
角度公差=±15'

刃数  
φ 70 20枚  
φ 75 22枚  
φ 100 28枚  
φ 125 32枚  
φ 150 36枚

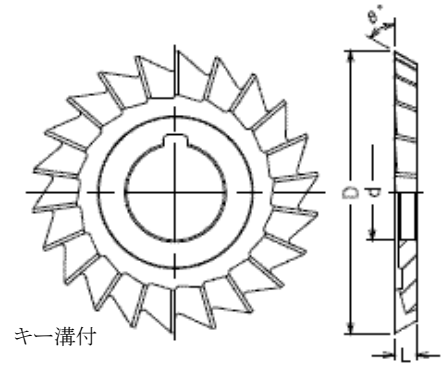

●注文例=型番、刃径、角度、刃幅、穴径、数量「AC-RH 30°x70x4x25.4」

型番	角度 (θ°)	刃径 (D)	刃幅 (L)	穴径 (d)	標準価格
AC-RH	30°	70	4	25.4	21,800
AC-RH		70	5	25.4	21,100
AC-RH		70	6	25.4	21,100
AC-RH		70	8	25.4	22,900
AC-RH		70	10	25.4	25,000
AC-RH		75	5	25.4	22,000
AC-RH		75	6	25.4	22,000
AC-RH		75	8	25.4	23,500
AC-RH		75	10	25.4	26,400
AC-RH		100	4	25.4	34,000
AC-RH		100	5	25.4	34,000
AC-RH		100	6	25.4	34,000
AC-RH		100	8	25.4	36,800
AC-RH		100	9	25.4	40,200
AC-RH		100	10	25.4	40,200
AC-RH		100	13	25.4	49,900
AC-RH	100	15	25.4	57,800	
AC-RH	35°	70	8	25.4	22,900
AC-RH		70	10	25.4	25,000
AC-RH		70	13	25.4	27,600
AC-RH		75	6	25.4	22,000
AC-RH		75	8	25.4	23,500
AC-RH		75	10	25.4	26,400
AC-RH		75	13	25.4	30,000
AC-RH		100	6	25.4	34,000
AC-RH		100	8	25.4	36,800
AC-RH		100	10	25.4	40,200
AC-RH	100	15	25.4	57,800	
AC-RH	40°	70	6	25.4	21,100
AC-RH		70	8	25.4	22,900
AC-RH		70	10	25.4	25,000
AC-RH		70	13	25.4	27,600
AC-RH		75	6	25.4	22,000
AC-RH		75	8	25.4	23,500
AC-RH		75	10	25.4	26,400
AC-RH		75	13	25.4	30,000
AC-RH		100	6	25.4	34,000
AC-RH		100	8	25.4	36,800
AC-RH	100	10	25.4	40,200	
AC-RH	100	15	25.4	57,800	
AC-RH	45°	70	4	25.4	20,200
AC-RH		70	6	25.4	19,300
AC-RH		70	8	25.4	20,900
AC-RH		70	10	25.4	23,200

型番	角度 (θ°)	刃径 (D)	刃幅 (L)	穴径 (d)	標準価格	
AC-RH	30°	70	11	25.4	25,200	
AC-RH		70	13	25.4	25,200	
AC-RH		70	15	25.4	31,000	
AC-RH		75	4	25.4	20,900	
AC-RH		75	6	25.4	20,300	
AC-RH		75	8	25.4	21,800	
AC-RH		75	10	25.4	24,200	
AC-RH		75	13	25.4	27,500	
AC-RH		75	15	25.4	31,300	
AC-RH		75	18	25.4	36,100	
AC-RH		75	20	25.4	43,100	
AC-RH		45°	100	4	25.4	31,300
AC-RH			100	6	25.4	31,300
AC-RH			100	8	25.4	33,500
AC-RH			100	10	25.4	37,000
AC-RH			100	13	25.4	45,800
AC-RH	100		15	25.4	53,300	
AC-RH	100		18	25.4	57,400	
AC-RH	100		20	25.4	61,700	
AC-RH	100		25	25.4	73,700	
AC-RH	100		30	25.4	107,500	
AC-RH	125		10	25.4	60,100	
AC-RH	125		13	25.4	74,300	
AC-RH	125		15	25.4	79,000	
AC-RH	125		20	25.4	105,500	
AC-RH	125	25	25.4	124,200		
AC-RH	125	30	25.4	143,300		
AC-RH	50°	150	15	25.4	115,000	
AC-RH		150	20	25.4	143,300	
AC-RH		150	25	25.4	164,400	
AC-RH		150	30	25.4	200,400	
AC-RH		70	10	25.4	25,000	
AC-RH		70	13	25.4	27,600	
AC-RH		70	15	25.4	33,500	
AC-RH		75	6	25.4	22,000	
AC-RH		75	8	25.4	23,500	
AC-RH		75	10	25.4	26,400	
AC-RH	75	13	25.4	30,000		
AC-RH	75	15	25.4	34,000		
AC-RH	75	18	25.4	39,500		
AC-RH	100	4	25.4	34,000		
AC-RH	100	6	25.4	34,000		
AC-RH	100	8	25.4	36,800		

# (AC-RH) 右刃 シングルアングルカッター

Single Angle Cutters, Right Hand

SINCE 1935  
F.K.D.®

材質=HSS

刃径公差=0~+1.0

刃幅公差=±0.2

角度公差=±15'

刃数

φ 70 20枚

φ 75 22枚

φ 100 28枚

φ 125 32枚

φ 150 36枚

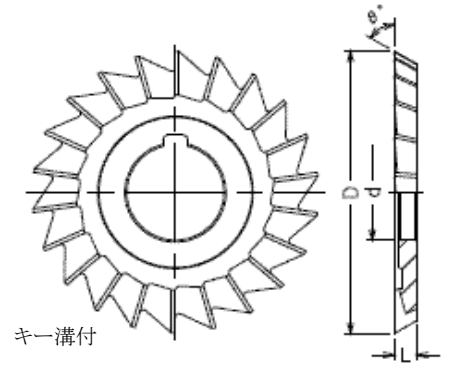

●注文例=型番、刃径、角度、刃幅、穴径、数量「AC-RH 50°x100x10x25.4」

型番	角度 (θ°)	刃径 (D)	刃幅 (L)	穴径 (d)	標準価格
AC-RH	50°	100	10	25.4	40,200
AC-RH		100	13	25.4	49,900
AC-RH		100	15	25.4	57,800
AC-RH		100	18	25.4	62,400
AC-RH		100	20	25.4	67,100
AC-RH		100	25	25.4	80,000
AC-RH		100	30	25.4	116,800
AC-RH		125	10	25.4	65,200
AC-RH		125	13	25.4	80,800
AC-RH		125	15	25.4	85,700
AC-RH		125	20	25.4	114,400
AC-RH		125	25	25.4	135,100
AC-RH		125	30	25.4	155,600
AC-RH		55°	70	10	25.4
AC-RH	70		13	25.4	27,600
AC-RH	70		15	25.4	33,500
AC-RH	75		4	25.4	22,900
AC-RH	75		6	25.4	22,000
AC-RH	75		8	25.4	23,500
AC-RH	75		10	25.4	26,400
AC-RH	75		13	25.4	30,000
AC-RH	75		15	25.4	34,000
AC-RH	75		18	25.4	39,500
AC-RH	75		20	25.4	46,900
AC-RH	75		25	25.4	57,400
AC-RH	100		4	25.4	34,000
AC-RH	100		6	25.4	34,000
AC-RH	100		8	25.4	36,800
AC-RH	100		10	25.4	40,200
AC-RH	100		13	25.4	49,900
AC-RH	100		15	25.4	57,800
AC-RH	100		18	25.4	62,400
AC-RH	100		20	25.4	67,100
AC-RH	125		10	25.4	65,200
AC-RH	125		13	25.4	80,800
AC-RH	125		15	25.4	85,700
AC-RH	125		20	25.4	114,400
AC-RH	60°	70	10	25.4	23,200
AC-RH		70	13	25.4	25,200
AC-RH		70	15	25.4	31,000
AC-RH		75	4	25.4	20,900
AC-RH		75	6	25.4	20,300
AC-RH		75	8	25.4	21,800

型番	角度 (θ°)	刃径 (D)	刃幅 (L)	穴径 (d)	標準価格	
AC-RH	60°	75	10	25.4	24,200	
AC-RH		75	13	25.4	27,500	
AC-RH		75	15	25.4	31,300	
AC-RH		75	18	25.4	36,100	
AC-RH		75	20	25.4	43,100	
AC-RH		75	25	25.4	52,600	
AC-RH		100	4	25.4	31,300	
AC-RH		100	6	25.4	31,300	
AC-RH		100	8	25.4	33,500	
AC-RH		100	10	25.4	37,000	
AC-RH		100	13	25.4	45,800	
AC-RH		100	15	25.4	53,300	
AC-RH		100	18	25.4	57,400	
AC-RH		100	20	25.4	61,700	
AC-RH	100	25	25.4	73,700		
AC-RH	100	30	25.4	107,500		
AC-RH	100	40	25.4	141,700		
AC-RH	100	50	25.4	174,500		
AC-RH	65°	125	10	25.4	60,100	
AC-RH		125	13	25.4	74,300	
AC-RH		125	15	25.4	79,000	
AC-RH		125	20	25.4	105,500	
AC-RH		125	25	25.4	124,200	
AC-RH		125	30	25.4	143,300	
AC-RH		150	15	25.4	115,000	
AC-RH		150	20	25.4	143,300	
AC-RH		150	25	25.4	164,400	
AC-RH		150	30	25.4	200,400	
AC-RH		70°	70	13	25.4	27,600
AC-RH			75	13	25.4	30,000
AC-RH			75	15	25.4	34,000
AC-RH			75	18	25.4	39,500
AC-RH	100		8	25.4	36,800	
AC-RH	100		10	25.4	40,200	
AC-RH	100		15	25.4	57,800	
AC-RH	100		18	25.4	62,400	
AC-RH	100		20	25.4	67,100	
AC-RH	100		25	25.4	80,000	

# (AC-RH) 右刃 シングルアングルカッター

Single Angle Cutters, Right Hand

SINCE 1935  
F.K.D.®

材質=HSS  
刃径公差=0~+1.0  
刃幅公差=±0.2  
角度公差=±15'

刃数  
φ 70 20枚  
φ 75 22枚  
φ 100 28枚  
φ 125 32枚  
φ 150 36枚

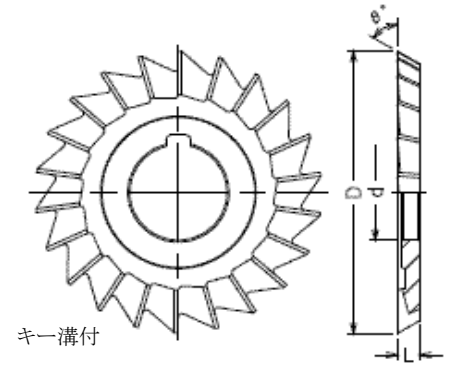

●注文例=型番、刃径、角度、刃幅、穴径、数量「AC-RH 70°x100x15x25.4」

型番	角度 (θ°)	刃径 (D)	刃幅 (L)	穴径 (d)	標準価格
AC-RH	70°	100	15	25.4	57,800
AC-RH		100	18	25.4	62,400
AC-RH		100	20	25.4	67,100
AC-RH	75°	70	13	25.4	27,600
AC-RH		70	15	25.4	33,500
AC-RH		75	13	25.4	30,000
AC-RH		75	15	25.4	34,000
AC-RH		75	18	25.4	39,500
AC-RH		75	20	25.4	46,900
AC-RH		100	6	25.4	34,000
AC-RH		100	8	25.4	36,800
AC-RH		100	10	25.4	40,200
AC-RH		100	15	25.4	57,800
AC-RH		100	18	25.4	62,400

型番	角度 (θ°)	刃径 (D)	刃幅 (L)	穴径 (d)	標準価格
AC-RH	75°	100	20	25.4	67,100
AC-RH		125	10	25.4	65,200
AC-RH		125	15	25.4	85,700
AC-RH		125	20	25.4	114,400
AC-RH	80°	70	20	25.4	36,800
AC-RH		75	13	25.4	30,000
AC-RH		75	15	25.4	34,000
AC-RH		75	18	25.4	39,500
AC-RH		100	8	25.4	36,800
AC-RH		100	10	25.4	40,200
AC-RH		100	15	25.4	57,800
AC-RH		100	18	25.4	62,400
AC-RH		100	20	25.4	67,100

# (AC-LH)左刃 シングルアングルカッター

Single Angle Cutters, Left Hand

SINCE 1935  
F.K.D.®

材質=HSS  
刃径公差=0~+1.0  
刃幅公差=±0.2  
角度公差=±15'

刃数  
φ 70 20枚  
φ 75 22枚  
φ 100 28枚  
φ 125 32枚  
φ 150 36枚

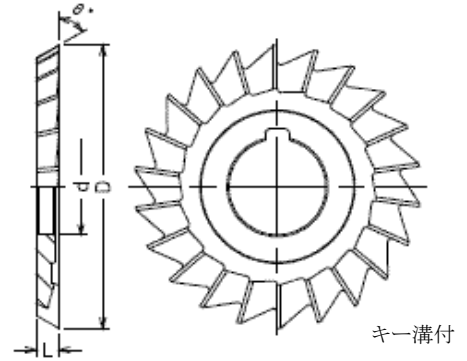

●注文例=型番、刃径、角度、刃幅、穴径、数量「AC-LH 30°x70x4x25.4」

型番	角度 (θ°)	刃径 (D)	刃幅 (L)	穴径 (d)	標準価格
AC-LH	30°	70	4	25.4	21,800
AC-LH		70	5	25.4	21,100
AC-LH		70	6	25.4	21,100
AC-LH		70	8	25.4	22,900
AC-LH		70	10	25.4	25,000
AC-LH		75	5	25.4	22,000
AC-LH		75	6	25.4	22,000
AC-LH		75	8	25.4	23,500
AC-LH		75	9	25.4	26,400
AC-LH		75	10	25.4	26,400
AC-LH		100	4	25.4	34,000
AC-LH		100	6	25.4	34,000
AC-LH		100	8	25.4	36,800
AC-LH		100	10	25.4	40,200
AC-LH		100	13	25.4	49,900
AC-LH	100	15	25.4	57,800	
AC-LH	35°	70	8	25.4	22,900
AC-LH		70	10	25.4	25,000
AC-LH		70	13	25.4	27,600
AC-LH		75	6	25.4	22,000
AC-LH		75	8	25.4	23,500
AC-LH		75	10	25.4	26,400
AC-LH		75	13	25.4	30,000
AC-LH		100	6	25.4	34,000
AC-LH		100	8	25.4	36,800
AC-LH		100	10	25.4	40,200
AC-LH		100	15	25.4	57,800
AC-LH		40°	70	6	25.4
AC-LH	70		8	25.4	22,900
AC-LH	70		10	25.4	25,000
AC-LH	70		13	25.4	27,600
AC-LH	75		6	25.4	22,000
AC-LH	75		8	25.4	23,500
AC-LH	75		10	25.4	26,400
AC-LH	75		13	25.4	30,000
AC-LH	100		6	25.4	34,000
AC-LH	100		8	25.4	36,800
AC-LH	100		10	25.4	40,200
AC-LH	100		15	25.4	57,800
AC-LH	45°	70	4	25.4	20,200
AC-LH		70	6	25.4	19,300
AC-LH		70	8	25.4	20,900
AC-LH		70	10	25.4	23,200

型番	角度 (θ°)	刃径 (D)	刃幅 (L)	穴径 (d)	標準価格	
AC-LH	30°	70	11	25.4	25,200	
AC-LH		70	13	25.4	25,200	
AC-LH		70	15	25.4	31,000	
AC-LH		75	4	25.4	20,900	
AC-LH		75	6	25.4	20,300	
AC-LH		75	8	25.4	21,800	
AC-LH		75	10	25.4	24,200	
AC-LH		75	13	25.4	27,500	
AC-LH		75	15	25.4	31,300	
AC-LH		75	18	25.4	36,100	
AC-LH		75	20	25.4	43,100	
AC-LH		45°	100	4	25.4	31,300
AC-LH			100	6	25.4	31,300
AC-LH			100	8	25.4	33,500
AC-LH			100	10	25.4	37,000
AC-LH	100		13	25.4	45,800	
AC-LH	100		15	25.4	53,300	
AC-LH	100		18	25.4	57,400	
AC-LH	100		20	25.4	61,700	
AC-LH	100		25	25.4	73,700	
AC-LH	100		30	25.4	107,500	
AC-LH	125		10	25.4	60,100	
AC-LH	125		13	25.4	74,300	
AC-LH	125		15	25.4	79,000	
AC-LH	125		20	25.4	105,500	
AC-LH	125		25	25.4	124,200	
AC-LH	125	30	25.4	143,300		
AC-LH	50°	150	15	25.4	115,000	
AC-LH		150	20	25.4	143,300	
AC-LH		150	25	25.4	164,400	
AC-LH		150	30	25.4	200,400	
AC-LH		70	10	25.4	25,000	
AC-LH		70	13	25.4	27,600	
AC-LH		70	15	25.4	33,500	
AC-LH		75	6	25.4	22,000	
AC-LH		75	8	25.4	23,500	
AC-LH		75	10	25.4	26,400	
AC-LH		75	13	25.4	30,000	
AC-LH		75	15	25.4	34,000	
AC-LH		75	18	25.4	39,500	
AC-LH		100	4	25.4	34,000	
AC-LH		100	6	25.4	34,000	
AC-LH	100	8	25.4	36,800		

# (AC-LH)左刃 シングルアングルカッター

Single Angle Cutters, Left Hand

SINCE 1935  
F.K.D.®

材質=HSS

刃径公差=0~+1.0

刃幅公差=±0.2

角度公差=±15'

刃数

φ 70 20枚

φ 75 22枚

φ 100 28枚

φ 125 32枚

φ 150 36枚

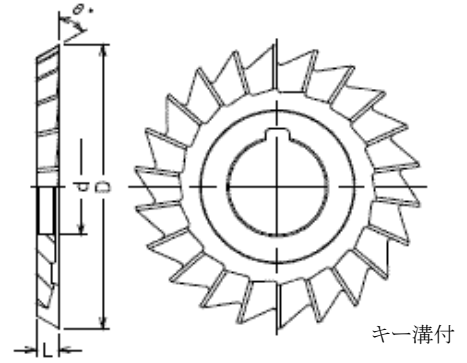

●注文例=型番、刃径、角度、刃幅、穴径、数量「AC-LH 50°x100x10x25.4」

型番	角度 (θ°)	刃径 (D)	刃幅 (L)	穴径 (d)	標準価格
AC-LH	50°	100	10	25.4	40,200
AC-LH		100	13	25.4	49,900
AC-LH		100	15	25.4	57,800
AC-LH		100	18	25.4	62,400
AC-LH		100	20	25.4	67,100
AC-LH		100	25	25.4	80,000
AC-LH		100	30	25.4	116,800
AC-LH		125	10	25.4	65,200
AC-LH		125	13	25.4	80,800
AC-LH		125	15	25.4	85,700
AC-LH		125	20	25.4	114,400
AC-LH		125	25	25.4	135,100
AC-LH		125	30	25.4	155,600
AC-LH		55°	70	10	25.4
AC-LH	70		13	25.4	27,600
AC-LH	70		15	25.4	33,500
AC-LH	75		4	25.4	22,900
AC-LH	75		6	25.4	22,000
AC-LH	75		8	25.4	23,500
AC-LH	75		10	25.4	26,400
AC-LH	75		13	25.4	30,000
AC-LH	75		15	25.4	34,000
AC-LH	75		18	25.4	39,500
AC-LH	75		20	25.4	46,900
AC-LH	75		25	25.4	57,400
AC-LH	100		4	25.4	34,000
AC-LH	100		6	25.4	34,000
AC-LH	100		8	25.4	36,800
AC-LH	100		10	25.4	40,200
AC-LH	100		13	25.4	49,900
AC-LH	100		15	25.4	57,800
AC-LH	100		18	25.4	62,400
AC-LH	100		20	25.4	67,100
AC-LH	125		10	25.4	65,200
AC-LH	125		13	25.4	80,800
AC-LH	125		15	25.4	85,700
AC-LH	125		20	25.4	114,400
AC-LH	60°	70	10	25.4	23,200
AC-LH		70	13	25.4	25,200
AC-LH		70	15	25.4	31,000
AC-LH		75	4	25.4	20,900
AC-LH		75	6	25.4	20,300
AC-LH		75	8	25.4	21,800

型番	角度 (θ°)	刃径 (D)	刃幅 (L)	穴径 (d)	標準価格
AC-LH	60°	75	10	25.4	24,200
AC-LH		75	13	25.4	27,500
AC-LH		75	15	25.4	31,300
AC-LH		75	18	25.4	36,100
AC-LH		75	20	25.4	43,100
AC-LH		75	25	25.4	52,600
AC-LH		100	4	25.4	31,300
AC-LH		100	6	25.4	31,300
AC-LH		100	8	25.4	33,500
AC-LH		100	10	25.4	37,000
AC-LH		100	13	25.4	45,800
AC-LH		100	15	25.4	53,300
AC-LH		100	18	25.4	57,400
AC-LH		100	20	25.4	61,700
AC-LH	100	25	25.4	73,700	
AC-LH	100	30	25.4	107,500	
AC-LH	100	40	25.4	141,700	
AC-LH	125	10	25.4	60,100	
AC-LH	125	13	25.4	74,300	
AC-LH	125	15	25.4	79,000	
AC-LH	125	20	25.4	105,500	
AC-LH	125	25	25.4	124,200	
AC-LH	125	30	25.4	143,300	
AC-LH	150	15	25.4	115,000	
AC-LH	150	20	25.4	143,300	
AC-LH	150	25	25.4	164,400	
AC-LH	150	30	25.4	200,400	
AC-LH	65°	70	13	25.4	27,600
AC-LH		75	13	25.4	30,000
AC-LH		75	15	25.4	34,000
AC-LH		75	18	25.4	39,500
AC-LH		100	8	25.4	36,800
AC-LH		100	10	25.4	40,200
AC-LH		100	15	25.4	57,800
AC-LH		100	18	25.4	62,400
AC-LH	100	20	25.4	67,100	
AC-LH	70°	70	10	25.4	25,000
AC-LH		70	13	25.4	27,600
AC-LH		75	13	25.4	30,000
AC-LH		75	15	25.4	34,000
AC-LH		75	18	25.4	39,500
AC-LH		100	8	25.4	36,800
AC-LH		100	10	25.4	40,200
AC-LH		100	15	25.4	57,800

# (AC-LH)左刃 シングルアングルカッター

Single Angle Cutters, Left Hand

SINCE 1935  
F.K.D.®

材質=HSS  
刃径公差=0~+1.0  
刃幅公差=±0.2  
角度公差=±15'

刃数  
φ 70 20枚  
φ 75 22枚  
φ 100 28枚  
φ 125 32枚  
φ 150 36枚

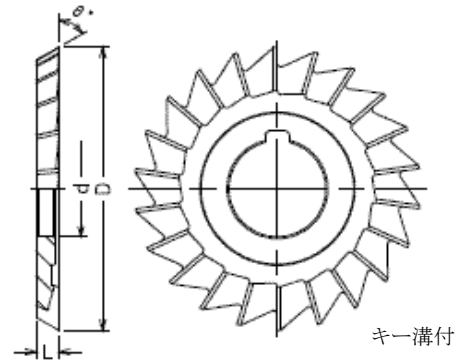

●注文例=型番、刃径、角度、刃幅、穴径、数量「AC-LH 70°x100x18x25.4」

型番	角度 (θ°)	刃径 (D)	刃幅 (L)	穴径 (d)	標準価格
AC-LH	70°	100	18	25.4	62,400
AC-LH		100	20	25.4	67,100
AC-LH	75°	70	13	25.4	27,600
AC-LH		70	15	25.4	33,500
AC-LH		75	13	25.4	30,000
AC-LH		75	15	25.4	34,000
AC-LH		75	18	25.4	39,500
AC-LH		75	20	25.4	46,900
AC-LH		100	6	25.4	34,000
AC-LH		100	8	25.4	36,800
AC-LH		100	10	25.4	40,200
AC-LH		100	15	25.4	57,800
AC-LH	100	18	25.4	62,400	

型番	角度 (θ°)	刃径 (D)	刃幅 (L)	穴径 (d)	標準価格
AC-LH	75°	100	20	25.4	67,100
AC-LH		125	10	25.4	65,200
AC-LH		125	15	25.4	85,700
AC-LH		125	20	25.4	114,400
AC-LH	80°	70	20	25.4	36,800
AC-LH		75	13	25.4	30,000
AC-LH		75	15	25.4	34,000
AC-LH		75	18	25.4	39,500
AC-LH		100	8	25.4	36,800
AC-LH		100	10	25.4	40,200
AC-LH		100	15	25.4	57,800
AC-LH		100	18	25.4	62,400
AC-LH		100	20	25.4	67,100



# (WAC) ダブルアングルカッター

Double Angle Cutters

SINCE 1935  
F.K.D.®

材質=HSS  
刃径公差=0~+1.0  
刃幅公差=±0.2  
角度公差=±15'

刃数  
φ 70 20枚  
φ 75 22枚  
φ 100 28枚  
φ 125 32枚  
φ 150 36枚

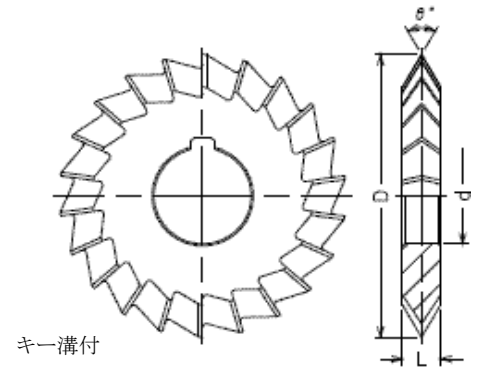

キー溝付

●注文例=型番、角度、刃径、刃幅、穴径、数量「WAC 30°x70x6x25.4」

型番	角度 (θ°)	刃径 (D)	刃幅 (L)	穴径 (d)	標準価格	
WAC	30°	70	6	25.4	21,100	
WAC		70	8	25.4	22,900	
WAC		70	10	25.4	25,000	
WAC		75	4	25.4	22,900	
WAC		75	6	25.4	22,000	
WAC		75	8	25.4	23,500	
WAC		75	10	25.4	26,400	
WAC		100	6	25.4	34,000	
WAC		100	8	25.4	36,800	
WAC		100	10	25.4	40,200	
WAC		100	13	25.4	49,900	
WAC		100	15	25.4	57,800	
WAC		35°	70	10	25.4	25,000
WAC			75	10	25.4	26,400
WAC	75		13	25.4	30,000	
WAC	100		6	25.4	34,000	
WAC	100		8	25.4	36,800	
WAC	100		10	25.4	40,200	
WAC	40°	100	15	25.4	57,800	
WAC		70	10	25.4	25,000	
WAC		70	13	25.4	27,600	
WAC		75	6	25.4	22,000	
WAC		100	6	25.4	34,000	
WAC		100	8	25.4	36,800	
WAC		100	10	25.4	40,200	
WAC	45°	100	15	25.4	57,800	
WAC		70	10	25.4	23,200	
WAC		70	13	25.4	25,200	
WAC		75	4	25.4	20,900	
WAC		75	6	25.4	20,300	
WAC		75	8	25.4	21,800	
WAC		75	10	25.4	24,200	
WAC		75	13	25.4	27,500	
WAC		75	15	25.4	31,300	
WAC		75	18	25.4	36,100	
WAC		100	4	25.4	31,300	
WAC		100	6	25.4	31,300	
WAC		100	8	25.4	33,500	
WAC		100	10	25.4	37,000	
WAC		100	13	25.4	45,800	
WAC		100	15	25.4	53,300	
WAC		100	18	25.4	57,400	
WAC		100	20	25.4	61,700	

型番	角度 (θ°)	刃径 (D)	刃幅 (L)	穴径 (d)	標準価格
WAC	45°	100	25	25.4	73,700
WAC		125	10	25.4	60,100
WAC		125	15	25.4	79,000
WAC		125	20	25.4	105,500
WAC		125	25	25.4	124,200
WAC		50°	70	13	25.4
WAC	75		8	25.4	23,500
WAC	75		10	25.4	26,400
WAC	75		13	25.4	30,000
WAC	75		18	25.4	39,500
WAC	75		20	25.4	46,900
WAC	100		8	25.4	36,800
WAC	100		10	25.4	40,200
WAC	100		15	25.4	57,800
WAC	100		20	25.4	67,100
WAC	125		10	25.4	65,200
WAC	125		20	25.4	114,400
WAC	55°	70	13	25.4	27,600
WAC		75	8	25.4	23,500
WAC		75	10	25.4	26,400
WAC		75	13	25.4	30,000
WAC		75	18	25.4	39,500
WAC		75	20	25.4	46,900
WAC		100	8	25.4	36,800
WAC		100	10	25.4	40,200
WAC		100	15	25.4	57,800
WAC		100	20	25.4	67,100
WAC	60°	125	10	25.4	65,200
WAC		125	15	25.4	85,700
WAC		125	20	25.4	114,400
WAC		70	10	25.4	23,200
WAC		70	13	25.4	25,200
WAC		75	4	25.4	20,900
WAC		75	6	25.4	20,300
WAC		75	8	25.4	21,800
WAC		75	10	25.4	24,200
WAC		75	13	25.4	27,500
WAC		75	15	25.4	31,300
WAC		75	18	25.4	36,100
WAC	100	4	25.4	31,300	
WAC	100	6	25.4	31,300	

# (WAC) ダブルアングルカッター

Double Angle Cutters

SINCE 1935  
F.K.D.®

材質=HSS  
刃径公差=0~+1.0  
刃幅公差=±0.2  
角度公差=±15'

刃数  
φ 70 20枚  
φ 75 22枚  
φ 100 28枚  
φ 125 32枚  
φ 150 36枚

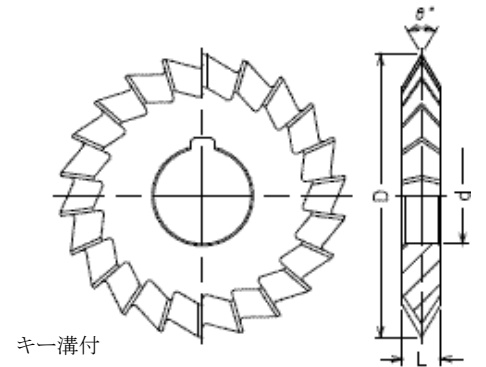

●注文例=型番、角度、刃径、刃幅、穴径、数量「WAC 60°x100x8x25.4」

型番	角度 (θ°)	刃径 (D)	刃幅 (L)	穴径 (d)	標準価格
WAC	60°	100	8	25.4	33,500
WAC		100	10	25.4	37,000
WAC		100	13	25.4	45,800
WAC		100	15	25.4	53,300
WAC		100	18	25.4	57,400
WAC		100	20	25.4	61,700
WAC		100	25	25.4	73,700
WAC		125	10	25.4	60,100
WAC		125	15	25.4	79,000
WAC		125	20	25.4	105,500
WAC		125	25	25.4	124,200
WAC		125	30	25.4	143,300
WAC		150	13	25.4	110,200
WAC		150	15	25.4	115,000
WAC		150	20	25.4	143,300
WAC		65°	70	13	25.4
WAC	75		13	25.4	30,000
WAC	75		15	25.4	34,000
WAC	75		18	25.4	39,500
WAC	100		6	25.4	34,000
WAC	100		8	25.4	36,800
WAC	100		10	25.4	40,200
WAC	100		15	25.4	57,800
WAC	100		20	25.4	67,100
WAC	125		10	25.4	65,200
WAC	125		15	25.4	85,700
WAC	125		20	25.4	114,400
WAC	70°	70	13	25.4	27,600
WAC		75	13	25.4	30,000
WAC		75	15	25.4	34,000
WAC		75	18	25.4	39,500
WAC		75	20	25.4	46,900
WAC		100	4	25.4	34,000
WAC		100	6	25.4	34,000
WAC		100	8	25.4	36,800
WAC		100	10	25.4	40,200
WAC		100	15	25.4	57,800
WAC		100	18	25.4	62,400
WAC		100	20	25.4	67,100
WAC	125	10	25.4	65,200	
WAC	125	15	25.4	85,700	
WAC	125	20	25.4	114,400	
WAC	75°	70	13	25.4	27,600

型番	角度 (θ°)	刃径 (D)	刃幅 (L)	穴径 (d)	標準価格
WAC	75°	75	13	25.4	30,000
WAC		75	15	25.4	34,000
WAC		75	18	25.4	39,500
WAC		75	20	25.4	46,900
WAC		100	6	25.4	34,000
WAC		100	8	25.4	36,800
WAC		100	10	25.4	40,200
WAC		100	15	25.4	57,800
WAC		100	18	25.4	62,400
WAC		100	20	25.4	67,100
WAC		125	10	25.4	65,200
WAC		125	15	25.4	85,700
WAC	125	20	25.4	114,400	
WAC	80°	75	10	25.4	26,400
WAC		75	13	25.4	30,000
WAC		75	15	25.4	34,000
WAC		75	18	25.4	39,500
WAC		75	20	25.4	46,900
WAC		100	4	25.4	34,000
WAC		100	6	25.4	34,000
WAC		100	8	25.4	36,800
WAC		100	10	25.4	40,200
WAC		100	15	25.4	57,800
WAC		100	18	25.4	62,400
WAC		100	20	25.4	67,100
WAC	125	10	25.4	65,200	
WAC	125	15	25.4	85,700	
WAC	125	20	25.4	114,400	
WAC	90°	70	6	25.4	19,300
WAC		70	8	25.4	20,900
WAC		70	10	25.4	23,200
WAC		70	13	25.4	25,200
WAC		75	4	25.4	20,900
WAC		75	6	25.4	20,300
WAC		75	8	25.4	21,800
WAC		75	10	25.4	24,200
WAC		75	13	25.4	27,500
WAC		75	15	25.4	31,300
WAC		75	18	25.4	36,100
WAC		75	20	25.4	43,100
WAC	75	25	25.4	52,600	
WAC	100	4	25.4	31,300	
WAC	100	6	25.4	31,300	

# (WAC) ダブルアングルカッター

Double Angle Cutters

SINCE 1935  
F.K.D.®

材質=HSS  
刃径公差=0~+1.0  
刃幅公差=±0.2  
角度公差=±15'

刃数  
φ 70 20枚  
φ 75 22枚  
φ 100 28枚  
φ 125 32枚  
φ 150 36枚

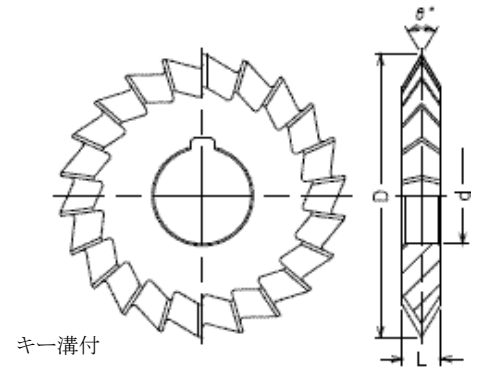

キー溝付

●注文例=型番、角度、刃径、刃幅、穴径、数量「WAC 90°x100x18x25.4」

型番	角度 (θ°)	刃径 (D)	刃幅 (L)	穴径 (d)	標準価格	
WAC	90°	100	8	25.4	33,500	
WAC		100	10	25.4	37,000	
WAC		100	15	25.4	53,300	
WAC		100	18	25.4	57,400	
WAC		100	20	25.4	61,700	
WAC		100	25	25.4	73,700	
WAC		100	30	25.4	107,500	
WAC		100	40	25.4	141,700	
WAC		100	50	25.4	174,500	
WAC		125	10	25.4	60,100	
WAC		125	15	25.4	79,000	
WAC		125	20	25.4	105,500	
WAC		125	25	25.4	124,200	
WAC		125	30	25.4	143,300	
WAC		150	15	25.4	115,000	
WAC		150	20	25.4	143,300	
WAC		150	25	25.4	164,400	
WAC		150	30	25.4	200,600	
WAC		100°	70	13	25.4	27,600
WAC			75	6	25.4	22,000
WAC	75		8	25.4	23,500	
WAC	75		10	25.4	26,400	
WAC	75		13	25.4	30,000	
WAC	75		15	25.4	34,000	
WAC	75		18	25.4	39,500	
WAC	75		20	25.4	46,900	
WAC	100		6	25.4	34,000	
WAC	100		8	25.4	36,800	
WAC	100		10	25.4	40,200	
WAC	100		15	25.4	57,800	
WAC	100		18	25.4	62,400	
WAC	100		20	25.4	67,100	
WAC	125		10	25.4	65,200	
WAC	125		15	25.4	85,700	
WAC	125		20	25.4	114,400	

型番	角度 (θ°)	刃径 (D)	刃幅 (L)	穴径 (d)	標準価格
WAC	110°	70	13	25.4	27,600
WAC		75	6	25.4	22,000
WAC		75	8	25.4	23,500
WAC		75	13	25.4	30,000
WAC		75	15	25.4	34,000
WAC		75	18	25.4	39,500
WAC		100	10	25.4	40,200
WAC		100	20	25.4	67,100
WAC		125	10	25.4	65,200
WAC		125	15	25.4	85,700
WAC		125	20	25.4	114,400
WAC		120°	70	10	25.4
WAC	70		13	25.4	25,200
WAC	75		4	25.4	20,900
WAC	75		6	25.4	20,300
WAC	75		8	25.4	21,800
WAC	75		10	25.4	24,200
WAC	75		13	25.4	27,500
WAC	75		15	25.4	31,300
WAC	75		18	25.4	36,100
WAC	75		20	25.4	43,100
WAC	75		25	25.4	52,600
WAC	100		4	25.4	31,300
WAC	100		6	25.4	31,300
WAC	100		8	25.4	33,500
WAC	100		10	25.4	37,000
WAC	100		15	25.4	53,300
WAC	100		18	25.4	57,400
WAC	100		20	25.4	61,700
WAC	100		25	25.4	73,700
WAC	100		30	25.4	107,500
WAC	125		10	25.4	60,100
WAC	125		15	25.4	79,000
WAC	125		20	25.4	105,500
WAC	125		25	25.4	124,200
WAC	150	15	25.4	115,000	
WAC	150	20	25.4	143,300	
WAC	150	25	25.4	164,400	
WAC	150	30	25.4	200,400	

# 3Sストレートシャンクドリル

3S Straight Shank Drills

SINCE 1935  
F.K.D.®

## 特定代理店在庫

材質=HSS  
直径公差=0~-0.04  
シャンク公差=h8

## (SRM) R型 [六角穴付きボルト用(キャップボルト)]

円錐・S-X形シンニング

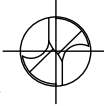

型番	呼び記号	先端直径 (Dc1)	2段目直径 (Dc2)	ステップ長 (ℓ1)	溝長 (ℓ)	全長 (L)	シャンク径 (Ds)	標準定価
SRM	M3	3.4	6.5	13	25	65	6	3,600
SRM	M4	4.5	8	18	35	75	6	3,900
SRM	M5	5.5	9.5	22	40	85	8	4,100
SRM	M6	6.6	11	25	45	90	8	5,100
SRM	M8	9	14	28	55	100	12	6,400
SRM	M10	11	17.5	30	60	110	12	7,500
SRM	M12	14	20	32	65	115	12	10,500
SRM	M14	16	23	35	75	125	12	12,500
SRM	M16	18	26	40	85	135	12	14,500
SRM	M18	20	29	45	95	145	12	16,300
SRM	1/4"	6.9	11	25	45	90	8	6,000
SRM	5/16"	8.9	14	28	55	100	12	7,700
SRM	3/8"	10.5	15	30	60	110	12	9,200
SRM	1/2"	14.7	20	32	65	115	12	13,100
SRM	5/8"	17.9	26	40	85	135	12	18,100

※ 特定代理店のみの扱いです。



## 特定代理店在庫

材質=HSS  
直径公差=0~-0.04  
シャンク公差=h8

## (SSM) S型 [皿小ねじ用]

円錐・S-X形シンニング

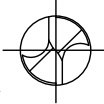

型番	呼び記号	先端直径 (Dc1)	2段目直径 (Dc2)	ステップ長 (ℓ1)	溝長 (ℓ)	全長 (L)	シャンク径 (Ds)	標準定価
SSM	M3	3.4	6.4	13	25	65	6	3,600
SSM	M4	4.5	8.4	18	30	70	6	3,900
SSM	M5	5.5	10.4	22	35	80	8	4,800
SSM	M6	6.6	12.5	25	40	85	10	5,600
SSM	M8	9	16.5	28	45	90	12	7,600
SSM	M10	11	21	36	50	95	12	12,700
SSM	M12	14	25	39.5	75	120	12	15,500

※ 特定代理店のみの扱いです。

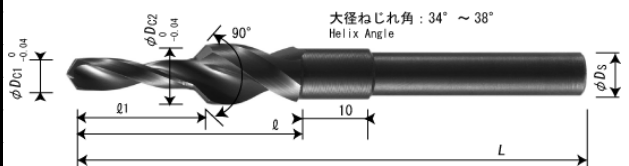

## 特定代理店在庫

材質=HSS  
直径公差=0~-0.04  
シャンク公差=h8

## (SHM) H型 [平小ねじ用]

円錐・S-X形シンニング

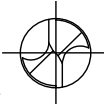

型番	呼び記号	先端直径 (Dc1)	2段目直径 (Dc2)	ステップ長 (ℓ1)	溝長 (ℓ)	全長 (L)	シャンク径 (Ds)	標準定価
SHM	M3	3.4	5.9	13	25	65	6	3,500
SHM	M4	4.5	7.4	18	35	75	6	3,800
SHM	M5	5.5	9.4	22	40	85	8	4,100
SHM	M6	6.6	11	25	45	90	8	5,100
SHM	M8	9	14.5	28	55	100	12	6,400

※ 特定代理店のみの扱いです。

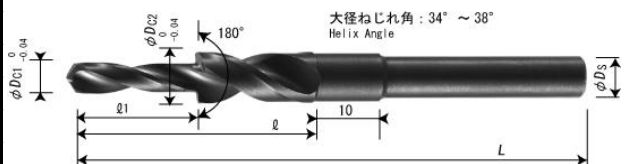

(SD)  
超硬付刃ストレートシャンクドリル  
Straight Shank Drills, G-2 Carbide Tipped

SINCE 1935  
F.K.D.®

材質=G2 (ロー付タイプ)  
リード角=右振り20°  
刃径公差=0~-0.03

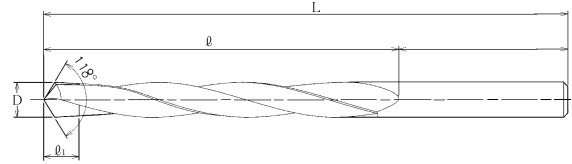

●注文例=型番、刃径、数量「SD 3」

型番	刃径 (D)	溝長 (l)	全長 (L)	標準価格
SD	3	43	75	6,500
SD	3.1	43	75	6,500
SD	3.2	43	75	6,500
SD	3.3	43	75	6,500
SD	3.4	43	75	6,500
SD	3.5	47	80	6,500
SD	3.6	47	80	6,500
SD	3.7	47	80	6,500
SD	3.8	47	80	6,500
SD	3.9	47	80	6,500
SD	4	55	88	6,500
SD	4.1	55	88	6,500
SD	4.2	55	88	6,500
SD	4.3	55	88	6,500
SD	4.4	55	88	6,500
SD	4.5	57	92	6,500
SD	4.6	57	92	6,500
SD	4.7	57	92	6,500
SD	4.8	57	92	6,500
SD	4.9	57	92	6,500
SD	5	60	95	6,500
SD	5.1	60	95	6,500
SD	5.2	60	95	6,500
SD	5.3	60	95	6,500
SD	5.4	60	95	6,500
SD	5.5	63	100	6,500
SD	5.6	63	100	6,700
SD	5.7	63	100	6,700
SD	5.8	63	100	6,700
SD	5.9	63	100	6,700
SD	6	67	105	6,700
SD	6.1	67	105	6,700
SD	6.2	67	105	6,700
SD	6.3	67	105	6,700
SD	6.4	67	105	6,700
SD	6.5	70	108	6,700
SD	6.6	70	108	7,000
SD	6.7	70	108	7,000
SD	6.8	70	108	7,000
SD	6.9	70	108	7,000
SD	7	75	112	7,000
SD	7.1	75	112	7,000
SD	7.2	75	112	7,000
SD	7.3	75	112	7,000
SD	7.4	75	112	7,000
SD	7.5	77	115	7,000
SD	7.6	77	115	7,800
SD	7.7	77	115	7,800
SD	7.8	77	115	7,800
SD	7.9	77	115	7,800

型番	刃径 (D)	溝長 (l)	全長 (L)	標準価格
SD	8	80	118	7,800
SD	8.1	80	118	7,800
SD	8.2	80	118	7,800
SD	8.3	80	118	7,800
SD	8.4	80	118	7,800
SD	8.5	83	122	7,800
SD	8.6	83	122	8,700
SD	8.7	83	122	8,700
SD	8.8	83	122	8,700
SD	8.9	83	122	8,700
SD	9	85	125	8,700
SD	9.1	85	125	8,700
SD	9.2	85	125	8,700
SD	9.3	85	125	8,700
SD	9.4	85	125	8,700
SD	9.5	90	130	8,700
SD	9.6	90	130	9,600
SD	9.7	90	130	9,600
SD	9.8	90	130	9,600
SD	9.9	90	130	9,600
SD	10	95	135	9,600
SD	10.1	95	135	9,600
SD	10.2	95	135	9,600
SD	10.3	95	135	9,600
SD	10.4	95	135	9,600
SD	10.5	100	140	9,600
SD	10.6	100	140	10,000
SD	10.7	100	140	10,000
SD	10.8	100	140	10,000
SD	10.9	100	140	10,000
SD	11	103	145	10,000
SD	11.1	103	145	10,000
SD	11.2	103	145	10,000
SD	11.3	103	145	10,000
SD	11.4	103	145	10,000
SD	11.5	105	150	10,000
SD	11.6	105	150	10,500
SD	11.7	105	150	10,500
SD	11.8	105	150	10,500
SD	11.9	105	150	10,500
SD	12	105	155	10,500
SD	12.1	105	155	10,500
SD	12.2	105	155	10,500
SD	12.3	105	155	10,500
SD	12.4	105	155	10,500
SD	12.5	105	155	10,500
SD	12.6	105	155	11,000
SD	12.7	105	155	11,000
SD	12.8	105	155	11,000
SD	12.9	105	155	11,000
SD	13	105	155	11,000

(TD)  
超硬付刃テーパシャンクドリル  
Taper Shank Drills, G-2 Carbide Tipped



材質=G2 (ロー付タイプ)  
リード角=右戻れ20°

刃径公差  
D ≤ 18 0 ~ -0.030  
18 < D ≤ 29 0 ~ -0.033  
29 < D ≤ 60 0 ~ -0.039

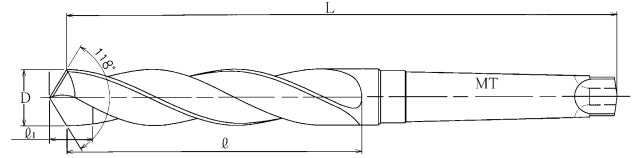
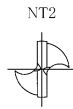

●注文例=型番、刃径、数量 「TD 6」

型番	刃径 (D)	溝長 (ℓ)	全長 (L)	シャンク	標準価格
TD	6	30	110	MT1	16,700
TD	6.5	40	120	MT1	16,700
TD	7	40	120	MT1	16,700
TD	7.5	40	120	MT1	16,700
TD	8	40	120	MT1	16,700
TD	8.5	50	130	MT1	16,700
TD	9	50	130	MT1	16,700
TD	9.5	60	140	MT1	16,700
TD	10	60	140	MT1	16,700
TD	10.1	70	150	MT1	23,500
TD	10.2	70	150	MT1	23,500
TD	10.3	70	150	MT1	23,500
TD	10.4	70	150	MT1	23,500
TD	10.5	70	150	MT1	16,700
TD	10.6	70	150	MT1	23,500
TD	10.7	70	150	MT1	23,500
TD	10.8	70	150	MT1	23,500
TD	10.9	70	150	MT1	23,500
TD	11	70	150	MT1	16,700
TD	11.1	70	150	MT1	24,100
TD	11.2	70	150	MT1	24,100
TD	11.3	70	150	MT1	24,100
TD	11.4	70	150	MT1	24,100
TD	11.5	70	150	MT1	17,600
TD	11.6	70	150	MT1	24,100
TD	11.7	70	150	MT1	24,100
TD	11.8	70	150	MT1	24,100
TD	11.9	70	150	MT1	24,100
TD	12	70	150	MT1	17,600
TD	12.1	80	160	MT1	26,600
TD	12.2	80	160	MT1	26,600
TD	12.3	80	160	MT1	26,600
TD	12.4	80	160	MT1	26,600
TD	12.5	80	160	MT1	19,400
TD	12.6	80	160	MT1	26,600
TD	12.7	80	160	MT1	26,600
TD	12.8	80	160	MT1	26,600
TD	12.9	80	160	MT1	26,600
TD	13	80	160	MT1	19,400
TD	13.1	80	160	MT1	27,100
TD	13.2	80	160	MT1	27,100
TD	13.3	80	160	MT1	27,100
TD	13.4	80	160	MT1	27,100
TD	13.5	80	160	MT1	20,400
TD	13.6	80	160	MT1	27,100
TD	13.7	80	160	MT1	27,100

型番	刃径 (D)	溝長 (ℓ)	全長 (L)	シャンク	標準価格
TD	13.8	80	160	MT1	27,100
TD	13.9	80	160	MT1	27,100
TD	14	80	160	MT1	20,400
TD	14.1	100	200	MT2	27,700
TD	14.2	100	200	MT2	27,700
TD	14.3	100	200	MT2	27,700
TD	14.4	100	200	MT2	27,700
TD	14.5	100	200	MT2	21,700
TD	14.6	100	200	MT2	27,700
TD	14.7	100	200	MT2	27,700
TD	14.8	100	200	MT2	27,700
TD	14.9	100	200	MT2	27,700
TD	15	100	200	MT2	21,700
TD	15.1	100	200	MT2	28,200
TD	15.2	100	200	MT2	28,200
TD	15.3	100	200	MT2	28,200
TD	15.4	100	200	MT2	28,200
TD	15.5	100	200	MT2	23,000
TD	15.6	100	200	MT2	28,200
TD	15.7	100	200	MT2	28,200
TD	15.8	100	200	MT2	28,200
TD	15.9	100	200	MT2	28,200
TD	16	100	200	MT2	23,000
TD	16.1	100	200	MT2	31,900
TD	16.2	100	200	MT2	31,900
TD	16.3	100	200	MT2	31,900
TD	16.4	100	200	MT2	31,900
TD	16.5	100	200	MT2	24,100
TD	16.6	100	200	MT2	31,900
TD	16.7	100	200	MT2	31,900
TD	16.8	100	200	MT2	31,900
TD	16.9	100	200	MT2	31,900
TD	17	100	200	MT2	24,100
TD	17.1	100	200	MT2	33,100
TD	17.2	100	200	MT2	33,100
TD	17.3	100	200	MT2	33,100
TD	17.4	100	200	MT2	33,100
TD	17.5	100	200	MT2	25,200
TD	17.6	100	200	MT2	33,100
TD	17.7	100	200	MT2	33,100
TD	17.8	100	200	MT2	33,100
TD	17.9	100	200	MT2	33,100
TD	18	100	200	MT2	25,200
TD	18.1	110	210	MT2	34,700
TD	18.2	110	210	MT2	34,700
TD	18.3	110	210	MT2	34,700

(TD)  
超硬付刃テーパシャンクドリル  
Taper Shank Drills, G-2 Carbide Tipped

SINCE 1935  
F.K.D.®

材質=G2 (ロー付タイプ)  
リード角=右戻れ20°

刃径公差  
D ≤ 18 0~-0.030  
18 < D ≤ 29 0~-0.033  
29 < D ≤ 60 0~-0.039

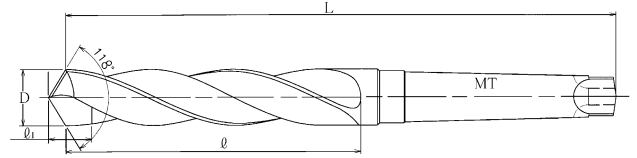

●注用例=型番、刃径、数量 「TD 18.4」

型番	刃径 (D)	溝長 (l)	全長 (L)	シャンク	標準価格
TD	18.4	110	210	MT2	34,700
TD	18.5	110	210	MT2	27,500
TD	18.6	110	210	MT2	34,700
TD	18.7	110	210	MT2	34,700
TD	18.8	110	210	MT2	34,700
TD	18.9	110	210	MT2	34,700
TD	19	110	210	MT2	27,500
TD	19.1	110	210	MT2	39,100
TD	19.2	110	210	MT2	39,100
TD	19.3	110	210	MT2	39,100
TD	19.4	110	210	MT2	39,100
TD	19.5	110	210	MT2	28,900
TD	19.6	110	210	MT2	39,100
TD	19.7	110	210	MT2	39,100
TD	19.8	110	210	MT2	39,100
TD	19.9	110	210	MT2	39,100
TD	20	110	210	MT2	28,900
TD	20.1	110	210	MT2	41,100
TD	20.2	110	210	MT2	41,100
TD	20.3	110	210	MT2	41,100
TD	20.4	110	210	MT2	41,100
TD	20.5	110	210	MT2	31,200
TD	20.6	110	210	MT2	41,100
TD	20.7	110	210	MT2	41,100
TD	20.8	110	210	MT2	41,100
TD	20.9	110	210	MT2	41,100
TD	21	110	210	MT2	31,200
TD	21.1	120	220	MT2	43,200
TD	21.2	120	220	MT2	43,200
TD	21.3	120	220	MT2	43,200
TD	21.4	120	220	MT2	43,200
TD	21.5	120	220	MT2	32,300
TD	21.6	120	220	MT2	43,200
TD	21.7	120	220	MT2	43,200
TD	21.8	120	220	MT2	43,200
TD	21.9	120	220	MT2	43,200
TD	22	120	220	MT2	32,300
TD	22.1	120	220	MT2	48,200
TD	22.2	120	220	MT2	48,200
TD	22.3	120	220	MT2	48,200
TD	22.4	120	220	MT2	48,200
TD	22.5	120	220	MT2	34,700
TD	22.6	120	220	MT2	48,200
TD	22.7	120	220	MT2	48,200
TD	22.8	120	220	MT2	48,200
TD	22.9	120	220	MT2	48,200

型番	刃径 (D)	溝長 (l)	全長 (L)	シャンク	標準価格
TD	23	120	220	MT2	34,700
TD	23.1	130	250	MT3	48,200
TD	23.2	130	250	MT3	48,200
TD	23.3	130	250	MT3	48,200
TD	23.4	130	250	MT3	48,200
TD	23.5	130	250	MT3	37,100
TD	23.6	130	250	MT3	48,200
TD	23.7	130	250	MT3	48,200
TD	23.8	130	250	MT3	48,200
TD	23.9	130	250	MT3	48,200
TD	24	130	250	MT3	37,100
TD	24.1	140	260	MT3	50,900
TD	24.2	140	260	MT3	50,900
TD	24.3	140	260	MT3	50,900
TD	24.4	140	260	MT3	50,900
TD	24.5	140	260	MT3	37,100
TD	24.6	140	260	MT3	50,900
TD	24.7	140	260	MT3	50,900
TD	24.8	140	260	MT3	50,900
TD	24.9	140	260	MT3	50,900
TD	25	140	260	MT3	37,100
TD	25.1	140	260	MT3	53,000
TD	25.2	140	260	MT3	53,000
TD	25.3	140	260	MT3	53,000
TD	25.4	140	260	MT3	53,000
TD	25.5	140	260	MT3	38,500
TD	25.6	140	260	MT3	53,000
TD	25.7	140	260	MT3	53,000
TD	25.8	140	260	MT3	53,000
TD	25.9	140	260	MT3	53,000
TD	26	140	260	MT3	38,500
TD	26.1	140	260	MT3	55,600
TD	26.2	140	260	MT3	55,600
TD	26.3	140	260	MT3	55,600
TD	26.4	140	260	MT3	55,600
TD	26.5	140	260	MT3	39,600
TD	26.6	140	260	MT3	55,600
TD	26.7	140	260	MT3	55,600
TD	26.8	140	260	MT3	55,600
TD	26.9	140	260	MT3	55,600
TD	27	140	260	MT3	39,600
TD	27.1	140	260	MT3	58,300
TD	27.2	140	260	MT3	58,300
TD	27.3	140	260	MT3	58,300
TD	27.4	140	260	MT3	58,300
TD	27.5	140	260	MT3	43,200

(TD)  
超硬付刃テーパシャンクドリル  
Taper Shank Drills, G-2 Carbide Tipped

SINCE 1935  
F.K.D.®

材質=G2 (ロー付タイプ)  
リード角=右振り20°

刃径公差  
D ≤ 18 0~-0.030  
18 < D ≤ 29 0~-0.033  
29 < D ≤ 60 0~-0.039

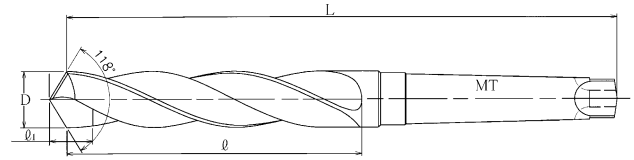
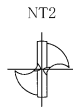

●注用例=型番、刃径、数量 「TD 27.6」

型番	刃径 (D)	溝長 (l)	全長 (L)	シャンク	標準価格
TD	27.6	140	260	MT3	58,300
TD	27.7	140	260	MT3	58,300
TD	27.8	140	260	MT3	58,300
TD	27.9	140	260	MT3	58,300
TD	28	140	260	MT3	43,200
TD	28.1	140	260	MT3	62,700
TD	28.2	140	260	MT3	62,700
TD	28.3	140	260	MT3	62,700
TD	28.4	140	260	MT3	62,700
TD	28.5	140	260	MT3	48,200
TD	28.6	140	260	MT3	62,700
TD	28.7	140	260	MT3	62,700
TD	28.8	140	260	MT3	62,700
TD	28.9	140	260	MT3	62,700
TD	29	140	260	MT3	48,200
TD	29.1	150	270	MT3	69,400
TD	29.2	150	270	MT3	69,400
TD	29.3	150	270	MT3	69,400
TD	29.4	150	270	MT3	69,400
TD	29.5	150	270	MT3	51,600
TD	29.6	150	270	MT3	69,400
TD	29.7	150	270	MT3	69,400
TD	29.8	150	270	MT3	69,400
TD	29.9	150	270	MT3	69,400
TD	30	150	270	MT3	51,600
TD	30.1	150	270	MT3	71,800
TD	30.2	150	270	MT3	71,800
TD	30.3	150	270	MT3	71,800
TD	30.4	150	270	MT3	71,800
TD	30.5	150	270	MT3	55,300
TD	30.6	150	270	MT3	71,800
TD	30.7	150	270	MT3	71,800
TD	30.8	150	270	MT3	71,800
TD	30.9	150	270	MT3	71,800
TD	31	150	270	MT3	55,300
TD	31.5	150	270	MT3	58,400
TD	32	150	270	MT3	58,400
TD	32.5	180	330	MT4	63,400

型番	刃径 (D)	溝長 (l)	全長 (L)	シャンク	標準価格
TD	33	180	330	MT4	63,400
TD	33.5	180	330	MT4	67,300
TD	34	180	330	MT4	67,300
TD	34.5	180	330	MT4	73,000
TD	35	180	330	MT4	73,000
TD	35.5	190	340	MT4	77,900
TD	36	190	340	MT4	77,900
TD	36.5	190	340	MT4	81,500
TD	37	190	340	MT4	81,500
TD	37.5	190	340	MT4	84,300
TD	38	190	340	MT4	84,300
TD	38.5	190	340	MT4	88,800
TD	39	190	340	MT4	88,800
TD	39.5	190	340	MT4	97,000
TD	40	190	340	MT4	97,000
TD	40.5	200	350	MT4	110,300
TD	41	200	350	MT4	110,300
TD	41.5	200	350	MT4	113,700
TD	42	200	350	MT4	113,700
TD	42.5	200	350	MT4	123,400
TD	43	200	350	MT4	123,400
TD	43.5	200	350	MT4	127,300
TD	44	200	350	MT4	127,300
TD	44.5	200	350	MT4	130,600
TD	45	200	350	MT4	130,600
TD	45.5	210	360	MT4	136,800
TD	46	210	360	MT4	136,800
TD	46.5	210	360	MT4	141,500
TD	47	210	360	MT4	141,500
TD	47.5	210	360	MT4	152,100
TD	48	210	360	MT4	152,100
TD	48.5	210	360	MT4	163,200
TD	49	210	360	MT4	163,200
TD	49.5	210	360	MT4	165,600
TD	50	210	360	MT4	165,600
TD	55	210	399	MT5	213,300
TD	60	222	412	MT5	292,900



# (SSD) 超硬先ムクストレートシャンクドリル



Straight Shank Drills, G-2 Top Solid Carbide

材質=G2 (ロー付タイプ)  
リード角=右振れ28° ~30°  
シンニング=×

刃径公差  
D ≤ 10.5 0~-0.022  
10.5 < D ≤ 18.5 0~-0.027  
18.5 < D ≤ 25.0 0~-0.033

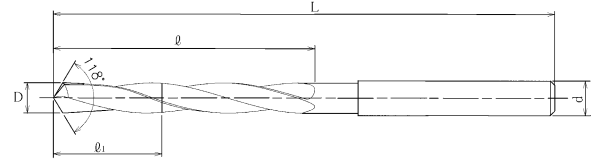

●注文例=型番、刃径、数量「SSD 6」

型番	刃径 (D)	溝長 (Ø)	チップ長	全長 (L)	シャンク径 (d)	標準価格
SSD 6	6	60	25	115	8	41,500
SSD 6.5	6.5	60	25	115	8	41,500
SSD 7	7	60	25	115	8	41,500
SSD 7.5	7.5	60	25	115	8	41,500
SSD 8	8	65	27	130	8	41,500
SSD 8.5	8.5	65	27	130	10	41,500
SSD 9	9	65	27	130	10	43,700
SSD 9.5	9.5	65	27	130	10	45,300
SSD 10	10	70	30	140	10	45,900
SSD 10.5	10.5	70	30	140	10	48,200
SSD 11	11	70	30	140	12	50,900
SSD 11.5	11.5	70	30	140	12	52,300
SSD 12	12	75	32	150	12	53,100
SSD 12.5	12.5	75	32	150	12	55,100
SSD 13	13	75	32	150	12	56,500
SSD 13.5	13.5	75	32	150	12	59,700
SSD 14	14	75	32	150	12	62,900
SSD 14.5	14.5	80	34	160	16	66,000
SSD 15	15	80	34	160	16	70,700
SSD 15.5	15.5	80	34	160	16	71,900

型番	刃径 (D)	溝長 (Ø)	チップ長	全長 (L)	シャンク径 (d)	標準価格
SSD 16	16	80	34	160	16	74,300
SSD 16.5	16.5	100	35	180	16	77,900
SSD 17	17	100	35	180	16	81,300
SSD 17.5	17.5	100	35	180	16	84,300
SSD 18	18	100	35	180	20	86,400
SSD 18.5	18.5	120	37	200	20	91,100
SSD 19	19	120	37	200	20	94,300
SSD 19.5	19.5	120	37	200	20	97,100
SSD 20	20	120	37	200	20	99,300
SSD 20.5	20.5	120	37	200	20	102,000
SSD 21	21	120	37	200	20	104,100
SSD 21.5	21.5	140	39	220	20	107,800
SSD 22	22	140	39	220	20	110,400
SSD 22.5	22.5	140	39	220	25	113,200
SSD 23	23	140	39	220	25	115,600
SSD 23.5	23.5	160	44	240	25	121,100
SSD 24	24	160	44	240	25	124,000
SSD 24.5	24.5	160	44	240	25	127,800
SSD 25	25	160	44	240	25	129,100

# (STD)

## 在庫なくなり次第 廃番 超硬先ムクテーパースhanクドリル

Taper Shank Drills, G-2 Top Solid Carbide

材質=G2 (ロー付タイプ)  
リード角=右振れ28° ~30°  
シンニング=×

刃径公差  
D ≤ 10.5 0~-0.022  
10.5 < D ≤ 18.5 0~-0.027  
18.5 < D ≤ 25.0 0~-0.033

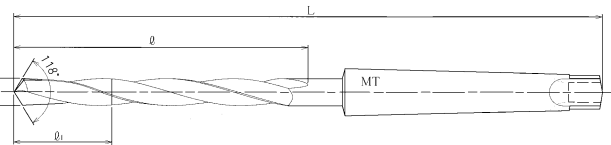

●注文例=型番、刃径、数量「STD 6」

型番	刃径 (D)	溝長 (Ø)	チップ長	全長 (L)	シャンク	標準価格
STD 6	6	75	25	150	MT1	45,300
STD 6.5	6.5	75	25	150	MT1	45,300
STD 7	7	75	25	150	MT1	45,300
STD 7.5	7.5	75	25	150	MT1	45,300
STD 8	8	85	27	170	MT1	45,300
STD 8.5	8.5	85	27	170	MT1	45,300
STD 9	9	85	27	170	MT1	47,600
STD 9.5	9.5	85	27	170	MT1	49,500
STD 10	10	100	30	185	MT1	50,100
STD 10.5	10.5	100	30	185	MT1	52,600
STD 11	11	100	30	185	MT1	55,700
STD 11.5	11.5	100	30	185	MT1	57,000
STD 12	12	115	32	200	MT1	58,000
STD 12.5	12.5	115	32	200	MT1	60,100
STD 13	13	115	32	200	MT1	61,600
STD 13.5	13.5	115	32	200	MT1	65,100
STD 14	14	115	32	200	MT1	68,500
STD 14.5	14.5	125	34	225	MT2	72,000
STD 15	15	125	34	225	MT2	77,200
STD 15.5	15.5	125	34	225	MT2	78,500

型番	刃径 (D)	溝長 (Ø)	チップ長	全長 (L)	シャンク	標準価格
STD 16	16	125	34	225	MT2	81,000
STD 16.5	16.5	145	35	240	MT2	85,000
STD 17	17	145	35	240	MT2	88,800
STD 17.5	17.5	145	35	240	MT2	91,900
STD 18	18	145	35	240	MT2	94,300
STD 18.5	18.5	150	37	250	MT2	99,400
STD 19	19	150	37	250	MT2	102,800
STD 19.5	19.5	150	37	250	MT2	106,000
STD 20	20	150	37	250	MT2	108,300
STD 20.5	20.5	150	37	250	MT2	111,200
STD 21	21	150	37	250	MT2	113,600
STD 21.5	21.5	160	39	265	MT2	117,500
STD 22	22	160	39	265	MT2	120,500
STD 22.5	22.5	160	39	265	MT2	123,500
STD 23	23	160	39	265	MT2	126,200
STD 23.5	23.5	165	44	285	MT3	132,000
STD 24	24	165	44	285	MT3	135,200
STD 24.5	24.5	165	44	285	MT3	139,400
STD 25	25	165	44	285	MT3	140,900

(SLD)  
超硬付刃スリムシャンクドリル  
Collet Use Carbide Tipped Drills

SINCE 1935  
F.K.D.®

材質=G2 (ロー付タイプ)  
リード角=右振れ20°  
刃径公差=0~-0.03

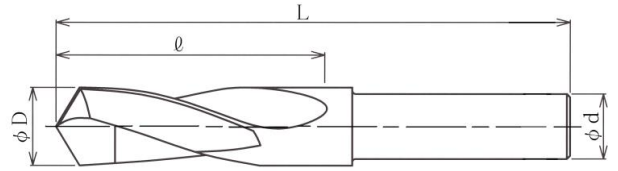

●注文例=型番、刃径、数量 「SLD 14」

型番	刃径 (D)	溝長 (l)	全長 (L)	シャンク径 (d)	標準価格
SLD	14	70	150	12	16,800
SLD	14.5	70	150	12	18,000
SLD	15	70	150	12	18,000
SLD	15.5	70	150	12	18,700
SLD	16	70	150	12	18,700
SLD	16.5	70	150	12	20,100
SLD	17	70	150	16	20,100
SLD	17.5	70	150	16	21,000
SLD	18	70	150	16	21,000
SLD	18.5	70	150	16	23,000
SLD	19	70	150	16	23,000
SLD	19.5	70	150	16	24,200

型番	刃径 (D)	溝長 (l)	全長 (L)	シャンク径 (d)	標準価格
SLD	20	70	150	16	24,200
SLD	20.5	70	150	16	26,100
SLD	21	70	150	20	26,100
SLD	21.5	70	150	20	27,300
SLD	22	70	150	20	27,300
SLD	22.5	70	150	20	29,300
SLD	23	70	150	20	29,300
SLD	23.5	70	150	20	31,100
SLD	24	70	150	20	31,100
SLD	24.5	70	150	20	31,900
SLD	25	70	150	20	31,900
SLD	25.5	70	150	20	32,300
SLD	26	70	150	20	32,300

# (EMCR) EMCスーパードリル・レギュラー形

EMC Super Drills Regular

SINCE 1935  
F.K.D.®

材質=Co8% 粉末ハイス  
リード角=右戻れ30°

TiAlNコーティング

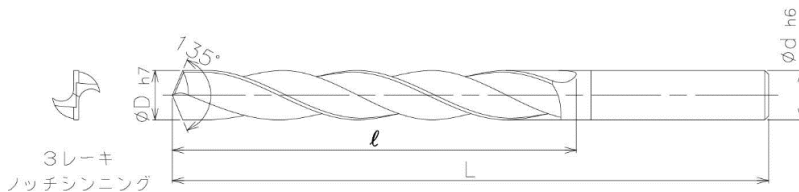

●注文例=型番、刃径、数量「EMCR 10」

型番	刃径 (D)	溝長 (l)	全長 (L)	シャンク径 (d)	標準価格
EMCR	2	24	56	3	1,900
EMCR	2.1	24	56	3	2,300
EMCR	2.2	25	56	3	2,300
EMCR	2.3	25	56	3	2,300
EMCR	2.4	30	61	3	2,300
EMCR	2.5	30	61	3	2,000
EMCR	2.6	30	61	3	2,300
EMCR	2.7	33	64	3	2,300
EMCR	2.8	33	64	3	2,300
EMCR	2.9	33	64	3	2,300
EMCR	3	33	64	3	2,000
EMCR	3.1	36	68	4	2,600
EMCR	3.2	36	68	4	2,600
EMCR	3.3	36	68	4	2,600
EMCR	3.4	39	71	4	2,600
EMCR	3.5	39	71	4	2,500
EMCR	3.6	39	71	4	2,900
EMCR	3.7	39	71	4	2,900
EMCR	3.8	43	75	4	2,900
EMCR	3.9	43	75	4	2,900
EMCR	4	43	75	4	2,800
EMCR	4.1	43	85	6	3,300
EMCR	4.2	43	85	6	3,300
EMCR	4.3	47	89	6	3,300
EMCR	4.4	47	89	6	3,300
EMCR	4.5	47	89	6	3,200
EMCR	4.6	47	89	6	3,600
EMCR	4.7	47	89	6	3,600
EMCR	4.8	52	94	6	3,600
EMCR	4.9	52	94	6	3,600
EMCR	5	52	94	6	4,200
EMCR	5.1	52	94	6	4,300
EMCR	5.2	52	94	6	4,300
EMCR	5.3	52	94	6	4,300
EMCR	5.4	57	99	6	4,300
EMCR	5.5	57	99	6	4,300
EMCR	5.6	57	99	6	4,500
EMCR	5.7	57	99	6	4,500
EMCR	5.8	57	99	6	4,500
EMCR	5.9	57	99	6	4,500
EMCR	6	57	99	6	4,400
EMCR	6.1	63	107	8	5,000
EMCR	6.2	63	107	8	5,000
EMCR	6.3	63	107	8	5,000
EMCR	6.4	63	107	8	5,000
EMCR	6.5	63	107	8	4,800
EMCR	6.6	63	107	8	5,400
EMCR	6.7	63	107	8	5,400
EMCR	6.8	69	113	8	5,400
EMCR	6.9	69	113	8	5,400
EMCR	7	69	113	8	5,200
EMCR	7.1	69	113	8	5,800
EMCR	7.2	69	113	8	5,800
EMCR	7.3	69	113	8	5,800
EMCR	7.4	69	113	8	5,800
EMCR	7.5	69	113	8	5,400
EMCR	7.6	75	119	8	6,100
EMCR	7.7	75	119	8	6,100
EMCR	7.8	75	119	8	6,100
EMCR	7.9	75	119	8	6,100
EMCR	8	75	119	8	5,700
EMCR	8.1	75	125	10	6,600
EMCR	8.2	75	125	10	6,600

型番	刃径 (D)	溝長 (l)	全長 (L)	シャンク径 (d)	標準価格
EMCR	8.3	75	125	10	6,600
EMCR	8.4	75	125	10	6,600
EMCR	8.5	75	125	10	6,600
EMCR	8.6	81	131	10	7,000
EMCR	8.7	81	131	10	7,000
EMCR	8.8	81	131	10	7,000
EMCR	8.9	81	131	10	7,000
EMCR	9	81	131	10	6,800
EMCR	9.1	81	131	10	7,500
EMCR	9.2	81	131	10	7,500
EMCR	9.3	81	131	10	7,500
EMCR	9.4	81	131	10	7,500
EMCR	9.5	81	131	10	7,500
EMCR	9.6	87	137	10	8,300
EMCR	9.7	87	137	10	8,300
EMCR	9.8	87	137	10	8,300
EMCR	9.9	87	137	10	8,300
EMCR	10	87	137	10	7,900
EMCR	10.1	87	144	12	9,000
EMCR	10.2	87	144	12	9,000
EMCR	10.3	87	144	12	9,000
EMCR	10.4	87	144	12	9,000
EMCR	10.5	87	144	12	8,900
EMCR	10.6	87	144	12	9,900
EMCR	10.7	94	151	12	9,900
EMCR	10.8	94	151	12	9,900
EMCR	10.9	94	151	12	9,900
EMCR	11	94	151	12	9,500
EMCR	11.1	94	151	12	11,100
EMCR	11.2	94	151	12	11,100
EMCR	11.3	94	151	12	11,100
EMCR	11.4	94	151	12	11,100
EMCR	11.5	94	151	12	11,000
EMCR	11.6	94	151	12	12,000
EMCR	11.7	94	151	12	12,000
EMCR	11.8	94	151	12	12,000
EMCR	11.9	94	151	12	12,000
EMCR	12	94	151	12	11,700
EMCR	12.1	101	158	12	13,200
EMCR	12.2	101	158	12	13,200
EMCR	12.3	101	158	12	13,200
EMCR	12.4	101	158	12	13,200
EMCR	12.5	101	158	12	13,000
EMCR	12.6	101	158	12	14,000
EMCR	12.7	101	158	12	14,000
EMCR	12.8	101	158	12	14,000
EMCR	12.9	101	158	12	14,000
EMCR	13	101	158	12	13,400
EMCR	13.5	105	165	16	21,000
EMCR	14	105	165	16	21,000
EMCR	14.5	110	170	16	23,300
EMCR	15	110	170	16	24,200
EMCR	15.5	115	175	16	26,400
EMCR	16	115	175	16	26,400
EMCR	16.5	115	180	20	27,300
EMCR	17	115	180	20	27,300
EMCR	17.5	120	185	20	30,000
EMCR	18	120	185	20	30,000
EMCR	18.5	125	190	20	32,900
EMCR	19	125	190	20	34,000
EMCR	19.5	125	190	20	35,400
EMCR	20	125	190	20	35,400

※ 特定代理店のみの扱いです。

# (EMCS) EMCSスーパードリル・スタブ形

SINCE 1935  
F.K.D.®

材質=Co8% 粉末ハイス  
リード角=右戻れ30°

TiAlNコーティング

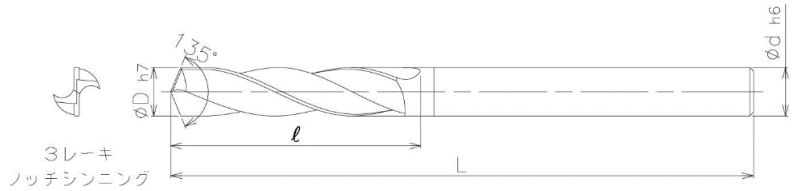

●注文例=型番、刃径、数量「EMCS 10」

型番	刃径 (D)	溝長 (l)	全長 (L)	シャンク径 (d)	標準価格
EMCS	2	12	44	3	1,800
EMCS	2.1	12	44	3	2,000
EMCS	2.2	13	45	3	2,000
EMCS	2.3	13	45	3	2,000
EMCS	2.4	14	46	3	2,000
EMCS	2.5	14	46	3	1,900
EMCS	2.6	14	46	3	2,000
EMCS	2.7	16	48	3	2,000
EMCS	2.8	16	48	3	2,000
EMCS	2.9	16	48	3	2,000
EMCS	3	16	48	3	1,900
EMCS	3.1	18	50	4	2,400
EMCS	3.2	18	50	4	2,400
EMCS	3.3	18	50	4	2,400
EMCS	3.4	20	52	4	2,400
EMCS	3.5	20	52	4	2,300
EMCS	3.6	20	52	4	2,500
EMCS	3.7	20	52	4	2,500
EMCS	3.8	22	54	4	2,500
EMCS	3.9	22	54	4	2,500
EMCS	4	22	54	4	2,500
EMCS	4.1	22	66	6	2,900
EMCS	4.2	22	66	6	2,900
EMCS	4.3	24	68	6	2,900
EMCS	4.4	24	68	6	2,900
EMCS	4.5	24	68	6	2,800
EMCS	4.6	24	68	6	3,300
EMCS	4.7	24	68	6	3,300
EMCS	4.8	26	70	6	3,300
EMCS	4.9	26	70	6	3,300
EMCS	5	26	70	6	3,900
EMCS	5.1	26	70	6	4,000
EMCS	5.2	26	70	6	4,000
EMCS	5.3	26	70	6	4,000
EMCS	5.4	28	72	6	4,000
EMCS	5.5	28	72	6	4,000
EMCS	5.6	28	72	6	4,200
EMCS	5.7	28	72	6	4,200
EMCS	5.8	28	72	6	4,200
EMCS	5.9	28	72	6	4,200
EMCS	6	28	72	6	4,100
EMCS	6.1	31	75	8	4,300
EMCS	6.2	31	75	8	4,300
EMCS	6.3	31	75	8	4,300
EMCS	6.4	31	75	8	4,300
EMCS	6.5	31	75	8	4,200
EMCS	6.6	31	75	8	4,700
EMCS	6.7	31	75	8	4,700
EMCS	6.8	34	78	8	4,700
EMCS	6.9	34	78	8	4,700
EMCS	7	34	78	8	4,500
EMCS	7.1	34	78	8	5,100
EMCS	7.2	34	78	8	5,100
EMCS	7.3	34	78	8	5,100
EMCS	7.4	34	78	8	5,100
EMCS	7.5	34	78	8	4,800
EMCS	7.6	37	81	8	5,400
EMCS	7.7	37	81	8	5,400
EMCS	7.8	37	81	8	5,400
EMCS	7.9	37	81	8	5,400
EMCS	8	37	81	8	5,100
EMCS	8.1	37	87	10	5,900
EMCS	8.2	37	87	10	5,900

型番	刃径 (D)	溝長 (l)	全長 (L)	シャンク径 (d)	標準価格
EMCS	8.3	37	87	10	5,900
EMCS	8.4	37	87	10	5,900
EMCS	8.5	37	87	10	5,700
EMCS	8.6	40	90	10	6,500
EMCS	8.7	40	90	10	6,500
EMCS	8.8	40	90	10	6,500
EMCS	8.9	40	90	10	6,500
EMCS	9	40	90	10	5,900
EMCS	9.1	40	90	10	6,900
EMCS	9.2	40	90	10	6,900
EMCS	9.3	40	90	10	6,900
EMCS	9.4	40	90	10	6,900
EMCS	9.5	40	90	10	6,500
EMCS	9.6	43	93	10	7,500
EMCS	9.7	43	93	10	7,500
EMCS	9.8	43	93	10	7,500
EMCS	9.9	43	93	10	7,500
EMCS	10	43	93	10	6,700
EMCS	10.1	43	100	12	7,900
EMCS	10.2	43	100	12	7,900
EMCS	10.3	43	100	12	7,900
EMCS	10.4	43	100	12	7,900
EMCS	10.5	43	100	12	7,400
EMCS	10.6	43	100	12	8,700
EMCS	10.7	47	104	12	8,700
EMCS	10.8	47	104	12	8,700
EMCS	10.9	47	104	12	8,700
EMCS	11	47	104	12	7,800
EMCS	11.1	47	104	12	10,000
EMCS	11.2	47	104	12	10,000
EMCS	11.3	47	104	12	10,000
EMCS	11.4	47	104	12	10,000
EMCS	11.5	47	104	12	9,100
EMCS	11.6	47	104	12	10,800
EMCS	11.7	47	104	12	10,800
EMCS	11.8	47	104	12	10,800
EMCS	11.9	47	104	12	10,800
EMCS	12	51	108	12	9,600
EMCS	12.1	51	108	12	11,700
EMCS	12.2	51	108	12	11,700
EMCS	12.3	51	108	12	11,700
EMCS	12.4	51	108	12	11,700
EMCS	12.5	51	108	12	10,800
EMCS	12.6	51	108	12	12,400
EMCS	12.7	51	108	12	12,400
EMCS	12.8	51	108	12	12,400
EMCS	12.9	51	108	12	12,400
EMCS	13	51	108	12	11,100
EMCS	13.5	54	114	16	16,700
EMCS	14	54	114	16	16,700
EMCS	14.5	56	116	16	18,500
EMCS	15	56	116	16	19,500
EMCS	15.5	58	118	16	21,000
EMCS	16	58	118	16	21,000
EMCS	16.5	60	125	20	21,900
EMCS	17	60	125	20	21,900
EMCS	17.5	62	127	20	23,800
EMCS	18	62	127	20	23,800
EMCS	18.5	64	129	20	26,400
EMCS	19	64	129	20	27,100
EMCS	19.5	66	131	20	28,500
EMCS	20	66	131	20	28,500

※ 特定代理店のみの扱いです。